

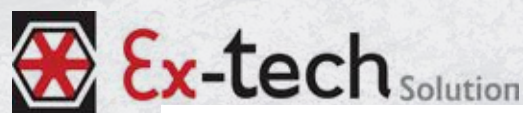

Equipment and Solutions



Vector InfoTech

www.vectorinfotech.com
sales@vectorinfotech.com



Subject to errors or changes
Editing completed January 2016



Ex-tech Group is located at Forus in Stavanger, Norway, one of the world's top Centers of Excellence within knowledge and technology related to the Oil and Gas industry.

Our main office has all oil majors and NOC is located in close proximity.

Our engineers, with experience from the oil and gas industry, are used to the strictest demands and specifications.

The group consist of three fully owned subsidiaries, each with different competence and skills, enabling the group to be a complete and preferred supplier and partner in the **Ex** market.



Ex-tech Solution is our French subsidiary.

The company (formerly Schneider Electric) has for more than 40 years been manufacturing a wide range of Ex components, equipment and solutions for the Oil & Gas onshore market.

From small Ex switches and lamps to large Ex d enclosures for complex systems. A close and fruitful collaboration with French industry and local sub-suppliers.



Ex-tech Signalling is our second subsidiary in France.

The company represents the groups center of excellence related to audio and visual signalling equipment, used mainly for signalling in combination with Fire & Gas as well as Telecom systems.



Ex-tech System is our subsidiary in Norway, representing the center of Excellence within systems & solutions for the Oil & Gas offshore market.

The company is offering a wide range of components and enclosures to complex Ex systems, including a close collaboration with sub-suppliers.

In addition the company has a long tradition and experience in converting industrial electrical and combustion machines to be used in explosive atmospheres.

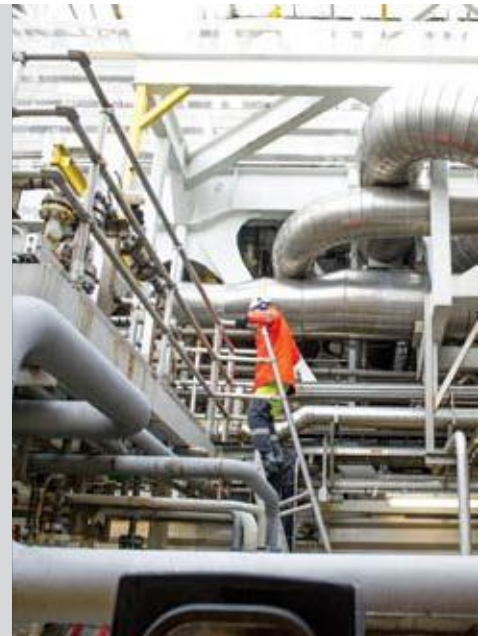

Control stations and signalling units

The XAW control stations are equipped with our extensive range of our wide control and signalling units HarmAtex. They combine the functions start and stop for motors, as fans, pumps, ... and they can be provided with measuring instruments for current control, voltage or other physical quantities.



Motor starters, motor switches

The 3 poles motor starters in protection modes Ex d IIB or Ex IIC meet all your needs for from 0.37 up to 37 kW.

The wide range of enclosures combined with a wide range of contractors, thermal relays, allows real flexibility to adapt.

The disconnecter switches in increased safety Ex e, easy to implement, provides range of switching capacity from 20 A to 63 A and operating temperatures from -50 °C to +60 °C.

Systems and panels for control and monitoring

The flameproof enclosures are designed for control, monitoring, automation, distribution board, motor starters or any other application.

Made in carbon steel, aluminium or stainless steel for gas groups IIB or IIB+H2 or IIC with a wide range of sizes: up to 1590 x 940 mm for a dissipated power of 2000 W, they are suitable for the design of complex systems.



Junction boxes

The junction boxes are provided in flameproof protection mode Ex d IIB or IIC or in increased safety Ex e IIC.

Made in GRP, aluminium, cast iron or stainless steel, they are suitable for environments with the presence of chemical agents, corrosion resistant, operating temperatures from -50 °C to +60 °C/+75 °C.

They are equipped with terminals or push buttons, switches, pilot lights and measuring instruments.

Luminaires

A range of lighting fixtures 100% encapsulated, maintenance-free requiring only a visual inspection, designed with a body seawater resistant in anodized aluminium (in accordance with NORSOK 121), very easy and quick to install.

They are condensation free and have a tempered glass with very high impact resistance IK 20 and warranted 10 years.



Limit switches, photocells, pressure switches

The range of limit switches and pressure switches (from 0.1 to 500 bars) to control in a safe way movements, fluids in hazardous areas. The range is one of the most extensive in the market.

With a footprint of only 30 mm in diameter, our photocells are pre-wired and certified ATEX Ex d.

Audible and visual signalling devices

A full range of Sounders, Beacons, Call-point, or Junction box, well adapted to your applications.

Each range is available with housing in stainless steel or GRP, full range of voltage supply exist.



Content

Ex regulations	6
Atex and IECEx regulations	
IP rating	
IK rating	
Control stations	21
Increased safety - Polyester, aluminium, stainless steel	
Flameproof - Aluminium - Gas group IIB and IIC	
Increased safety - Pendant stations	
Increased safety - Fire control station	
Control and signalling units HarmAtex	39
Push buttons, emergency stops, selector switches, pilot lights, illuminated	
Foot switches	
Pull-wire switches	
Motor starters - Motor switches	59
Flameproof Motor starters - Gas group IIB and IIC	
Increased safety Motor switches	
Junction boxes	67
Increased safety - Polyester, aluminium, stainless steel	
Flameproof - Iron or aluminium - Gas group IIB or IIC	
Flameproof - Aluminium - Large boxes - Gas group IIB	
Flameproof enclosures gas group IIB + H₂ or IIC, Ex e cabinets	81
Heavy series IIB + H ₂ - Carbon steel or stainless steel	
Heavy series IIB + H ₂ with Ex e enclosure - Carbon steel or stainless steel	
Aluminium or stainless steel IIB + H ₂ series	
Aluminium or stainless steel IIB + H ₂ with Ex e enclosure	
Carbon steel or stainless steel - Group IIC series	
Carbon steel or stainless steel - Group IIC series with Ex E enclosure	
Increased safety control cabinets - Painted steel or stainless steel	
Lighting	103
Durable lighting fixtures	
Sensors - Photocells - Pressure switches	109
Limit switches - Flameproof - Group IIC	
Limit switches - Increased safety	
Photocells - Flameproof - Group IIC	
Pressures switches - Flameproof - - Group IIC	
Cable glands	129
Cable glands in polyimide or brass nickel plated	
Ex-tech Signalling products	135
Beacons / light	
Sounders / horns	
Sounders and beacons	
Combined products	
Status lights	
Manual call points	
Push buttons	
Junction boxes	
Accessories and spare parts	

1. General information

An explosive atmosphere is a result of the mixture with air, under atmospheric conditions and flammable substances in the form of gas, vapours, dusts, fibers which, once ignited, allow the combustion process to spread and permits self-sustaining propagation.

Explosive atmosphere can be encountered, as result of technical processing sequences, in several industries such as: petrochemical, mills and silos generating combustible dust, in mining by the methane gas and coal dust. Further areas can develop explosive atmosphere like: paint industry, recycling industry, production of biogas.

2. Explosion

The conditions for creating an explosion are: air, flammable substances and ignition source.

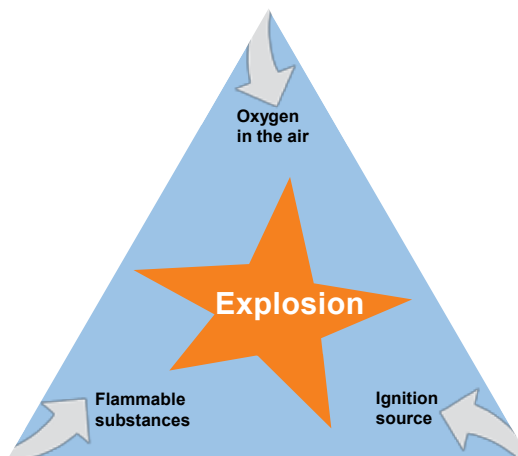

There are two main principles to avoid an explosion: primary and secondary precautions.

The primary explosion protections are the measures to take to prevent the creation of an explosive atmosphere:

- Measures using natural or forced ventilation to limit the explosive concentration
- Measures avoiding flammable substances
- Measures using inert gas in the atmosphere (e.g. Nitrogen)

The secondary explosion protections are the measures to prevent the ignition of an explosive atmosphere.

Type of Ignition Sources

- Hot surfaces
- Flames and hot gases
- Mechanically produced sparks
- Electrical equipment
- Transient currents
- Static electricity
- Lightning strikes
- Electromagnetic waves
- Optical radiation
- Ultrasound
- Chemical reactions
- People (indirectly)

The techniques of equipment protection for use in explosive atmospheres are just a matter of controlling (eliminating) possible ignition sources (secondary explosion protection)

3. Explosive atmosphere

Where do we find explosive atmospheres?

- Metal surface grinding, especially aluminium dust and particles
- Oil refineries, rigs and processing plants
- Gas pipelines and distribution centres
- Printing industries, paper and textiles
- Aircraft refuelling and hangars
- Chemical processing plants
- Grain handling and storage
- Sewage treatment plants
- Surface coating industries
- Underground coal mines
- Woodworking areas
- Sugar refineries
- Vessels/ships
- Power plants

Where a potential explosive atmosphere can occur, certain safety levels need to be taken into account regarding the possible danger of an explosion in this area. The areas therefore need to be divided into zones according to presence of the flammable substances.

Zone 0	Zone 1	Zone 2
A place in which an explosive atmosphere consisting of a mixture with air of flammable substances in the form of gas, vapour or mist is present continuously or for long periods or frequently.	A place in which an explosive atmosphere consisting of a mixture with air or flammable substances in the form of gas, vapour or mist is likely to occur in normal operation occasionally.	A place in which an explosive atmosphere consisting of a mixture with air of flammable substances in the form of gas, vapour or mist is not likely to occur in normal operation, but - if it does occur - will persist for a short period only.
Explosive atmosphere for more than 1000 h/yr.	Explosive atmosphere for more than 10, but less than 1000 h/yr.	Explosive atmosphere for less than 10 h/yr
Zone 20	Zone 21	Zone 22
A place in which an explosive atmosphere in the form of cloud of combustible dust in air is present continuously, or for long periods or frequently.	A place in which an explosive atmosphere in the form of a cloud of combustible dust in air is likely to occur in normal operation occasionally.	A place in which an explosive atmosphere in the form of a cloud of combustible dust in air is not likely to occur in normal operation, but - if it does occur - will persist for a short period only.

4. Criteria of flammable substances

Examples of the criteria for the mixture of flammable substances (gas) towards air in such a way that an explosion can occur are:

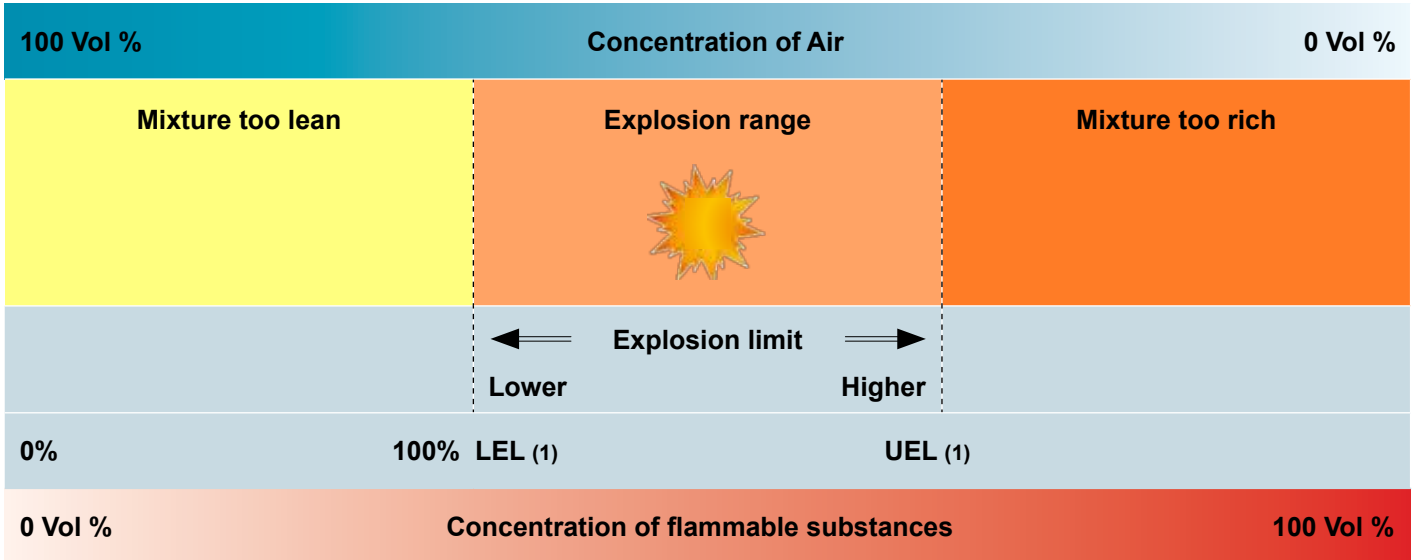

(1) LEL (**L**ower **E**xplosive **L**imit)
 UEL (**U**pper **E**xplosive **L**imit)

Typical concentration of gas/vapours in the air where an explosion can appear (% vol. of gas in air):

	LEL	Explosion	UEL
Methane	4.4%	→	16.5%
Propane	1.7%	→	10.6%
Butane	1.4%	→	9.3%

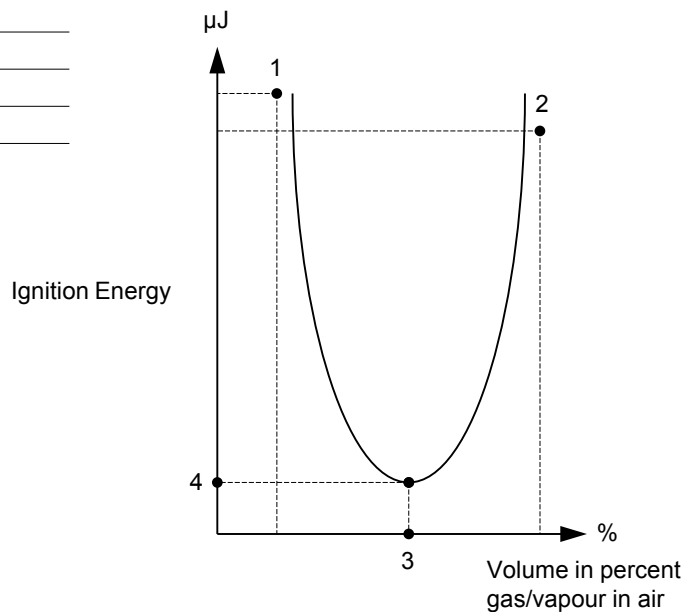

1. LEL (**L**ower **E**xplosion **L**imit)
2. UEL (**U**pper **E**xplosion **L**imit)
3. Optimum mixture
4. MIE (**M**inimum **I**gnition **E**nergy)

5. ATEX Directives

- Product Directive 1994/9/EC
- New product Directive 2014/34/EU
- User Directive 1999/92/EC

5.1 Equipment Directive 1994/9/EC

This directive has been mandatory in Europe from 01.07.2003, and covers the regulations concerning equipment and protective systems for use in potentially explosive atmospheres. This directive has four chapters which are subdivided into 16 articles. In each chapter it is made reference to the Annex I to XI, which include 7 modules.

For full info visit <http://ec.europa.eu/enterprise/atex/internationaldevelopment.htm>

Content of directive 94/9/EC		
Main part		
Chapter	Article	Heading
I	1 - 7	Scope of application, placed in service and free movement of goods
II	8 - 9	Conformity assessment procedures
III	10 - 11	CE marking of conformity
IV	12 - 16	Concluding provisions
Annexes		
I	Criteria determining the classification decision of equipment groups in categories	
II	Essential safety and health requirements for the design and construction of equipment and protective systems for use in potentially explosive atmospheres	
III	Module: EC-type examination	
IV	Module: Production Quality assurance	
V	Module: Product verification	
VI	Module: Conformity to type	
VII	Module: Product Quality assurance	
VIII	Module: Internal control of production	
IX	Module: Unit verification	
X	CE marking and contents of the EC declaration of conformity	
XI	Minimum criteria to be taken into account by member states for the notification of bodies	

5.2 Groups and categories

The directive 1994/9/EC is dividing the equipment into groups and categories.

- Equipment Group I apply for mining.
This group is subdivided into categories M1 & M2
- Equipment Group II applies for all others (surface) areas.
This group is subdivided into categories 1, 2 and 3

NOTE: Equipment group III for dust according to EN/IEC 60079-0

Group Mining Industries		Group Regular Industries (Gas and Dust areas)		
Category M1	Category M2	Category 1	Category 2	Category 3
Very high level of protection (safe with 2 faults)	High level of protection (safe with 1 fault)	Very high level of protection (safe with 2 faults)	High level of protection (safe with 1 fault)	Normal level of protection (safe during normal operation)
Must remain functional under specific explosive atmosphere concentrations	De-energized under specific explosive atmosphere			
Marking				
I MI	I M2	II 1 G (Gas) II 1 D (Dust)	II 2 G (Gas) II 2 D (Dust)	II 3G (Gas) II 3D (Dust)

Electrical equipment			
Aera Zone	Equipment Category	How to comply	Production requirements
2	3	The manufacturer must evaluate the equipment according to valid standard/Directives, and create a technical file and subsequently issuing an EC D.O.C (Declaration of Conformity)	The manufacturer needs to insure a production quality
1	2	EC-type examination certificate from Notified Body like: DNV, Nemko, INERIS	The manufacturer needs to have a production quality system and obtain a Production Quality
0	1	EC-type examination certificate from Notified Body like: DNV, Nemko, INERIS	

Non electrical equipment			
Aera Zone	Equipment Category	How to be in accordance with the ATEX directive	
2	3	To be verified by the manufacturer and submit a Technical File Manufacturer to issue EC D.O.C.	
1	2	To be verified by manufacturer and submit technical file to Notified Body (Nemko, DNV, INERIS e.g.) Manufacturer to issue EC D.O.C.	
0	1	To be certified by NB, EC-type examination certificate from Notified Body, DNV, Nemko, INERIS e.g.) Manufacturer to issue EC D.O.C.	

5.3 Marking

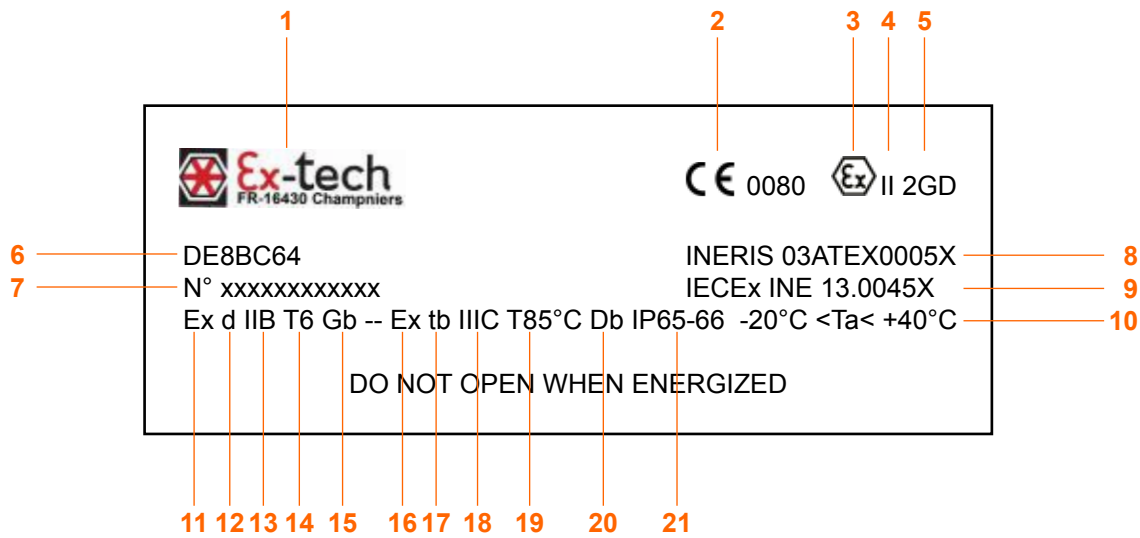

- 1 Manufacturer name
- 2 Conformity mark with identification number of the Notified Body
- 3 Ex mark
- 4 Equipment group II
- 5 Equipment category 2 - Gas/Vapours and Dust
- 6 Product code
- 7 Product serial number
- 8 Certificate number according to ATEX standards
- 9 Certificate number according to IECEx standards
- 10 Ambient temperature range

Marking for Gas/Vapours

- 11 Electrical apparatus to be installed in hazardous location
- 12 Type of protection: flameproof enclosure
- 13 Explosion gas group IIB
- 14 Temperature class T6
- 15 Equipment protection level Gb (high protection level) - Use in zone 1 and 2

Marking for Dust

- 16 Electrical apparatus to be installed in hazardous location
- 17 Type of protection: protection by enclosure
- 18 Explosion dust group IIIC (conductive types of dust)
- 19 Maximum surface temperature 85 °C
- 20 Equipment protection level Db (high protection level) - Use in zone 1 and 2
- 21 IP protection

Note:

The equipment also needs to be marked with the conventional protection mode (Ex...) according to EN/IEC 60079-0 (EN/IEC 61241-0 (60079-31 for dust atmospheres or 80079-36 for non-electrical).

The operating instructions manual of the manufacturer must clearly define the intended use of the equipment by the operator. The minimum requirements for the operating instruction are amongst others:

- Information about safety aspects
- Installation, putting into service, use
- Assembling and dismantling, maintenance (servicing and emergency repair)
- Adjustment

5.4 Manufacturer's Declaration of conformity

Equipment and protective systems can be placed on the market, only if marked with the CE mark and complete with operating instructions and the manufacturer's Declaration of Conformity. The CE conformity marking and the issued Declaration of Conformity confirm that the equipment complies with all requirements and assessment procedures specified in the EC Directives. Essential in the EC DOC is the harmonized standards ref; http://eurlex.europa.eu/legalcontent/EN/TXT/PDF/?uri=uriserv:OJ.C_.2014.445.01.0005.01.ENG

Note:

According to Directive 94/9/EC the mandatory evidence of complying with this is given in the EC D.O.C. and the marking plate on the products including the operating instructions.

5.5 New ATEX Directive 2014 applicable from the 20th of April 2016

The new ATEX Directive 2014/34/EU on equipment and protective systems intended for use potentially explosive atmospheres is aligned with the "New Legislative Framework" and will be applicable from 20 April 2016.

There is no change to the Essential Requirements of Health and Safety as defined in Annex II. There is also no change in the various evaluation procedures. The terms of Annexes of the Directive, however, are modified.

Key changes against the old 94/9/EC directive:

- The directive also requires traceability of a product to be ensured throughout the whole supply chain. Therefore this directive clarifies requirements for manufacturers, authorized representatives, importers and distributors to make sure that products they place on the market comply with this directive
- From 20 April 2016 all products placed on the market need to comply with 2014/34/EU and a EU DOC (Declaration Of Conformity) need to be issued. Also the user instruction need to be revised by referring to the new directive
- All new certificates issued after 19 April 2016 will be named EU-Type Examination Certificate

Note:

All certificates issued according to 94/9/EC will still be valid if the products comply with 2014/34/EU (state of the art) and a EU DOC (Declaration Of Conformity) is issued before they are placed on the market. The New directive will not apply for products already placed on the market.

You will find further information on: <http://eur-lex.europa.eu/legal-content/EN/TXT/?uri=CELEX:32014L0034>

5.6 User Directive 1999/92/EC

This directive gives the minimum requirement for improving the safety and health protection of workers potentially at risk from explosive atmospheres.

The main issues to be addressed:

- Assessment of explosion risk
- Zone classification
- Explosion protection documents (including requirements for personnel to do engineering, equipment selection, installation, maintenance, repair, etc.)

5.7 Structure Directive 1999/92/EC

Ruling part		
Section	Article	Heading
I	1 - 2	General provisions
II	3 - 9	Obligations of the employer
	3	Prevention of and protection against explosions
	4	Assessment of the explosion risks
	5	General obligations
	6	Duty of coordination
	7	Places where explosive atmosphere may occur
	8	Explosion protection document
	9	Special requirements for work equipment and workplaces
	III	10- 15
Annexes		
I		Classification of places where explosive atmospheres may occur
		1. Places where explosive atmospheres may occur 2. Classification of hazardous places
II	A	Minimum requirements for the improvement of the safety and health protection of employees who could be endangered by explosive atmospheres
		1. Organizational measures 2. Explosion protection measures
	B	Criteria for the selection of equipment and protective systems
III		Warning signs for marking areas in which explosive atmospheres can occur

For further information (Directive 1999/92/EC and user guide) please visit:
http://ec.europa.eu/employment_social/health_safety/legislation_en.htm

6. Ignition sources

6.1 Classification of ignition sources for gas and vapours



6.2 Temperature class

Temperature class	Maximum surface temperature at ambient temperature
T1	450 °C
T2	300°C
T3	200°C
T4	135°C
T5	100°C
T6	85°C

6.3 Energy class

Minimum ignition energy	European groups	USA / Canada Groups	Gas e.g.
< 20 μ Joules	C	A	Acetylene, Carbon disulfide
< 20 μ Joules		B	Hydrogen
< 60 μ Joules	B	C	Ethyl ether, Ethylene
< 180 μ Joules	A	D	Acetone, Butane, Ethanol, Gasoline, Hexane, Methanol, Methane, Naphta, Propane

7. Standards

7.1 Standards valid for gas

Electrical Apparatus for Explosive Gas Atmospheres

	EN (old)	EN / IEC (Current)
General requirements	EN 50 014	EN 60079-0
Flameproof enclosures "d"	EN 50 018	EN 60079-1
Pressurized enclosures "p"	EN 50 016	EN 60079-2
Powder filling "q"	EN 50 017	EN 60079-5
Oil immersion "o"	EN 50 015	EN 60079-6
Increased safety "e"	EN 50 019	EN 60079-7
Intrinsic safety "i"	EN 50 020	EN 60079-11
Type of protection "n"	EN 50 021	EN 60079-15
Encapsulation "m"	EN 50 028	EN 60079-18
Intrinsically safe systems		EN 60079-25
Electrical equipment for Zone 0	EN 50 284	EN 60079-26
Intrinsically safe field bus systems		EN 60079-27
Optical radiation "op"		EN 60079-28

7.2 Standards valid for dust

Standard EN (IEC)	Protection name	Protection method
EN (IEC) 60079-31	t	Equipment , Dust ignition protection by enclosures "t"
61241-4	pD	Protected by pressurization

7.3 Standards valid for non-electrical equipment

Protection type	EN 13463-	Marking letter	New coming standards
Basic methods and requirements	-1		(EN) ISO/ IEC - 80079-36
Flow restriction	-2	fr	
Flameproof	-3	d	
Construction	-5	c	
Controlled ignition	-6	b	(EN) ISO/ IEC - 80079-37
Protected by oil	-8	k	

7.4 Standards valid for internal combustion motors

EN 1834-1	Gas, group II
EN 1834-2	Mines, group I
EN 1834-3	Dust, group II

7.5 Standards valid for safety industrial truck

EN 1755
Operation in potentially explosive atmosphere

8. Type of protection

8.1 Applicable type protection

Ex e - Increased safety

For electrical components that do not spark under normal working conditions but where measures are applied to prevent high temperatures and the occurrence of arcs and sparks internally.



Ex d - Flameproof enclosure

Parts, which can ignite a potentially explosive atmosphere, are surrounded by an enclosure, which are designed to withstand the pressure of an internal explosion and to prevent the propagation of the explosion to the atmosphere surrounding the enclosure.



Ex m - Encapsulation

Parts that could ignite a potentially explosive atmosphere by means of heat or sparks are embedded in a sealing compound such that the potentially explosive atmosphere cannot be ignited. The compound is resistant to physical, electrical, thermal and chemical influences.



Ex p - Pressurized enclosure

The formation of a potentially explosive atmosphere inside an enclosure is prevented by maintaining a positive internal pressure of protective gas in relation to the surrounding atmosphere and, where necessary, by supplying the inside of the enclosure with a constant flow of protective gas which dilutes any combustible mixtures.



Ex o - Oil immersion

Electrical equipment or parts of electrical equipment are immersed in a protective fluid (e.g. oil) in such a way that a potentially explosive atmosphere existing above the surface or outside of the encapsulation cannot be ignited.



Ex q - Powder filling

Filling the enclosure of electrical equipment with a fine grained packing material has the effect of making it impossible for an electric arc created in the enclosure under normal operating conditions to ignite a potentially explosive atmosphere surrounding the enclosure. Ignition must neither be caused by flames nor by elevated temperatures on the enclosure surface.



Ex i - Intrinsic safety

This protection providing measures to prevent the possibility of undue high temperatures developing and the occurrence of sparks or arcs inside or on outer parts of electrical equipment, which will not occur during regular operation, by an increased level of safety

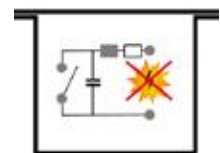

Protection Ex n

This protection only applies to electrical equipment of the 3G category, the intent being that during regular operation and certain abnormal conditions, the potential of this equipment igniting a surrounding explosive atmosphere is eliminated. This type of protection aims at finding an economical compromise between the "normal" industrial standard and the high technical safety requirements of the types of protection for equipment of the 2G category.



Ex t - Protection by enclosure

The enclosure is enough seal so that no flammable dust can penetrate inside. The external surface temperature of the housing is limited.



8.2 Equipment Protection Level (EPL) according to IEC/EN 60079-xx series OD standards

Definition:

The level of protection assigned to equipment based on its risk of becoming a source of ignition, and distinguishing the differences between explosive gas atmospheres, explosive dust atmospheres, and the explosive atmospheres which may exist in coal mines.

8.2 Link between ATEX and EPL

EN 60079-0			Directive 94-9-EC Product directive (Atex 100)		EN60079-10X	Directive 99/92/EC User directive (Atex 137)	
EPL	Group	Level of protection	Equipment group	Equipment category	Zones	Hazardous quantities	Extent of protective measure (risk)
Ma	I	Very high	I	M1	N/A	Without specific methane concentration	Safe with 2 faults, rare and foreseen
Mb		High		M2		With specific methane concentration	Safe with 1 fault, foreseen
Ga	II	Very high	II	1G	0	Often/longer periods	Safe with 2 faults, rare and foreseen
Gb		High		2G	1	Occasionally	Safe with 1 fault, foreseen
Gc		Enhanced		3G	2	Rear/most likely never	Normal
Da	III	Very high	III	1D	20	Often/longer periods	Safe with 2 faults, rare and foreseen
Db		High		2D	21	Occasionally	Safe with 1 fault, foreseen
Dc		Enhanced		3D	22	Rear/most likely never	Normal

8.3 Why EPL (ATEX categories)

Historically it has been acceptable to install equipment into specific zones based on the type of protection.

In some cases it has been shown that the type of protection may be divided into different levels of protection that can be correlated against each Zone. A better risk assessment would consider all factors.

When using a risk assessment approach instead of the inflexible approach of the past linking equipment to Zones the inherent ignition risk of the equipment is clearly indicated, no matter what type of protection is used.

An example using a risk assessment approach:

Plant operators often make intuitive decisions on extending (or restricting) their Zones in order to compensate for this inflexibility. A typical example is the installation of “Zone 1 Type” navigation equipment in Zone 2 areas of offshore oil production platforms, so that the navigation equipment can remain functional even in the presence of a totally unexpected and prolonged gas release.





On the other hand, it is reasonable for the owner of a remote, well secured, small pumping station to drive the pump with a “Zone 2 Type” motor, even in Zone 1, if the total amount of gas available to explode is small and the risk to life and property from such as explosion can be discounted.

The situation became more complex with the publication of the first edition of IEC 60079-26 which introduced additional requirements to be applied for equipment intended to be used in Zone 0. Prior to this, Ex ia was considered to be the only technique acceptable in Zone 0.

It has been recognized that it is beneficial to identify and mark all products according to their inherent ignition risk. This makes equipment selection easier and a risk assessment approach, more appropriate.

9. New marking for Ex equipment



9.1 New marking for Gas equipment

ATEX	Old Gas atmosphere	New IEC 60079-0:2011/EN 60079-0:2012
 II 2 G	Ex d IIB T6	Ex d IIB T6 Gb or Ex db IIB T6*
 II 2(1) G	Ex d [ia IIC] IIB T6	Ex d [ia IIC Ga] IIB T6 Gb or Ex db [ia IIC] IIB T6*
 II 2 G	Ex ib IIC T4	Ex ib IIC T4 Gb or Ex ib IIC T4*
 II 2 G	Ex e II T4	Ex e IIC T4 Gb or Ex eb IIC T4*

*IEC alternate marking

Protection principles and marking for explosive gas atmosphere	Marking according to EN (IEC) 60079-1: 21012			Alternative marking and coming marking		
	Ga	Gb	Gc	Ga	Gb	Gc
Equipment protection level (EPL)						
Flameproof enclosure		d		da	db	dc
Increased safety		e			eb	ec
Intrinsic safety	ia	ib	ic	ia	ib	ic
Encapsulation	ma	mb	mc	ma	mb	mc
Non-sparking			nA			nAc
Protected sparking			nC			nCc
Restricted sparking			nR			nRc
Oil immersion		o			ob	oc
Pressurization		px py	pz pv		pxb pyb	PVC pzv
Powder filling		q			qb	

9.1 New marking for Dust equipment

ATEX	Old Dust atmosphere	New IEC 60079-0:2011/EN 60079-0:2012
 II 2 D	Ex tD A21 IP65 T120°C	Ex tb IIIC T120°C Db or Ex tb IIIC T120°C*
 II 2(1) D	Ex tD [iaD] A21 IP65 T120°C	Ex tb [ia Da] IIIC T120°C Db or Ex tb [ia] IIIC T120°C*
 II 2 D	Ex iaD A20 IP65 T120°C	Ex ia IIIC T120°C Da or Ex ia IIIC T120°C*

*IEC alternate marking

Protection principles and marking for explosive dust atmosphere	Marking according to EN (IEC) 60079-1: 21012			Alternative marking and coming marking		
	Da	Db	Dc	Da	Db	Dc
Equipment protection level (EPL)						
Protected by enclosure	ta	tb	tc	ta	tb	tc
Intrinsic safety	ia	ib		ia	ib	ic
Encapsulation	ma	mb		ma	mb	mc
Pressurization		p	p		pb	pc

The Ex marking for explosive gas and dust atmospheres shall be separate and not combined:

II 1 G - Ex ia IIB T4 Ga
 II 1 D - Ex ia IIIC T120°C Da

alternatively

II 1 GD
 Ex ia IIB T4 Ga
 Ex ia IIIC T120°C Da

or

II 1 GD
 Ex ia IIB T4
 Ex ia IIIC T120°C

10. IP protection

IP code according to IEC/EN standard 60529

First digit: protection against solid particules		Second digit: protection against liquid ingress	
IP	Protected against	IP	Protected against
0	No protection	0	No protection
1	Protected against a solid object 50 mm or greater	1	Protected against vertically dripping water
2	Protected against a solid object 12.5 mm or greater	2	Protected against vertically dripping water, when tilted 15 degrees
3	Protected against a solid object 2.5 mm or greater	3	Protected against water spraying at an angle up to 60 degree
4	Protected against a solid object 1 mm or greater	4	Protected against water splashing from any direction
5	Dust protected	5	Protected against jets of water from any directions
6	Dust tight	6	Protected against powerful jets of water from any directions
		7	Protected against temporary immersion into water up to 1 meter
		8	Protected against prolonged immersion into water beyond 1 meter
		9K	Protected against powerful high temperature water jets

11. IK protection

IK code according to EN 62252

IK	Impact energy (joules)	Protected against
00	Unprotected	No test
01	0.15	Drop of 200 g object from 7.5 cm height
02	0.2	Drop of 200 g object from 10 cm height
03	0.35	Drop of 200 g object from 17.5 cm height
04	0.5	Drop of 200 g object from 25 cm height
05	0.7	Drop of 200 g object from 35 cm height
06	1	Drop of 500 g object from 20 cm height
07	2	Drop of 500 g object from 40 cm height
08	5	Drop of 1.7 kg object from 29.5 cm height
09	10	Drop of 5 kg object from 20 cm height
10	20	Drop of 5 kg object from 40 cm height



Control Stations

Content

Page

Control Stations - Increased safety

Glass-reinforced polyester XAWG series

22

Aluminium XAWF series

24

Stainless steel XAWFS series

26

Control Stations - Flameproof

Aluminium XADW series - Explosion gas group IIB

28

Aluminium XAEW series - Explosion gas group IIC

28

Pendant Stations - Increased safety

Glass-reinforced polyester XAWP series

30

Fire Alarm Stations - Increased safety

Glass-reinforced polyester XAWS series

36





The control stations XAWG, made in glass-reinforced polyester (GRP), are equipped with our extensive range of robust and flexible control and signalling units HarmAtex.

They combine the functions start and stop for motors, fans, pumps ..., and they can be provided with measuring instruments for current control, voltage or other physical quantities.

The functions can be predefined or determined according to the requirement of the application. Up to 48 control and signalling units can be installed on the XAWG control units.

TECHNICAL DATA

Material	Glass-reinforced polyester (GRP)
IP rating	IP65 according to EN/IEC 60529
Temperature range	-20°C ... +40°C or +50°C or +60°C
Certificate	INERIS 03ATEX0122X
Marking	II 2 GD Ex e IIC T6...T4 Gb Ex e mb IIC T6...T4 Gb Ex d e IIC T6...T4 Gb Ex d e mb IIC T6...T4 Gb Ex tb IIIC T85°C ... T135°C Db
Features of the contact block	Ith = 10 A; Ui = 415 V AC Ue = 380 V; Ie = 1,9 A or Ue = 240 V; Ie = 3 A or Ue = 120 V; Ie = 6 A DC Ue = 250 V; Ie = 0,27 A or Ue = 125 V; Ie = 0,55 A or Ue = 24 V; Ie = 2,87 A
Features of the LED pilot light	Rated voltage 24 ... 254 V AC/DC Maximal current 2 ... 10 mA
Mechanical endurance of the push buttons	Head: 5 million operations - Contact block: 1 million operations

Product code	Actuator	Colour	Label	Contact
XAWG10	1 x Push button, spring to return	● Green	Start	1NO
XAWG11	1 x Push button, spring to return	● Red	Stop	1NC
XAWG16	1 x Mushroom, spring to return - Ø 40 mm	● Red	Emergency stop	1NC
XAWG15	1 x Mushroom, Push-Pull - Ø 40 mm	● Red	Emergency stop	1NC
XAWG17	1 x Mushroom, turn to release - Ø 40 mm	● Red	Emergency stop	1NC
XAWG172	1 x Mushroom, release by key - Ø 40 mm	● Red	Emergency stop	1NC
XAWG13	1 x Selector switch, 2 stay put positions	● Black	Start - Stop	1NO
XAWG132	1 x Selector switch, 2 stay put positions	● Black	Manu - Auto	1NO+1NC
XAWG133	1 x Selector switch, 2 stay put positions	● Black	0-I	1NO+1NC
XAWG12	1 x Selector switch, 3 stay put positions	● Black	I-0-II	1NO+1NC
XAWG121	1 x Selector switch, 3 spring return to center	● Black	I-0-II	1NO+1NC
XAWG122	1 x Selector switch, key withdrawal in 3 positions	● Black	I-0-II	1NO+1NC
XAWG143	1 x Pilot light, integral LED - 24 to 254 V AC-DC	● Green	Blank	-
XAWG144	1 x Pilot light, integral LED - 24 to 254 V AC-DC	● Red	Blank	-
XAWG147	1 x Pilot light, integral LED - 24 to 254 V AC-DC	○ White	Blank	-
XAWG146	1 x Pilot light, integral LED - 24 to 254 V AC-DC	● Blue	Blank	-
XAWG145	1 x Pilot light, integral LED - 24 to 254 V AC-DC	● Yellow	Blank	-

Product code	Actuator	Colour	Label	Contact
XAWG21	1 x Push button, spring to return	● Green	Start	1NO
	1 x Push button, spring to return	● Red	Stop	1NC
XAWG26	1 x Push button, spring to return	● Green	Start	1NO
	1 x Mushroom, spring to return - Ø 40 mm	● Red	Emergency stop	1NC
XAWG25	1 x Push button, spring to return	● Green	Start	1NO
	1 x Mushroom, Push-Pull - Ø 40 mm	● Red	Emergency stop	1NC
XAWG27	1 x Push button, spring to return	● Green	Start	1NO
	1 x Mushroom, turn to release - Ø 40 mm	● Red	Emergency stop	1NC
XAWG272	1 x Push button, spring to return	● Green	Start	1NO
	1 x Mushroom, release by key - Ø 40 mm	● Red	Emergency stop	1NC
XAWG24	1 x Push button, spring to return	● Green	Star	1NO
	1 x Pilot light, integral LED - 24 to 254 V AC-DC	● Green	Blank	-
XAWG244	1 x Push button, spring to return	● Black	Start	1NO
	1 x Pilot light, integral LED - 24 to 254 V AC-DC	● Red	Blank	-
XAWG31	1 x Push button, spring to return	● Green	Forward	1NO
	1 x Push button, spring to return	● Red	Stop	1NC
	1 x Push button, spring to return	● Green	Reverse	1NO
XAWG37	1 x Push button, spring to return	● Green	Start	1NO
	1 x Push button, spring to return	● Red	Stop	1NC
	1 x Mushroom, spring to return Ø 40 mm	● Red	Emergency stop	1NC
XAWG34	1 x Push button, spring to return	● Green	Start	1NO
	1 x Push button, spring to return	● Red	Stop	1NC
	1 x Pilot light, integral LED - 24 to 254 V AC-DC	● Green	Blank	-
XAWG393	1 x Push button, spring to return	● Green	Start	1NO
	1 x Mushroom, Push-Pull Ø 40 mm	● Red	Emergency stop	1NC
	1 x Pilot light, integral LED - 24 to 254 V AC-DC	● Green	Blank	-

Any other configuration on request

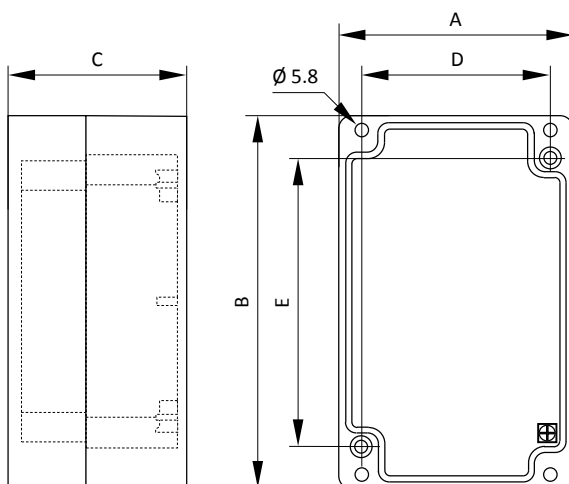

Enclosure	A	B	C	D	E
XAWG 1...	85	146	70	70	105
XAWG 2...	85	146	70	70	105
XAWG 3...	85	226	70	70	108
XAWG 5...	85	281	70	70	240
XAWG 8...	151	241	87	135	200

Other dimensions on request



The control stations XAWF, made in aluminium, are equipped with our extensive range of robust and flexible control and signalling units HarmAtex.

They combine the functions start and stop for motors, fans, pumps ..., and they can be provided with measuring instruments for current control, voltage or other physical quantities.

The functions can be predefined or determined according to the requirement of the application. Up to 52 control and signalling units can be installed on the XAWF control units.

TECHNICAL DATA

Material	Aluminium
IP rating	IP65 according to EN/IEC 60529
Temperature range	-20°C ... +40°C or +50°C or +60°C
Certificate	INERIS 03ATEX0122X
Marking	II 2 GD Ex e IIC T6...T4 Gb Ex e mb IIC T6...T4 Gb Ex d e IIC T6...T4 Gb Ex d e mb IIC T6...T4 Gb Ex tb IIIC T85°C ... T135°C Db
Features of the contact block	Ith = 10 A; Ui = 415 V AC Ue = 380 V; Ie = 1,9 A or Ue = 240 V; Ie = 3 A or Ue = 120 V; Ie = 6 A DC Ue = 250 V; Ie = 0,27 A or Ue = 125 V; Ie = 0,55 A or Ue = 24 V; Ie = 2,87 A
Features of the LED pilot light	Rated voltage 24 ... 254 V AC/DC Maximal current 2 ... 10 mA
Mechanical endurance of the push buttons	Head: 5 million operations - Contact block: 1 million operations

Product code	Actuator	Colour	Label	Contact
XAWF10	1 x Push button, spring to return	● Green	Start	1NO
XAWF11	1 x Push button, spring to return	● Red	Stop	1NC
XAWF16	1 x Mushroom, spring to return - Ø 40 mm	● Red	Emergency stop	1NC
XAWF15	1 x Mushroom, Push-Pull - Ø 40 mm	● Red	Emergency stop	1NC
XAWF17	1 x Mushroom, turn to release - Ø 40 mm	● Red	Emergency stop	1NC
XAWF172	1 x Mushroom, release by key - Ø 40 mm	● Red	Emergency stop	1NC
XAWF13	1 x Selector switch, 2 stay put	● Black	Start - Stop	1NO
XAWF132	1 x Selector switch, 2 stay put	● Black	Manu - Auto	1NO+1NC
XAWF133	1 x Selector switch, 2 stay put	● Black	0-I	1NO+1NC
XAWF12	1 x Selector switch, 3 stay put	● Black	I-0-II	1NO+1NC
XAWF121	1 x Selector switch, 3 spring return to center	● Black	I-0-II	1NO+1NC
XAWF122	1 x Selector switch, key withdrawal in 3 positions	● Black	I-0-II	1NO+1NC
XAWF143	1 x Pilot light, integral LED - 24 to 254 V AC-DC	● Green	Blank	-
XAWF144	1 x Pilot light, integral LED - 24 to 254 V AC-DC	● Red	Blank	-
XAWF147	1 x Pilot light, integral LED - 24 to 254 V AC-DC	○ White	Blank	-
XAWF146	1 x Pilot light, integral LED - 24 to 254 V AC-DC	● Blue	Blank	-
XAWF145	1 x Pilot light, integral LED - 24 to 254 V AC-DC	● Yellow	Blank	-

Product code	Actuator	Colour	Label	Contact
XAWF21	1 x Push button, spring to return	● Green	Start	1NO
	1 x Push button, spring to return	● Red	Stop	1NC
XAWF26	1 x Push button, spring to return	● Green	Start	1NO
	1 x Mushroom, spring to return - Ø 40 mm	● Red	Emergency stop	1NC
XAWF25	1 x Push button, spring to return	● Green	Start	1NO
	1 x Mushroom, Push-Pull - Ø 40 mm	● Red	Emergency stop	1NC
XAWF27	1 x Push button, spring to return	● Green	Start	1NO
	1 x Mushroom, turn to release - Ø 40 mm	● Red	Emergency stop	1NC
XAWF272	1 x Push button, spring to return	● Green	Start	1NO
	1 x Mushroom, release by key - Ø 40 mm	● Red	Emergency stop	1NC
XAWF24	1 x Push button, spring to return	● Green	Start	1NO
	1 x Pilot light, integral LED - 24 to 254 V AC-DC	● Green	Blank	-
XAWF244	1 x Push button, spring to return	● Black	Start	1NO
	1 x Pilot light, integral LED - 24 to 254 V AC-DC	● Red	Blank	-
XAWF31	1 x Push button, spring to return	● Green	Forward	1NO
	1 x Push button, spring to return	● Red	Stop	1NC
	1 x Push button, spring to return	● Green	Reverse	1NO
XAWF37	1 x Push button, spring to return	● Green	Start	1NO
	1 x Push button, spring to return	● Red	Stop	1NC
	1 x Mushroom, spring to return Ø 40 mm	● Red	Emergency stop	1NC
XAWF34	1 x Push button, spring to return	● Green	Start	1NO
	1 x Push button, spring to return	● Red	Stop	1NC
	1 x Pilot light, integral LED - 24 to 254 V AC-DC	● Green	-	-
XAWF393	1 x Push button, spring to return	● Green	Start	1NO
	1 x Mushroom, Push-Pull Ø 40 mm	● Red	Emergency stop	1NC
	1 x Pilot light, integral LED - 24 to 254 V AC-DC	● Green	Blank	-

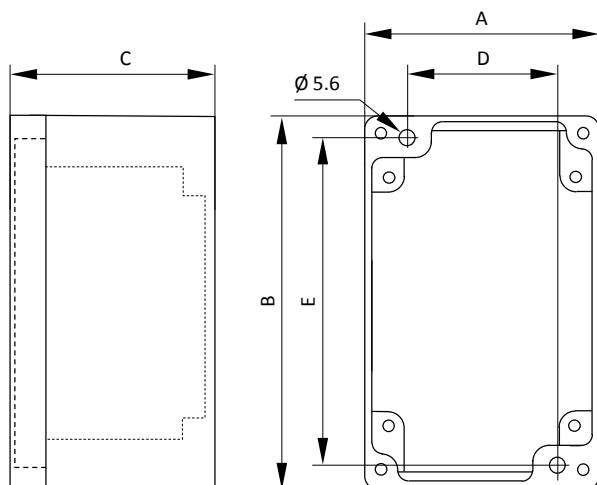

Any other configuration on request



Enclosure	A	B	C	D	E
XAWF 1...	80	80	77	50	65
XAWF 2...	80	130	77	50	115
XAWF 3...	80	175	77	50	160
XAWF 4...	80	220	77	50	205
XAWF 6...	85	310	77	55	295

Other dimensions on request



The control stations XAWFS, made in stainless steel AISI 316L, are equipped with our extensive range of robust and flexible control and signalling units HarmAtex.

They combine the functions start and stop for motors, fans, pumps ..., and they can be provided with measuring instruments for current control, voltage or other physical quantities.

The functions can be predefined or determined according to the requirement of the application. Up to 52 control and signalling units can be installed on the XAWFS control units.

TECHNICAL DATA

Material	Stainless steel AISI 316L
IP rating	IP65 according to EN/IEC 60529
Temperature range	-20°C ... +40°C or +50°C or +60°C
Certificate	INERIS 03ATEX0122X
Marking	II 2 GD Ex e IIC T6...T4 Gb Ex e mb IIC T6...T4 Gb Ex d e IIC T6...T4 Gb Ex d e mb IIC T6...T4 Gb Ex tb IIIC T85°C ... T135°C Db
Features of the contact block	Ith = 10 A; Ui = 415 V AC Ue = 380 V; Ie = 1,9 A or Ue = 240 V; Ie = 3 A or Ue = 120 V; Ie = 6 A DC Ue = 250 V; Ie = 0,27 A or Ue = 125 V; Ie = 0,55 A or Ue = 24 V; Ie = 2,87 A
Features of the LED pilot light	Rated voltage 24 ... 254 V AC/DC Maximal current 2 ... 10 mA
Mechanical endurance of the push buttons	Head: 5 million operations - Contact block: 1 million operations

Product code	Actuator	Colour	Label	Contact
XAWFS10	1 x Push button, spring to return	● Green	Start	1NO
XAWFS11	1 x Push button, spring to return	● Red	Stop	1NC
XAWFS16	1 x Mushroom, spring to return - Ø 40 mm	● Red	Emergency stop	1NC
XAWFS15	1 x Mushroom, Push-Pull - Ø 40 mm	● Red	Emergency stop	1NC
XAWFS17	1 x Mushroom, turn to release - Ø 40 mm	● Red	Emergency stop	1NC
XAWFS172	1 x Mushroom, release by key - Ø 40 mm	● Red	Emergency stop	1NC
XAWFS13	1 x Selector switch, 2 stay put	● Black	Start - Stop	1NO
XAWFS132	1 x Selector switch, 2 stay put	● Black	Manu - Auto	1NO+1NC
XAWFS133	1 x Selector switch, 2 stay put	● Black	0-I	1NO+1NC
XAWFS12	1 x Selector switch, 3 stay put	● Black	I-0-II	1NO+1NC
XAWFS121	1 x Selector switch, 3 spring return to center	● Black	I-0-II	1NO+1NC
XAWFS122	1 x Selector switch, key withdrawal in 3 positions	● Black	I-0-II	1NO+1NC
XAWFS143	1 x Pilot light, integral LED - 24 to 254 V AC-DC	● Green	Blank	-
XAWFS144	1 x Pilot light, integral LED - 24 to 254 V AC-DC	● Red	Blank	-
XAWFS147	1 x Pilot light, integral LED - 24 to 254 V AC-DC	○ White	Blank	-
XAWFS146	1 x Pilot light, integral LED - 24 to 254 V AC-DC	● Blue	Blank	-
XAWFS145	1 x Pilot light, integral LED - 24 to 254 V AC-DC	● Yellow	Blank	-

Product code	Actuator	Colour	Label	Contact
XAWFS21	1 x Push button, spring to return	● Green	Start	1NO
	1 x Push button, spring to return	● Red	Stop	1NC
XAWFS26	1 x Push button, spring to return	● Green	Start	1NO
	1 x Mushroom, spring to return - Ø 40 mm	● Red	Emergency stop	1NC
XAWFS25	1 x Push button, spring to return	● Green	Start	1NO
	1 x Mushroom, Push-Pull - Ø 40 mm	● Red	Emergency stop	1NC
XAWFS27	1 x Push button, spring to return	● Green	Start	1NO
	1 x Mushroom, turn to release - Ø 40 mm	● Red	Emergency stop	1NC
XAWFS272	1 x Push button, spring to return	● Green	Start	1NO
	1 x Mushroom, release by key - Ø 40 mm	● Red	Emergency stop	1NC
XAWFS24	1 x Push button, spring to return	● Green	Start	1NO
	1 x Pilot light, integral LED - 24 to 254 V AC-DC	● Green	Blank	-
XAWFS244	1 x Push button, spring to return	● Black	Start	1NO
	1 x Pilot light, integral LED - 24 to 254 V AC-DC	● Red	Blank	-
XAWFS31	1 x Push button, spring to return	● Green	Forward	1NO
	1 x Push button, spring to return	● Red	Stop	1NC
	1 x Push button, spring to return	● Green	Reverse	1NO
XAWFS37	1 x Push button, spring to return	● Green	Start	1NO
	1 x Push button, spring to return	● Red	Stop	1NC
	1 x Mushroom, spring to return Ø 40 mm	● Red	Emergency stop	1NC
XAWFS34	1 x Push button, spring to return	● Green	Start	1NO
	1 x Push button, spring to return	● Red	Stop	1NC
	1 x Pilot light, integral LED - 24 to 254 V AC-DC	● Green	Blank	-
XAWFS393	1 x Push button, spring to return	● Green	Start	1NO
	1 x Mushroom, Push-Pull Ø 40 mm	● Red	Emergency stop	1NC
	1 x Pilot light, integral LED - 24 to 254 V AC-DC	● Green	Blank	-

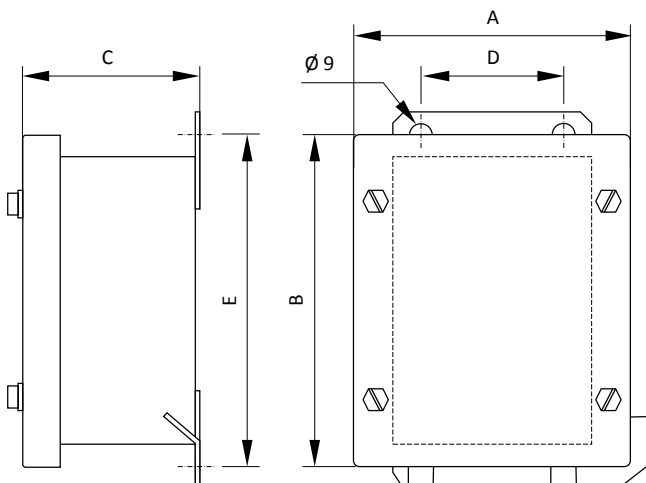

Any other configuration on request



Enclosure	A	B	C	D	E
XAWFS 1...	125	110	80	65	110
XAWFS 2...	125	150	80	65	150
XAWFS 3...	125	195	80	65	195
XAWFS 4...	125	240	80	65	240
XAWFS 5...	125	295	80	65	295
XAWFS 6...	125	330	80	65	330

Other dimensions on request



Extremely robust, the control stations XADW and XAEW are mainly used for the control.

They are equipped with control and signalling units having a very long operating time.

Consisting of push buttons, pilot lights, switches, potentiometers or ammeters, these control stations are equipped as standard with nickel-plated brass cable glands.

TECHNICAL DATA

Material	Aluminium
IP rating	IP65/66 according to EN/IEC 60529
Temperature range	-20°C ... +40°C or +60°C
Certificate	INERIS 03ATEX0145 for XADW INERIS 03ATEX0146 for XAEW
Marking	II 2 GD Ex d IIB T6 Gb for XADW Ex d IIC T6 Gb for XAEW Ex tb IIIC T85°C Db for XADW and XAEW
Features of the contact block	Ith = 10 A; Ui = 500 V AC Ue = 500 V; Ie = 1,2 A or Ue = 240 V; Ie = 3 A or Ue = 120 V; Ie = 6 A DC Ue = 500 V; Ie = 0,1 A or Ue = 250 V; Ie = 0,27 A or Ue = 125 V; Ie = 0,55 A
Mechanical endurance of the push buttons	Head: 5 million operations - Contact block: 1 million operations
Surface treatment	Painting RAL 7032 - Other colour available upon request
Cable entry	Fitted with one M20 nickel-plated brass cable gland

Product code for GAS group IIB		Product code for GAS group IIC		Actuator			
For unarmoured cable	For armoured cable	For unarmoured cable	For armoured cable	Description	Colour	Label	Contact
XADW12110P11IC	XADW12111P14I	XAEW12110P11IC	XAEW12111P14I	1 x Push button, spring return	● Black	Start	1NO
XADW12111P11IC	XADW12111P14I	XAEW12111P11IC	XAEW12111P14I	1 x Push button, spring return	● Red	Stop	1NC
XADW12116P11IC	XADW12116P14I	XAEW12116P11IC	XAEW12116P14I	1 x Mushroom, spring return	● Red	Stop	1NC
XADW12113P11IC	XADW12113P14I	XAEW12113P11IC	XAEW12113P14I	1 x Selector switch, 2 stay put	● Black	Start-Stop	1NC
XADW12221P11IC	XADW12221P14I	XAEW12221P11IC	XAEW12221P14I	1 x Push button, spring return	● Black	Start	1NO
				1 x Push button, spring return	● Red	Stop	1NC
XADW13231P11IC	XADW13231P14I	XAEW13231P11IC	XAEW13231P14I	1 x Push button, spring return	● Black	Forward	1NO
				1 x Push button, spring return	● Red	Stop	1NC
				1 x Push button, spring return	● Black	Reverse	1NO
XADW13236P11IC	XADW13236P14I	XAEW13236P11IC	XAEW13236P14I	1 x Push button, spring return	● Black	Start	1NO
				1 x Push button, spring return	● Red	Stop	1NC
				1 x Pilot light, 24 to 254 V	● Red	Blank	-
XADW1231P11IC	XADW1231P14I	XAEW1231P11IC	XAEW1231P14I	1 x Ammeter	-	-	-
XADW122321P11IC	XADW122321P14I	XAEW122321P11IC	XAEW122321P14I	1 x Ammeter	-	-	-
				1 x selector switch 2 positions	● Black	Start-Stop	1NO
XADW132321P11IC	XADW132321P14I	XAEW132321P11IC	XAEW132321P14I	1 x Ammeter	-	-	-
				1 x Push button, spring return	● Black	Start	1NO
				1 x Push button, spring return	● Red	Stop	1NC

Empty boxes for variable composition stations assembled by Ex-tech Solution

Group IIB T6	With circular gasket (for gas group and vapours IIB)		
	Entry M20	Positions	Product code
1 push button or 1 pilot light	1	A	XADW12101
	2	A - C	XADW12102
2 push buttons or pilot lights	1	A	XADW12201
	2	A - C	XADW12202
3 push buttons or pilot lights	1	A	XADW13201
	2	A - C	XADW13202
4 to 6 push buttons or pilot lights	1	A	XADW22301
	2	A - C	XADW22302
	2	L - M	XADW22303
Only for one ammeter Ø 48mm	1	A	XADW12301
	2	A - C	XADW12302
1 Ammeter Ø 48mm and 1 push button or pilot light	1	A	XADW122301
	2	A - C	XADW122302
1 Ammeter Ø 48mm and 2 push buttons or pilot lights	1	A	XADW132301
	2	A - C	XADW132302
1 Ammeter Ø 48mm and 4 push buttons or pilot lights	1	A	XADW224301
	2	A - C	XADW224302
	2	L - M	XADW224303

Group IIC T6	With circular gasket (for gas group and vapours IIC)		
	Entry M20	Positions	Product code
1 push button or 1 pilot light	1	A	XAEW12101
	2	A - C	XAEW12102
	2	L - M	XAEW12103
2 push buttons or pilot lights	1	A	XAEW12201
	2	A - C	XAEW12202
	2	L - M	XAEW12203
Only for one ammeter	1	A	XAEW12301
	2	A - C	XAEW12302
	2	L - M	XAEW12303

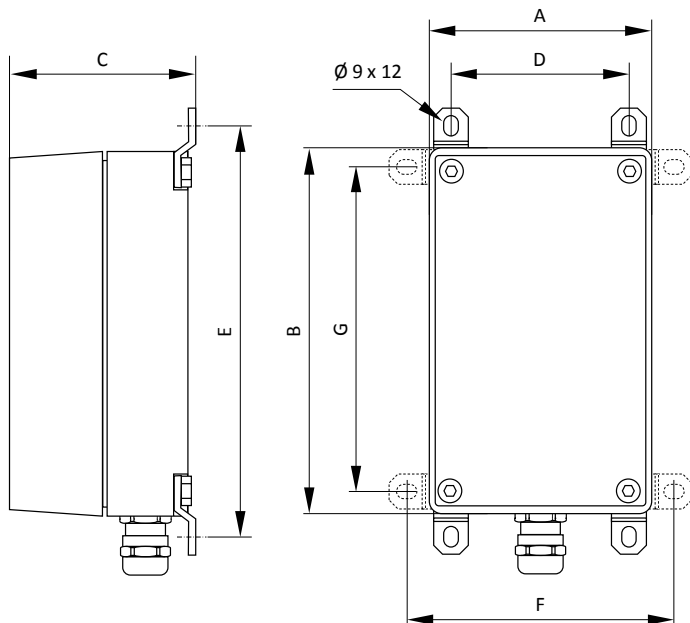

Any other configuration on request



Enclosure	A	B	C	D	E	F	G
XADW12...	106	150	89	80	175	130	125
XADW13...	106	190	89	80	215	130	165
XADW22...	130	215	89	105	240	155	190
XAEW...	130	130	89	105	160	160	105

Pendant stations

Increased safety - Group IIC XAWP series



The pendant stations XAWP are suitable for all types of industry and primarily used on overhead cranes, cranes.

They are available with 2, 4, 6 or 8 push buttons and with up to three contact blocks per push button. The XAWP also features an optional double-step actuation mode for dual speed control.

They will be most often customized and can be coupled for 12 or 16 channels control.

TECHNICAL DATA

Material	Glass-reinforced polyester (GRP)
IP rating	IP65 according to EN/IEC 60529
Temperature range	-20°C ... +60°C
Certificate	INERIS03ATEX0122X
Marking	II 2 GD Ex d e IIC T6 Gb Ex d e mb IIC T6 Gb Ex tb IIIC T85°C Db
Features of the contact block	Ith = 10 A; Ui = 415 V AC Ue = 380 V; Ie = 1,9 A or Ue = 240 V; Ie = 3 A or Ue = 120 V; Ie = 6 A DC Ue = 250 V; Ie = 0,27 A or Ue = 125 V; Ie = 0,55 A or Ue = 24 V; Ie = 2,87 A
Features of the LED pilot light	Rated voltage 24 ... 254 V AC/DC Maximal current 2 ... 10 mA
Mechanical endurance of the push buttons	Head: 5 million operations - Contact block: 1 million operations
Cable entry	For cable Ø 10 to Ø 22 mm
Customized solution	On request









2 XAWP-... accouplées





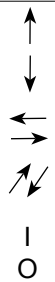

XAWP4...



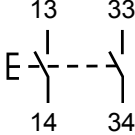

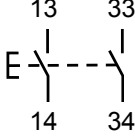
Complete control stations

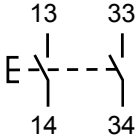
Fitted with interchangeable operators and cable boot suitable for Ø 10 to Ø 22 mm cable					
Number of ways	Function	Contact blocks mounted on each way		Product code	Weight (kg)
2		 1 NO		XAWP271	0,940
		 1 NC + 1 NO		XAWP281	1,000
4		 1 NO		XAWP471	1,290
		 1 NC + 1 NO		XAWP481	1,400
6		 1 NO		XAWP671	1,650
		 1 NC + 1 NO		XAWP681	1,800
Fitted with interchangeable push-buttons, start and emergency stop functions. Cable boot suitable for Ø 10 to Ø 22 mm cable					
Number of ways	Function	Contact blocks mounted on each way		Product code	Weight (kg)
4		 1 NO for Direction and Start functions	 1 NF for Stop function	XAWP472	1,320
		 1 NO for Direction and Start functions	 1 NC + 1 NO for all functions		XAWP482
6		 1 NO for Direction and Start functions	 1 NF for Stop function	XAWP672	1,650
		 1 NO for Direction and Start functions	 1 NC + 1 NO for all functions		XAWP682
8		 1 NO for Direction and Start functions	 1 NF for Stop function	XAWP872	2,000
		 1 NO for Direction and Start functions	 1 NC + 1 NO for all functions		XAWP882

Double step push-button stations

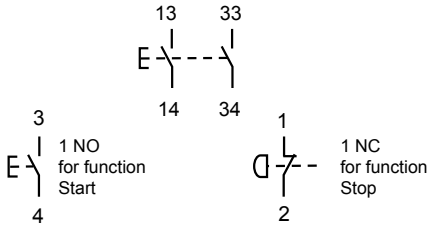
Fitted with "double" step mechanism on each push button. Cable boot suitable for Ø 10 to Ø 22 mm cable				
Number of way	Function	Contact element	Product code	Weight (kg)
2			XAWP2271	1,000
4			XAWP4271	1,400
6			XAWP6271	1,800

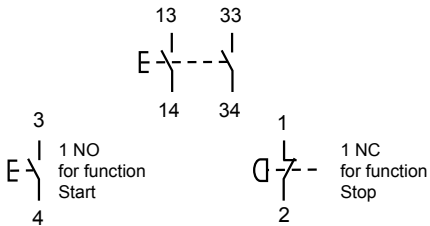
Double step push button stations

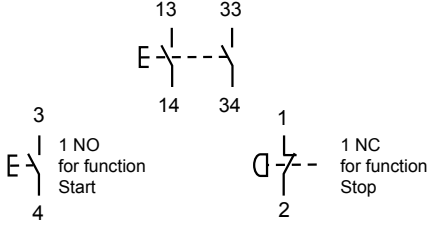
Fitted with "double" step mechanism on each direction cable button, start push button, red Ø 40 mm. Mushroom head latching to release. Cable boot suitable for Ø 10 to Ø 22 mm cable				
Number of way	Function	Contact element	Product code	Weight (kg)
4			XAWP4272 with standard push button "Start"	1,350
6			XAWP6272 with standard push button "Start"	1,800
8			XAWP8272 with standard push button "Start"	2,250

Accessories and spare parts

Accessories and spare parts		
Type	Function	Product code
Empty pendant control station for mounting exclusively by Ex-tech Solution	02 buttons	XAWP029
	04 buttons	XAWP049
	06 buttons	XAWP069
	08 buttons	XAWP089
	12 buttons	XAWP069D
	16 buttons	XAWP089D
Slow break contact element (For technical features please refer to page 34)	NO	ZBWE101
	NC	ZBWE102
Complete booted push button operator	○ White	XAWP9411
	● Black	XAWP9412
	● Green	XAWP9413
	● Red	XAWP9414
		XAWP9414
Selector switch + contact	2 fixed positions - Black	XBW5AD21
	3 fixed positions - Black	XBW5AD33
Multitension pilot light (24V ... 254 V AC-DC)	○ White	XLW5AV013-XAWP
	● Green	XLW5AV033-XAWP
	● Red	XLW5AV043-XAWP
	● Yellow	XLW5AV053-XAWP
	● Blue	XLW5AV063-XAWP
Blank plug		XAWZ3
Double push buttons interlocked each with 2 steps (only with ZBWE101 contact blocks)	Labels to specify	XAWP94VV
Double push buttons interlocked each with 2 steps (only with ZBWE101 contact blocks)	Labels UP and DOWN	XAWP94MD
Double push buttons interlocked each with 2 steps (only with ZBWE101 contact blocks)	Labels LEFT and RIGHT	XAWP94GD
Double push buttons interlocked each with 2 steps (only with ZBWE101 contact blocks)	Labels FORWARD and REVERSE	XAWP94AA
Double step push buttons WITHOUT INTERLOCK (only with ZBWE101 contact blocks)	○ White	XAWP9421
	● Black	XAWP9422
Emergency Mushroom head (Ø40)		XBW5AS844-XAWP
Emergency Mushroom head (Ø30)		XBW5AS834-XAWP



XAWP9411



XLW5AV033-XAWP

Arrow for double step push button		Arrow for single step push button	
Type	Product code	Type	Product code
UP	ZBWY4953	UP	ZBWY4951
DOWN	ZBWY2956	DOWN	ZBWY2954
RIGHT	ZBWY4903	RIGHT	ZBWY4901
LEFT	ZBWY2906	LEFT	ZBWY2904
FORWARD	ZBWY4965	FORWARD	ZBWY4963
REVERSE	ZBWY2968	REVERSE	ZBWY2966
		FAST UP	ZBWY4952
		FAST DOWN	ZBWY2955
		FAST RIGHT	ZBWY4902
		FAST LEFT	ZBWY2905
		FAST FORWARD	ZBWY4964
		FAST REVERSE	ZBWY2967
		I	ZBWY4980
		O	ZBWY2931
		O - I	ZBWY2178
		I - II	ZBWY2179
		I - O - II	ZBWY2186
		EMERGENCY STOP	ZBWY2330

Additional contact blocks

Features of the contact block

Temperature range	-50°C ... +75°C	Electrical features	I _{th} = 10 A; U _i = 415 V
Certificate	INERIS 02ATEX9007U		AC U _e = 380 V; I _e = 1,9 A or U _e = 240 V; I _e = 3 A or U _e = 120 V; I _e = 6 A
Marking	IECEX INE 13.0063U		DC U _e = 250 V; I _e = 0,27 A or U _e = 125 V; I _e = 0,55 A or U _e = 24 V; I _e = 2,87 A
	II 2 G		
	Ex d e IIC Gb		

Type	Product code	Description
	ZBWE101	NO
	ZBWE102	NC

LED Signalling element

Type	Colour	Codes for 24 to 254 V AC/DC	Codes for 6 to 24 V AC/DC
	○ White	ZBWW1 (1)	ZBWW1B (1)
	● Green	ZBWW3 (1)	ZBWW3B (1)
	● Red	ZBWW1 (1)	ZBWW1B (1)
	● Yellow	ZBWW1 (1)	ZBWW1B (1)
	● Blue	ZBWW1 (1)	ZBWW1B (1)

(1) If the colour of the lens of the pilot light is GREEN please select the product code ZBWW1 or ZBWW3B depending on the voltage used. For any other colour of lens select the product code ZBWW1 or ZBWW1B

Gaskets between cover and enclosure

Product code	Description
XAWP2 JT	For pendant station with 2 push buttons
XAWP4 JT	For pendant station with 4 push buttons
XAWP6 JT	For pendant station with 6 push buttons
XAWP8 JT	For pendant station with 8 push buttons

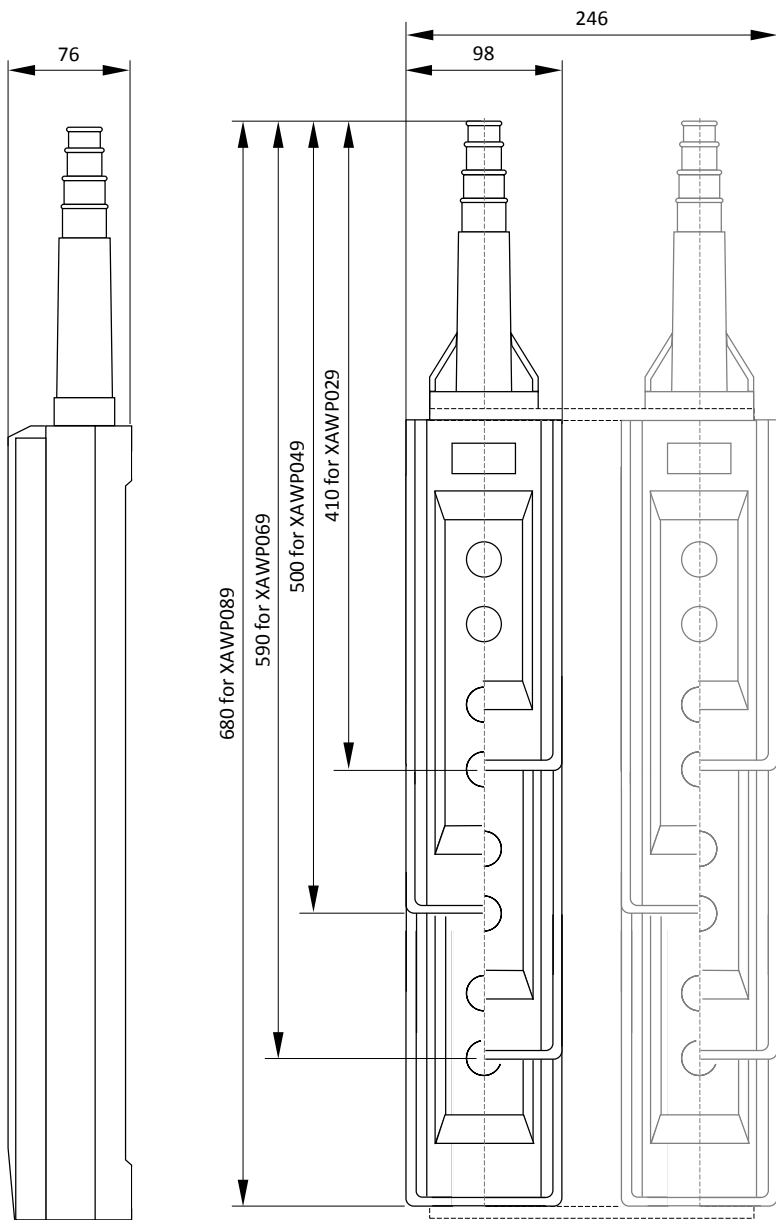



The fire alarm control stations XAWS are an easy way to secure your premises. They are provided with hammer used to break the glass in case of emergency.

The XAWS are available in two operating modes:

- In automatic mode, the contact block is held in position by the glass. The contact opens as soon as the glass is broken.
- In the manual mode, the contact must be operated by the user once the glass is broken.

TECHNICAL DATA

Material	Glass-reinforced polyester (GRP)
IP rating	IP65 according to EN/IEC 60529
Temperature range	-20°C ... +40°C or +50°C or +60°C
Certificate	INERIS 03ATEX0122X
Marking	II 2 GD Ex d e IIC T6 ... T4 Gb T85°C ... T135°C
Features of the contact block	I _{th} = 10 A; U _i = 415 V
	AC U _e = 380 V; I _e = 1,9 A or U _e = 240 V; I _e = 3 A or U _e = 120 V; I _e = 6 A
	DC U _e = 250 V; I _e = 0,27 A or U _e = 125 V; I _e = 0,55 A or U _e = 24 V; I _e = 2,87 A

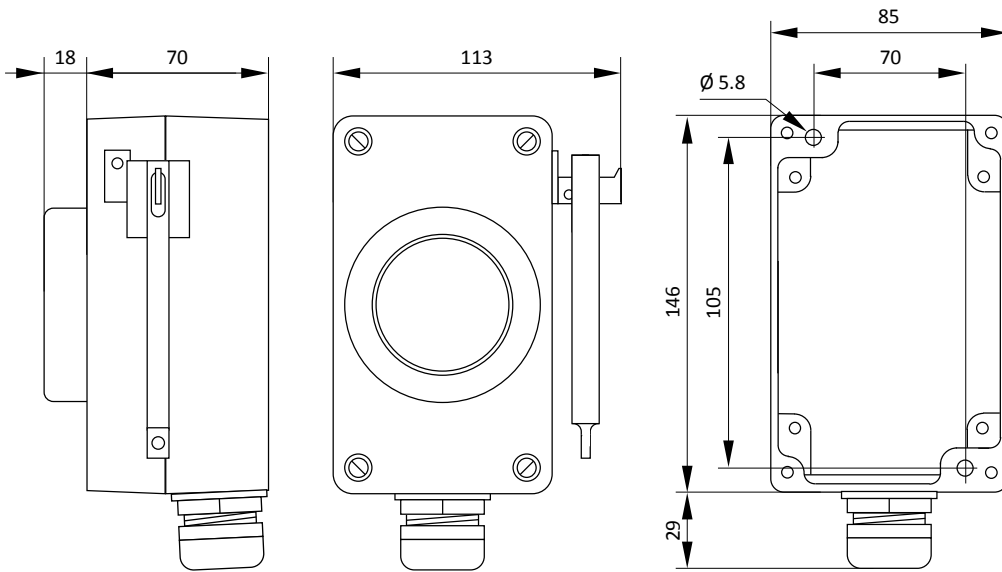

Product code	Control unit type	Contact
XAWS111	Automatic contact operation	1 NC
XAWS121	Automatic contact operation	1 NO
XAWS151	Automatic contact operation	1 NC + 1 NO
XAWS211	Manual contact operation	1 NC
XAWS221	Manual contact operation	1 NO
XAWS251	Manual contact operation	1 NC + 1 NO
Spare part		
XAWS901	Glass	

Additional contact blocks			
Features of the contact block			
Temperature range	-50°C ... +75°C	Electrical features	$I_{th} = 10 \text{ A}; U_i = 415 \text{ V}$
Certificate	INERIS 02ATEX9007U		AC $U_e = 380 \text{ V}; I_e = 1,9 \text{ A}$ or
	IECEX INE 13.0063U		$U_e = 240 \text{ V}; I_e = 3 \text{ A}$ or
Marking	II 2 G		$U_e = 120 \text{ V}; I_e = 6 \text{ A}$
	Ex d e IIC Gb		DC $U_e = 250 \text{ V}; I_e = 0,27 \text{ A}$ or
			$U_e = 125 \text{ V}; I_e = 0,55 \text{ A}$ or
			$U_e = 24 \text{ V}; I_e = 2,87 \text{ A}$

Type	Product code	Description
	ZBWE101	NO
	ZBWE102	NC



Control and signalling units

Content

Page

Push buttons

Push buttons HarmAtex XBW series

40

Emergency stop mushroom push buttons

Emergency stop push buttons HarmAtex XBW series

43

Selector switches

Selector switches XBW

46

Pilot lights

Pilot lights HarmAtex XLW series

50

Illuminated push buttons

Illuminated push buttons HarmAtex series

52

Pull-wire switches

Pull-wire switches XY2WCE series

54

Foot switches

Foot switches XPEWM series

56

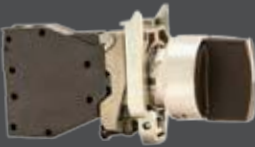

Push buttons

Increased safety - Group IIC XBW series



Our wide HarmAtex range of push buttons and emergency stops combines simplicity of implementation, flexibility and robustness. A system of snap-lock head-body and clamping to the control board by a single screw, ensures an easy and secure mounting.

They equip enclosures or control panels intended for explosive atmospheres gas/vapours or dust in increased safety protection (Ex e) or pressurized (Ex p) or protection by enclosure (Ex t) modes.

Designed to cover the maximum possible uses, each button can be equipped with up to 6 contacts NO or NC.

TECHNICAL DATA

Material	Metal and plastic
IP rating	IP65 or IP 66 according to EN/IEC 60529
Temperature range	-20°C ... +65°C or -20°C ... +75°C
Certificate	INERIS 02ATEX9007U
Marking	II 2 GD Ex d e IIC Gb Ex tb IIIC Db
Number of contact blocks per actuator	Maximum 6 contact blocks
Mounting	Panel cut-out Ø 22,5 mm
Type of terminals	Screw terminals
Features of the contact block	Ith = 10 A; Ui = 415 V AC Ue = 380 V; Ie = 1,9 A or Ue = 240 V; Ie = 3 A or Ue = 120 V; Ie = 6 A DC Ue = 250 V; Ie = 0,27 A or Ue = 125 V; Ie = 0,55 A or Ue = 24 V; Ie = 2,87 A
Mechanical endurance	Head: 5 million operations - Contact block: 1 million operations

Push buttons - Metallic bezel - IP66 - T°: -20°C ... 75°C

Type of actuator Colour Contact Lid mounting

Spring return, flush actuator



- White NC+NO XBW4BA15
- Black NO XBW4BA21
- Black NC+NO XBW4BA25
- Green NO XBW4BA31
- Green NC+NO XBW4BA35
- Red NC XBW4BA42
- Red NC+NO XBW4BA45
- Yellow NC+NO XBW4BA55
- Blue NC+NO XBW4BA65

Spring return, projecting actuator



- White NC+NO XBW4BL15
- Black NO XBW4BL21
- Black NC+NO XBW4BL25
- Green NO XBW4BL31
- Green NC+NO XBW4BL35
- Red NC XBW4BL42
- Red NC+NO XBW4BL45
- Yellow NC+NO XBW4BL55
- Blue NC+NO XBW4BL65

Push buttons - Metallic bezel - IP66 - T°: -20°C ... 75°C

Type of actuator Colour Contact Lid mounting

"Push-push" to release, flush actuator



- White NC+NO XBW4BH015
- Black NO XBW4BH021
- Black NC+NO XBW4BH025
- Green NO XBW4BH031
- Green NC+NO XBW4BH035
- Red NC XBW4BH042
- Red NC+NO XBW4BH045
- Yellow NC+NO XBW4BH055
- Blue NC+NO XBW4BH065

"Push-push" to release, projecting actuator



- White NC+NO XBW4BH15
- Black NO XBW4BH21
- Black NC+NO XBW4BH25
- Green NO XBW4BH31
- Green NC+NO XBW4BH35
- Red NC XBW4BH42
- Yellow NC+NO XBW4BH55
- Blue NC+NO XBW4BH65

Push buttons with silicone boot - Metallic bezel - - IP66 - T°: -20°C ... 75°C

Actuator	Colour	Contact	Lid mounting
 Spring return	○ White	NC+NO	XBW4BP15S
	● Black	NO	XBW4BP21S
	● Black	NC+NO	XBW4BP25S
	● Green	NO	XBW4BP31S
	● Green	NC+NO	XBW4BP35S
	● Red	NC	XBW4BP42S
	● Red	NC+NO	XBW4BP45S
	● Yellow	NC+NO	XBW4BP55S
● Blue	NC+NO	XBW4BP65S	

Mushroom push buttons - Metallic bezel - IP65 - T°: -20°C ... 75°C

Actuator	Colour	Contact	Lid mounting
 Mushroom Ø 40 mm - Spring return	○ White	NC+NO	XBW4BC15
	● Black	NO	XBW4BC21
	● Black	NC+NO	XBW4BC25
	● Green	NO	XBW4BC31
	● Green	NC+NO	XBW4BC35
	● Red	NC	XBW4BC42
	● Red	NC+NO	XBW4BC45
	● Yellow	NC+NO	XBW4BC55
● Blue	NC+NO	XBW4BC65	
Mushroom Ø 40 mm - Push-Pull	● Black	NO	XBW4BT21
Mushroom Ø 40 mm - Push-Pull	● Green	NO	On request
Mushroom Ø 40 mm - With key 455	● Black	NO	XBW4BS121
Mushroom Ø 40 mm - With key 455	● Green	NO	On request
Mushroom Ø 40 mm- Turn to release	● Black	NO	XBW4BS521
Mushroom Ø 40 mm- Turn to release	● Green	NO	On request



Push buttons with silicone boot - Plastic bezel - IP65 - T°: -20°C ... 75°C

Actuator	Colour	Contact	Lid mounting	Base mounting
 Spring return	○ White	NC+NO	XBW5AP15S	XBW5AP15SP
	● Black	NO	XBW5AP21S	XBW5AP21SP
	● Black	NC+NO	XBW5AP25S	XBW5AP25SP
	● Green	NO	XBW5AP31S	XBW5AP31SP
	● Green	NC+NO	XBW5AP35S	XBW5AP35SP
	● Red	NC	XBW5AP42S	XBW5AP42SP
	● Red	NC+NO	XBW5AP45S	XBW5AP45SP
	● Yellow	NC+NO	XBW5AP55S	XBW5AP55SP
● Blue	NC+NO	XBW5AP65S	XBW5AP65SP	



Mushroom push buttons - Plastic bezel - IP65 - T°: -20°C ... 75°C

Actuator	Colour	Contact	Lid mounting	Base mounting
 Mushroom Ø 40 mm - Spring return	○ White	NC+NO	XBW5AC15	XBW5AC15P
	● Black	NO	XBW5AC21	XBW5AC21P
	● Black	NC+NO	XBW5AC25	XBW5AC25P
	● Green	NO	XBW5AC31	XBW5AC31P
	● Green	NC+NO	XBW5AC35	XBW5AC35P
	● Red	NC	XBW5AC42	XBW5AC42P
	● Red	NC+NO	XBW5AC45	XBW5AC45P
	● Yellow	NC+NO	XBW5AC55	XBW5AC55P
● Blue	NC+NO	XBW5AC65	XBW5AC65P	
Mushroom Ø 40 mm - With key 455	● Black	NO	On request	On request
Mushroom Ø 40 mm - With key 455	● Green	NO	On request	On request
Mushroom Ø 40 mm- Turn to release	● Black	NO	On request	On request
Mushroom Ø 40 mm- Turn to release	● Green	NO	On request	On request

Emergency stop mushroom - Snap action - Ø 40 mm - Metallic bezel - IP65 - T°: -20°C ... 65°C

Type of actuator	Colour	Contact	Lid mounting
Push-pull 	● Red	NC	XBW4BT842
	● Red	NC + NO	XBW4BT845
With key 455 	● Red	NC	XBW4BS9442
	● Red	NC + NO	XBW4BS9445
Turn to release 	● Red	NC	XBW4BS8442
	● Red	NC + NO	XBW4BS8445

Emergency stop mushroom - Snap action - Ø 40 mm - Plastic bezel - IP65 - T°: -20°C ... 65°C

Type of actuator	Colour	Contact	Lid mounting	Base mounting
With key 455 	● Red	NC	XBW5AS9442	XBW5AS9442P
	● Red	NC + NO	XBW5AS9445	XBW5AS9445P
Turn to release 	● Red	NC	XBW5AS8442	XBW5AS8442P
	● Red	NC + NO	XBW5AS8445	XBW5AS8445P

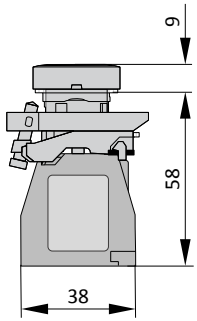

XBW4BA.. or BH..

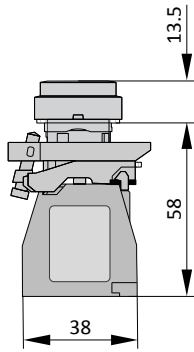

XBW4BA.. or BH0..

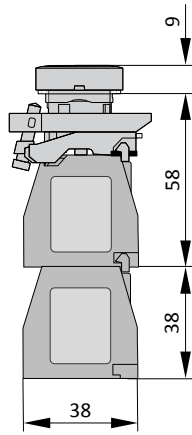

Push button with 2 rows of contacts

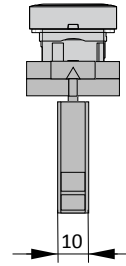

Push button with 1 contact

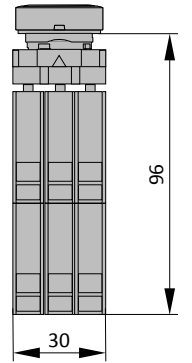

Push button with 2 rows of 3 contacts

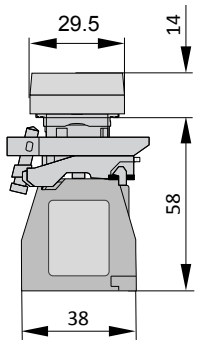

XBW4BP.. or AP..

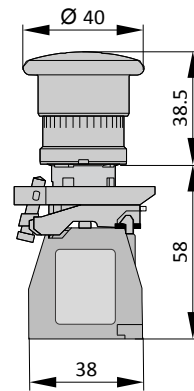

XBW4BC.. or AC... or BT... or BS

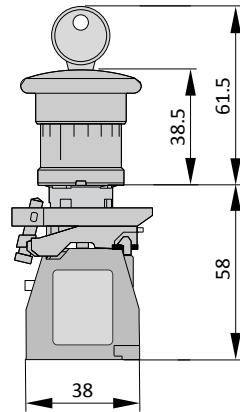

XBW4BS1..

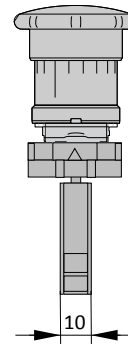

Push button with 1 contact

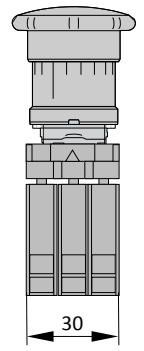

Push button with 1 row of 3 contacts

Additional contact blocks

Features of the contact block

Temperature range	-50°C ... +75°C	Electrical features	I _{th} = 10 A; U _i = 415 V
Certificate	INERIS 02ATEX9007U		AC U _e = 380 V; I _e = 1,9 A or U _e = 240 V; I _e = 3 A or U _e = 120 V; I _e = 6 A
Marking	IECEX INE 13.0063U		DC U _e = 250 V; I _e = 0,27 A or U _e = 125 V; I _e = 0,55 A or U _e = 24 V; I _e = 2,87 A
	II 2 G		
	Ex d e IIC Gb		

Product code	Description	Product code	Description
ZBWE101	NO contact block for lid mounting	ZBWZ101	NO contact with metal fixing device for lid mounting
ZBWE102	NC contact block for lid mounting	ZBWZ102	NC contact with metal fixing device for lid mounting
ZBWE1111	NO contact block for base mounting	ZBWZ1010	NO contact with plastic fixing device for lid mounting
ZBWE1121	NC contact block for base mounting	ZBWZ1020	NC contact with plastic fixing device for mounting on lid



ZBWE101 or 102



ZBWE1111 or 1121



ZBWZ101 or 102



ZBWZ1010 or 1020



Push button with 6 contact blocks

Accessories

Function	Product code	For use with	Colour	Function	Product code	For use with
Metal guard padlockable	ZBZ1604	XBW4BT84 XBW4BS84 XBW4BS94	● Red	Long handle padlockable	On request	2 to 3 positions selector switches. For more information ask to our front line office
Padlockable flap	ZB4BZ62 ZB4B64	All push buttons XBW4BA	● Black ● Red	Blind plug for push button	XAWZ3	Instead of push buttons

Selector switches

Increased safety - Group IIC XBW series



Our wide HarmAtex range of selector switches with standard or long handle or wheel handle or key combines simplicity of implementation, flexibility and robustness. A system of snap-lock head-body and clamping to the control board by a single screw, ensures an easy and secure mounting..



They equip enclosures or control panels intended for explosive atmospheres gas/vapours or dust in increased safety protection (Ex e) or pressurized (Ex p) or protection by enclosure (Ex t) modes.

Designed to cover the maximum possible uses, each button can be equipped with up to 6 contacts NO or NC.

TECHNICAL DATA





Material	Metal and plastic
IP rating	IP65 or IP66 according to EN/IEC 60529
Temperature range	-20°C ... +75°C
Certificate	INERIS 02ATEX9007U
Marking	II 2 GD Ex d e IIC Gb Ex tb IIIC Db
Number of contact blocks per actuator	Maximum 6 contact blocks
Mounting	Panel cut-out Ø 22,5 mm
Type of terminals	Screw terminals
Features of the contact block	Ith = 10 A; Ui = 415 V AC Ue = 380 V; Ie = 1,9 A or Ue = 240 V; Ie = 3 A or Ue = 120 V; Ie = 6 A DC Ue = 250 V; Ie = 0,27 A or Ue = 125 V; Ie = 0,55 A or Ue = 24 V; Ie = 2,87 A
Mechanical endurance	Head: 5 million operations - Contact block: 1 million operations

Selector switches - Metallic bezel - IP66 - T°: -20°C ... 75°C

Type of actuator	Number of positions	Contact	Lid mounting
	2 stay put	NO	XBW4BD21
	2 spring return right and left	NO	XBW4BD41
	3 stay put	• NO + NO	XBW4BD33
	3 spring return to center	• NO + NO	XBW4BD53
	3 spring return from left to center	• NO + NO	XBW4BD73
	3 spring return from right to center	• NO + NO	XBW4BD83
	2 stay put	NO	XBW4BJ21
	2 spring return right and left	NO	XBW4BJ41
	3 stay put	• NO + NO	XBW4BJ33
	3 spring return to center	• NO + NO	XBW4BJ53
	3 spring return from left to center	• NO + NO	XBW4BJ73
	3 spring return from right to center	• NO + NO	XBW4BJ83
	2 stay put	NO	XBW4BD291
	2 spring return right and left	NO	XBW4BD491
	3 stay put	• NO + NO	XBW4BD393
	3 spring return to center	• NO + NO	XBW4BD593
	3 spring return from left to center	• NO + NO	XBW4BD793
	3 spring return from right to center	• NO + NO	XBW4BD893

- This selector switch can have an extra NC contact element on the central position. This contact is actuated on left and right position.

Selector switches - Plastic bezel - IP66 - T°: -20°C ... 75°C

Type of actuator	Number of positions	Contact	Lid mounting	Base mounting
	2 stay put	NO	XBW5AD21	XBW5AD21P
	2 spring return right and left	NO	XBW5AD41	XBW5AD41P
	3 stay put	• NO + NO	XBW5AD33	XBW5AD33P
	3 spring return to center	• NO + NO	XBW5AD53	XBW5AD53P
	3 spring return from left to center	• NO + NO	XBW5AD73	XBW5AD73P
	3 spring return from right to center	• NO + NO	XBW5AD83	XBW5AD83P
	2 stay put	NO	XBW5AJ21	XBW5AJ21P
	2 spring return right and left	NO	XBW5AJ41	XBW5AJ41P
	3 stay put	• NO + NO	XBW5AJ33	XBW5AJ33P
	3 spring return to center	• NO + NO	XBW5AJ53	XBW5AJ53P
	3 spring return from left to center	• NO + NO	XBW5AJ73	XBW5AJ73P
	3 spring return from right to center	• NO + NO	XBW5AJ83	XBW5AJ83P
	2 stay put	NO	XBW5AD291	XBW5AD291P
	2 spring return right and left	NO	XBW5AD491	XBW5AD491P
	3 stay put	• NO + NO	XBW5AD393	XBW5AD393P
	3 spring return to center	• NO + NO	XBW5AD593	XBW5AD593P
	3 spring return from left to center	• NO + NO	XBW5AD793	XBW5AD793P
	3 spring return from right to center	• NO + NO	XBW5AD893	XBW5AD893P
Joystick IP 65	On request			
				

- This selector switch can have an extra NC contact element on the central position. This contact is actuated on left and right position.

Selector switches - Metallic bezel - IP66 - T°: -20°C ... 75°C

Type of actuator	Number of positions	Contact	Lid mounting
 Selector switches with key 455	2 stay put key withdrawal in left position	NO	XBW4BG21
	2 stay put key withdrawal in both position	NO	XBW4BG41
	2 spring return from right to left	• NO	XBW4BG61
	3 stay put, key withdrawal in 3 positions	• NO + NO	XBW4BG03
	3 stay put, key withdrawal in center position	• NO + NO	XBW4BG33
	3 stay put, key withdrawal in left or right position	• NO + NO	XBW4BG53
	3 stay put, key withdrawal in left position	NO + NO	XBW4BG93
	3 stay put, key withdrawal in right position	NO + NO	XBW4BG093
	3 spring return from left to center	• NO + NO	XBW4BG13
	3 spring return to center	• NO + NO	XBW4BG73
	3 spring return from right to center, key withdrawal in center position	• NO + NO	XBW4BG83
	3 spring return from right to center, key withdrawal in left position	• NO + NO	XBW4BG083

- This selector switch can have an extra NC contact element on the central position. This contact is actuated on left and right position.

Selector switches - Plastic bezel - IP65 - T°: -20°C ... 75°C

Type of actuator	Number of positions	Contact	Lid mounting	Base mounting
 Selector switches with key 455	2 stay put key withdrawal in left position	NO	XBW5AG21 (1)	XBW5AG21P (1)
	2 stay put key withdrawal in both position	NO	XBW5AG41 (1)	XBW5AG41P (1)
	2 spring return from right to left	NO	XBW5AG61 (1)	XBW5AG61P (1)
	3 stay put, key withdrawal in 3 positions	• NO + NO	XBW5AG03 (1)	XBW5AG03P (1)
	3 stay put, key withdrawal in center position	• NO + NO	XBW5AG33 (1)	XBW5AG33P (1)
	3 stay put, key withdrawal in left or right position	• NO + NO	XBW5AG53 (1)	XBW5AG53P (1)
	3 stay put, key withdrawal in left position	• NO + NO	XBW5AG93 (1)	XBW5AG93P (1)
	3 stay put, key withdrawal in right position	• NO + NO	XBW5AG093 (1)	XBW5AG093P (1)
	3 spring return from left to center	• NO + NO	XBW5AG13 (1)	XBW5AG13P (1)
	3 spring return to center	• NO + NO	XBW5AG73 (1)	XBW5AG73P (1)
	3 spring return from right to center, key withdrawal in center position	• NO + NO	XBW5AG83 (1)	XBW5AG83P (1)
	3 spring return from right to center, key withdrawal in left position	• NO + NO	XBW5AG083 (1)	XBW5AG083P (1)

- This selector switch can have an extra NC contact element on the central position. This contact is actuated on left and right position.

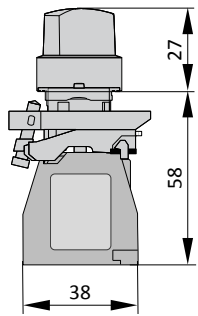

XBW4BD.. or 5AD..

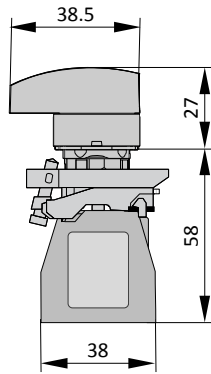

XBW4BJ.. or 5AJ..

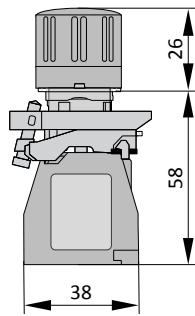

XBW4BD.9. or 5AD.9.

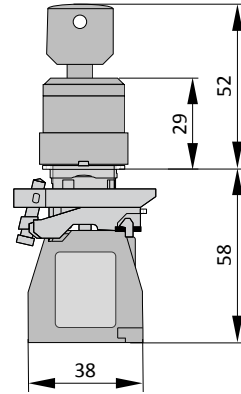

XBW4BG.. or 5AG..

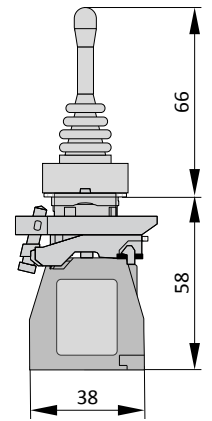

Joystick

Additional contact blocks

Features of the contact block

Temperature range	-50°C ... +75°C	Electrical features	I _{th} = 10 A; U _i = 415 V
Certificate	INERIS 02ATEX9007U		AC U _e = 380 V; I _e = 1,9 A or U _e = 240 V; I _e = 3 A or U _e = 120 V; I _e = 6 A
	IECEX INE 13.0063U		DC U _e = 250 V; I _e = 0,27 A or U _e = 125 V; I _e = 0,55 A or U _e = 24 V; I _e = 2,87 A
Marking	II 2 G		
	Ex d e IIC Gb		

Product code	Description	Product code	Description
ZBWE101	NO contact block for lid mounting	ZBWZ101	NO contact with metal fixing device for lid mounting
ZBWE102	NC contact block for lid mounting	ZBWZ102	NC contact with metal fixing device for lid mounting
ZBWE1111	NO contact block for base mounting	ZBWZ1010	NO contact with plastic fixing device for lid mounting
ZBWE1121	NC contact block for base mounting	ZBWZ1020	NC contact with plastic fixing device for mounting on lid



ZBWE101 or 102



ZBWE1111 or 1121



ZBWZ101 or 102



ZBWZ1010 or 1020



Selector switch with 6 contact blocks



Our range of LED pilot lights HarmAtex in 6 to 24 V AC/DC or 24 to 254 V AC/DC combines simplicity, flexibility and robustness.

A system of snap-lock head-body and clamping to the control board by a single screw, ensures an easy and secure mounting.

With a metal or plastic bezel, they cover the majority of industrial applications in potentially explosive atmospheres gas/vapours or dust in increased safety protection (Ex e) or pressure (Ex p) or protection by enclosure (Ex t) modes.

TECHNICAL DATA

Material	Metal and plastic
IP rating	IP65 according to EN/IEC 60529
Temperature range	-20°C ... +75°C
Certificate	INERIS 04ATEX9003U
Marking	II 2 GD Ex e mb IIC Gb Ex tb IIIC Db
Mounting	Panel cut-out Ø 22,5 mm
Type of terminals	Screw terminals
Rated operational features	Rated voltage 24 ... 254 V AC/DC Maximal current 2 ... 10 ma Or Rated voltage 6 ... 24 V AC/DC Maximal current 14 ... 21 mA
Durability	100 000 hours at ambient temperature

Complete LED Pilot light - 24 to 254 V AC/DC		Metallic bezel		Plastic bezel	
Type	Colour	Lid mounting	Base mounting	Lid mounting	Base mounting
 <p>Lid mounting</p>	○ White	XLW4BV013	-	XLW5AV013	XLW5AV013P
	● Green	XLW4BV033	-	XLW5AV033	XLW5AV033P
	● Red	XLW4BV043	-	XLW5AV043	XLW5AV043P
	● Yellow	XLW4BV053	-	XLW5AV053	XLW5AV053P
	● Blue	XLW4BV063	-	XLW5AV063	XLW5AV063P

Complete LED Pilot light - 6 to 24 V AC/DC		Metallic bezel		Plastic bezel	
Type	Colour	Lid mounting	Base mounting	Lid mounting	Base mounting
 <p>Lid mounting</p>	○ White	XLW4BV013B	-	XLW5AV013B	XLW5AV013PB
	● Green	XLW4BV033B	-	XLW5AV033B	XLW5AV033PB
	● Red	XLW4BV043B	-	XLW5AV043B	XLW5AV043PB
	● Yellow	XLW4BV053B	-	XLW5AV053B	XLW5AV053PB
	● Blue	XLW4BV063B	-	XLW5AV063B	XLW5AV063PB

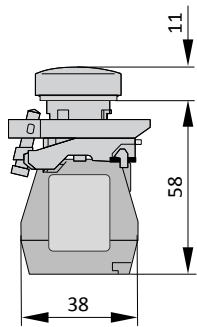

LED Signalling element FOR lid mounting			
Type	Colour	Codes for 24 to 254 V AC/DC	Codes for 6 to 24 V AC/DC
	○ White	ZBWW1 (1)	ZBWW1B (1)
	● Green	ZBWW3 (1)	ZBWW3B (1)
	● Red	ZBWW1 (1)	ZBWW1B (1)
	● Yellow	ZBWW1 (1)	ZBWW1B (1)
	● Blue	ZBWW1 (1)	ZBWW1B (1)

(1) If the colour of the lens of the pilot light is GREEN please select the product code ZBWW1 or ZBWW3B depending on the voltage used. For any other colour of lens select the product code ZBWW1 or ZBWW1B

LED Signalling element FOR base mounting			
Type	Colour	Codes for 24 to 254 V AC/DC	Codes for 6 to 24 V AC/DC
	○ White	ZBWL1 (1)	ZBWL1B (1)
	● Green	ZBWL3 (1)	ZBWL3B (1)
	● Red	ZBWL1 (1)	ZBWL1B (1)
	● Yellow	ZBWL1 (1)	ZBWL1B (1)
	● Blue	ZBWL1 (1)	ZBWL1B (1)

(1) If the colour of the lens of the pilot light is GREEN please select the product code ZBWL1 or ZBWL3B depending on the voltage used. For any other colour of lens select the product code ZBWL1 or ZBWL1B



The illuminated push buttons HarmAtex is very versatile. It combines:

- pilot lights in 6 to 24 V AC/DC or 24 V to 254 V AC/DC
- up to 4 contact blocks can be implemented by push button
- optional silicone boots can be provided

They cover the majority of industrial applications in potentially explosive atmospheres gas/vapours or dust in increased safety protection (Ex e) or pressure (Ex p) or protection by enclosure (Ex t) modes by having the highest level of protection.

TECHNICAL DATA

Material	Metal and plastic
IP rating	IP65 according to EN/IEC 60529
Temperature range	-20°C ... +75°C
Certificate	INERIS 04ATEX9003U, INERIS 02ATEX9007U
Marking	II 2 GD Ex e mb IIC Gb Ex d e mb IIC Gb Ex tb IIIC Db
Number of contact blocks per actuator	Maximum 4 contact blocks
Mounting	Panel cut-out Ø 22,5 mm
Type of terminals	Screw terminals
LED pilot light	Rated voltage 24 V ... 254 V AC/DC Maximal current 2 mA ... 10 mA Or Rated voltage 6 V ... 24 V AC/DC Maximal current 14 mA ... 21 mA
Features of the contact block	I _{th} = 10 A; U _i = 415 V AC U _e = 380 V; I _e = 1,9 A or U _e = 240 V; I _e = 3 A or U _e = 120 V; I _e = 6 A DC U _e = 250 V; I _e = 0,27 A or U _e = 125 V; I _e = 0,55 A or U _e = 24 V; I _e = 2,87 A
Mechanical endurance	Head: 5 million operations - Contact block: 1 million operations

Illuminated push buttons 24 V ... 254 V AC/DC - Metallic bezel

Type of actuator	Colour	Contact	Lid mounting
Illuminated push button, spring return 	○ White	NO	XLW4BP1831
	● Green	NO	XLW4BP3831
	● Red	NC	XLW4BP4832
	● Yellow	NO	XLW4BP5831
	● Blue	NO	XLW4BP6831

Illuminated push buttons 6 V ... 24 V AC/DC - Metallic bezel

Type of actuator	Colour	Contact	Lid mounting
Illuminated push button, spring return 	○ White	NO	XLW4BP1831B
	● Green	NO	XLW4BP3831B
	● Red	NC	XLW4BP4832B
	● Yellow	NO	XLW4BP5831B
	● Blue	NO	XLW4BP6831B

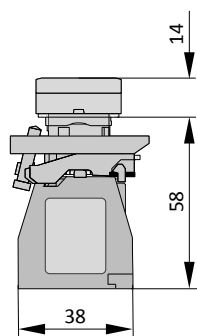
Additional contact blocks
Features of the contact block

Temperature range	-50°C ... +75°C	Electrical features	I _{th} = 10 A; U _i = 415 V
Certificate	INERIS 02ATEX9007U		AC U _e = 380 V; I _e = 1,9 A or U _e = 240 V; I _e = 3 A or U _e = 120 V; I _e = 6 A
Marking	IECEX INE 13.0063U		DC U _e = 250 V; I _e = 0,27 A or U _e = 125 V; I _e = 0,55 A or U _e = 24 V; I _e = 2,87 A
	II 2 G		
	Ex d e IIC Gb		

Type	Product code	Description
	ZBWE101	NO
	ZBWE102	NC

LED Signalling element FOR lid mounting

Type	Colour	Codes for 24 to 254 V AC/DC	Codes for 6 to 24 V AC/DC
	○ White	ZBWW1 (1)	ZBWW1B (1)
	● Green	ZBWW3 (1)	ZBWW3B (1)
	● Red	ZBWW1 (1)	ZBWW1B (1)
	● Yellow	ZBWW1 (1)	ZBWW1B (1)
	● Blue	ZBWW1 (1)	ZBWW1B (1)

(1) If the colour of the lens of the pilot light is GREEN please select the product code ZBWW1 or ZBWW3B depending on the voltage used. For any other colour of lens, select the product code ZBWW1 or ZBWW1B



The pull-wire switches are installed above or near conveyors, machines or installations which can not be secured by other devices such as protective covers.

They provide a reliable and proven solution for all situations where security is fundamental especially in potentially explosive atmospheres.



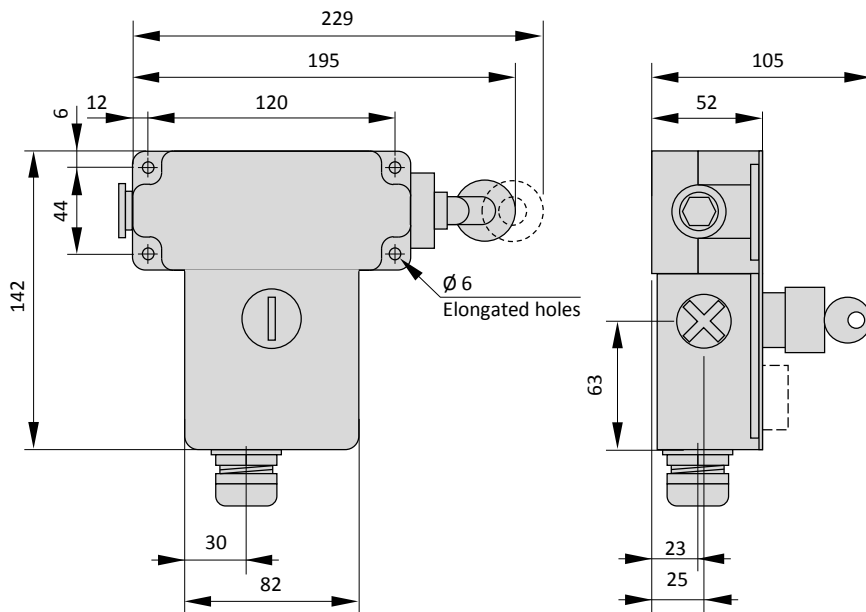

They are designed for explosive atmospheres gas/vapours or dust and meet the highest levels of protection.

TECHNICAL DATA

Material	Zamac, carbon steel
IP rating	IP65 according to EN/IEC 60529
Temperature range	- 20°C ... + 60°C
Certificate	INERIS 04ATEX0040
Marking	II 2 GD Ex d e IIC T6 Gb or Ex tb IIIC T85°C Db
Features of the contact block	U _{max} = 250 V I _{max} = 3 A
Cable entry	M20 cable gland
Mechanical endurance of the head	Head: 5 million operations - Contact block: 1 million operations

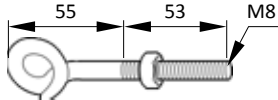
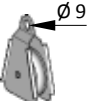

Product code	Control unit type	Operating anchoring cable point	Contact
XY2WCE2A250	Reset by booted push button	To left	1 x NC + NO
XY2WCE2A270	Reset by booted push button	To left	2 x NC + NC
XY2WCE1A250	Reset by booted push button	To right	1 x NC + NO
XY2WCE1A270	Reset by booted push button	To right	2 x NC + NC
XY2WCE2A450	Reset by key release push button - Key 421	To left	1 x NC + NO
XY2WCE2A470	Reset by key release push button - Key 421	To left	2 x NC + NC
XY2WCE1A450	Reset by key release push button - Key 421	To right	1 x NC + NO
XY2WCE1A470	Reset by key release push button - Key 421	To right	2 x NC + NC

Accessories	Product code	Description
	XY2WCZ705	Cable pulley support
	XY2WCZ708	Pulley for Ø 5 mm cable max.
	XY2WCZ701	Cable end protector for cable Ø 3,2 mm
	XY2WCZ704	Cable end protector for cable Ø 5 mm
	XY2WCZ602	Swivelling cable support
	XY2WCZ702	End spring



The foot switch XPEW is a range of foot switches for explosive atmospheres leaving to the operator complete freedom of movement.

They are designed for explosive atmospheres gas/vapours or dust and meet the highest levels of protection.

TECHNICAL DATA

Material	Zamac, carbon steel
IP rating	IP65 according to EN/IEC 60529
Temperature range	- 20°C ... + 60°C
Certificate	INERIS 04ATEX0042
Marking	II 2 GD Ex d e IIC T6 Gb or Ex tb IIIC T85°C Db
Features of the contact block	U _{max} = 250 V I _{max} = 3 A
Cable entry	M20 cable gland
Mechanical endurance	Actuator: 5 million operations - Contact block: 1 million operations

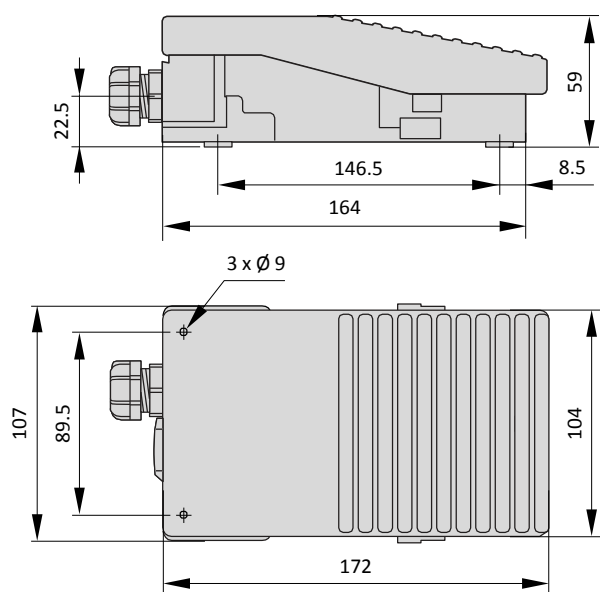

Product code	Control unit type	Colour	Contact
XPEWM110	Contact operation - 1 step	Blue	1 x NC + NO
XPEWM111	Contact operation - 1 step	Blue	2 x NC + NO
XPEWM211	Contact operation - 2 steps	Blue	2 x NC + NO
XPEWR110	Contact operation - 1 step	Orange	1 x NC + NO
XPEWR111	Contact operation - 1 step	Orange	2 x NC + NO
XPEWR211	Contact operation - 2 steps	Orange	2 x NC + NO



Motor Starters - Motor Isolators

Content

Page

Motor starters - Flameproof

Motor starters AC1WD, ERSA, DE8BA series - Explosion gas group IIB

60

Motor starters DE8WH series - Explosion gas group IIC

62

Motor isolators - Increased safety

Polyester and stainless steel motor isolators DE1 series

64



Motor starters

Flameproof - Group IIB Aluminium - AC1WD, DE8BA and ERSA series



The robust range of 3-poles explosion-proof motor starters with thermal relay is ideal for many applications. It is available in three versions:

- with thermal overload relay, without contactor and no fuse
- with thermal overload relay and fuses, without contactor
- with thermal overload relay, contactor and fuses

A wide range of enclosures combined with a wide range of thermal overload relays, contactors, with or without fuses, allows customisation of the motor starters for different applications.

Any individual solution available on request.

TECHNICAL DATA

Material	Cast aluminium for AC1WD and ERSA, cast iron for DE8BA
IP rating	IP65 according to EN/IEC 60529
Temperature range	-20°C ... +40°C or +50°C or +60°C
Certificate	INERIS 03ATEX0145 for AC1DW INERIS 03ATEX144X for DE8BA INERIS 04ATEX0009X for ERSA
Marking	II 2 GD AC1WD Ex d IIB T6 Gb Ex tb IIIC T85°C Db DE8BA Ex d IIB T6 ... T4 Gb Ex tb IIIC T85°C ... 135°C Db ERSA Ex d IIB T6 ... T4 Gb Ex tb IIIC T85°C ... 135°C
Electrical features	AC1WD I _{max} = 65 A; U _{max} = 500 V DE8BA I _{max} = 220 A; U _{max} = 750 V ERSA I _{max} = 500 A; U _{max} = 1000 V
Mechanical endurance of the push buttons	Head: 5 million operations - Contact block: 1 million operations
Surface treatment	Painting RAL 7032 - Other colour on request

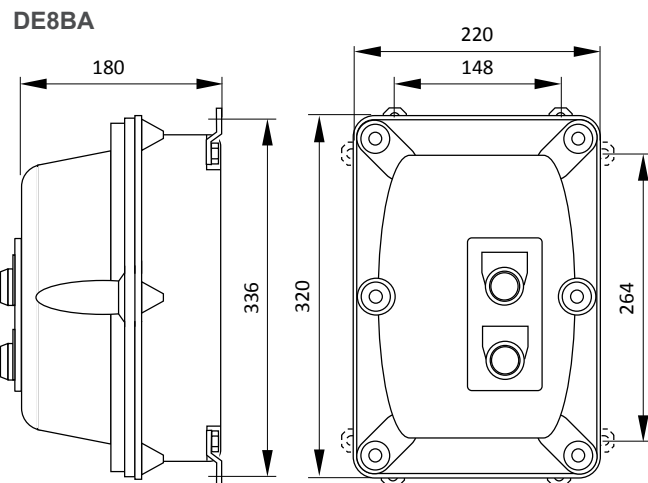
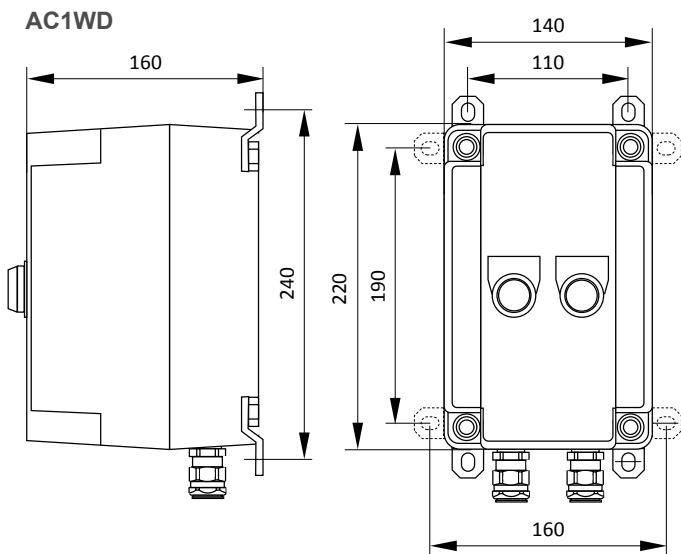

Product code (1) (2)	Rated current A	Motor power			Overload range A	Gas group	T° class	Weight kg
		230 V kW	400 V kW	500 V kW				
AC1WD09 ●● 06	9	-	0.37	0.75	1 ... 1.7	IIB	T6	5.00
AC1WD09 ●● 07	9	0.37	0.75	1.1	1.6 ... 2.5	IIB	T6	5.00
AC1WD09 ●● 08	9	0.75	1.5	2	2.5 ... 4	IIB	T6	5.00
AC1WD09 ●● 10	9	1.1	2.2	3	4 ... 6	IIB	T6	5.00
AC1WD09 ●● 12	9	1.8	3	4	5.5 ... 8	IIB	T6	5.00
AC1WD12 ●● 14	12	2.2	4	5.5	7 ... 10	IIB	T6	5.00
AC1WD18 ●● 16	18	3	5.5	7.5	9 ... 13	IIB	T6	5.00
AC1WD18 ●● 21	18	4	7.5	10	12 ... 18	IIB	T6	6.00
ERSA25 ●● 22	25	5.5	11	15	17 ... 25	IIB	T6	9.00
ERSA32 ●● 32	32	7.5	15	18.5	23 ... 32	IIB	T6	10.00
DE8BA40 ●● 340	40	11	18.5	22	30 ... 40	IIB	T6	26.00
DE8BA65 ●● 350	65	15	22	30	37 ... 50	IIB	T6	26.00
DE8BA65 ●● 365	65	15	25	37	48 ... 65	IIB	T6	26.00

Complete the product code by adding the coil voltage, the number and type of cable entries



Cable entries to add to the basic product code				Codes to add		
Thread	Type of cable	Number of entries	Position			
		2	1 on top + 1 on bottom	P1		
		2	2 on bottom	P2		
		3	1 on top + 2 on bottom	P3		
M20	1F for unarmoured cable with clamping module			1	I	C
	4F for armoured cable			4	I	
	Without cable entry			5	I	
M25	1F for unarmoured cable with clamping module			6	I	C
	4F for armoured cable			8	I	
	Without cable entry			9	I	
M32 (3)	1F for unarmoured cable with clamping module			31	I	C
	4F for armoured cable			34	I	
	Without cable entry			35	I	

1) The triple-pole starters Ex d with overload relay without isolator, without fuse. Includes Start and Stop push buttons.

2) In the product code the ●● has to be replaced by one of the following coil voltage code:

P7 for 230V AC

Q7 for 380V AC

V7 for 400 V AC

Example: **AC1WD09 ●● 07** with a coil voltage of 230V AC and 2 x M25 1F cable glands on the positions A,H becomes **AC1WD09P707P16IC**

3) For product codes DE8BA with a rated current of 65A.



The robust range of 3-poles explosion-proof motor starters with thermal relay is ideal for many applications. It is available in three versions:

- with thermal overload relay, without contactor and no fuse
- with thermal overload relay and fuses, without contactor
- with thermal overload relay, contactor and fuses

A wide range of enclosures combined with a wide range of thermal overload relays, contactors, with or without fuses, allows customisation of the motor starters for different applications. They meet the highest levels of protection.

Any individual solution available on request.

TECHNICAL DATA

Material	Aluminium
IP rating	IP65 according to EN/IEC 60529
Temperature range	-20°C ... +40°C or +50°C or +60°C
Certificate	IINERIS 03ATEX0121X
Marking	II 2 GD Ex d IIC T6 ... T4 Gb
Electrical features	I _{max} = 65 A; U _{max} = 500 V AC
Mechanical endurance of the push buttons	Head: 5 million operations - Contact block: 1 million operations
Surface treatment	Painting RAL 7032 - Other colour on request

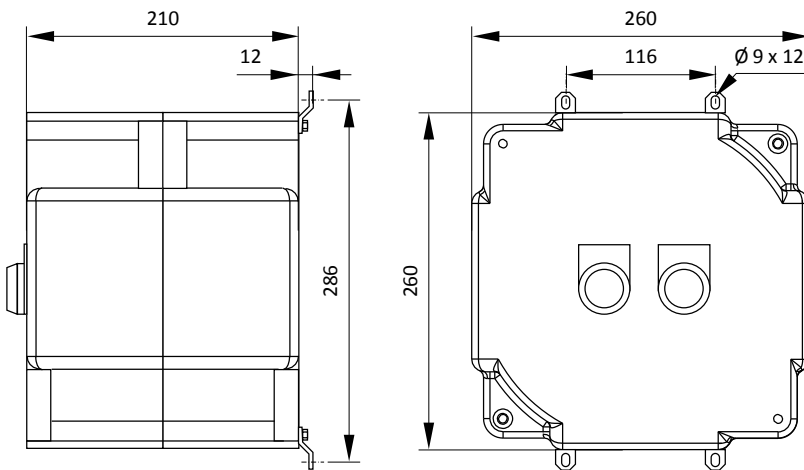

Product code (1) (2)	Rated current A	Motor power			Overload range A	Gas group	T° class	Weight kg
		230 V kW	400 V kW	500 V kW				
DE8WH09 ●● 06	9	-	0.37	0.75	1 ... 1.7	IIC	T3	12,00
DE8WH09 ●● 07	9	0.37	0.75	1.1	1.6 ... 2.5	IIC	T3	12,00
DE8WH09 ●● 08	9	0.75	1.5	2	2.5 ... 4	IIC	T3	12,00
DE8WH09 ●● 10	9	1.1	2.2	3	4 ... 6	IIC	T3	12,00
DE8WH09 ●● 12	9	1.8	3	4	5.5 ... 8	IIC	T3	12,00
DE8WH12 ●● 14	12	2.2	4	5.5	7 ... 10	IIC	T3	12,00
DE8WH18 ●● 16	18	3	5.5	7.5	9 ... 13	IIC	T3	12,00
DE8WH18 ●● 21	18	4	7.5	10	12 ... 18	IIC	T3	12,00
DE8WH25 ●● 22	25	5.5	11	15	17 ... 25	IIC	T3	12,00
DE8WH32 ●● 32	32	7.5	15	18.5	23 ... 32	IIC	T3	12,00
DE8WH40 ●● 340	40	11	18.5	22	30 ... 40	IIC	T3	12,00
DE8WH65 ●● 350	65	15	22	30	37 ... 50	IIC	T3	12,00
DE8WH65 ●● 365	65	15	25	37	48 ... 65	IIC	T3	12,00

Complete the product code by adding the coil voltage, the number and type of cable entries



Cable entries to add to the basic product code				Codes to add		
Thread	Type of cable	Number of entries	Position	P1	P2	P3
		2	1 on top + 1 on bottom			
		2	2 on bottom			
		3	1 on top + 2 on bottom			
M20	1F for unarmoured cable with clamping module			1	I	
	4F for armoured cable			4	I	C
	Without cable entry			5	I	
M25	1F for unarmoured cable with clamping module			6	I	
	4F for armoured cable			8	I	C
	Without cable entry			9	I	
M32 (3)	1F for unarmoured cable with clamping module			31	I	
	4F for armoured cable			34	I	C
	Without cable entry			35	I	

1) The triple-pole starters Ex d with overload relay without isolator, without fuse. Includes Start and Stop push buttons.

2) In the product code the ●● has to be replaced by one of the following coil voltage code:

- P7** for 230V AC
- Q7** for 380V AC
- V7** for 400 V AC

Example: **DE8WH09 ●● 07** with a coil voltage of 230V AC and 2 x M25 1F cable glands on the positions A,H becomes **DE8WH09P707P16IC**

3) For product codes DE8WH with a rated current of 65A.

Safety switches

Increased safety - Group IIC DE1 series



The safety switches are made of polyester (GRP) or stainless steel AISI 316L.

They provide isolation during maintenance or repair of machines in every industrial application in hazardous areas.

TECHNICAL DATA

Material	GRP or Stainless steel AISI 316L						
IP rating	IP66 according to EN/IEC 60529						
Temperature range	-20°C/-50°C ... +40°C/+60°C						
Certificate	INERIS						
Marking	II 2 GD Ex d e IIC T4/T5 Gb Ex tb IIIC T80°C Db IP66						
Polarity	2P or 3/4 poles						
Electrical features	Category AC22A	Rated current	20A	25A	32A	40A	63A
		Rated voltage	690V	690V	690V	690V	690V
	Category AC23A	Rated current	20A	25A	32A	40A	63A
	Rated voltage	-	-	-	690V	690V	
		Rated voltage	500V	500V	500V	500V	500V
	Category AC3	Rated current	20A	25A	32A	40A	63A
		Rated voltage	500V	500V	500V	-	-
Accessories on request	Earth-stud Breath valves Auxiliary contacts Ambient temperature of -50°C ... +55°C or +60°C						

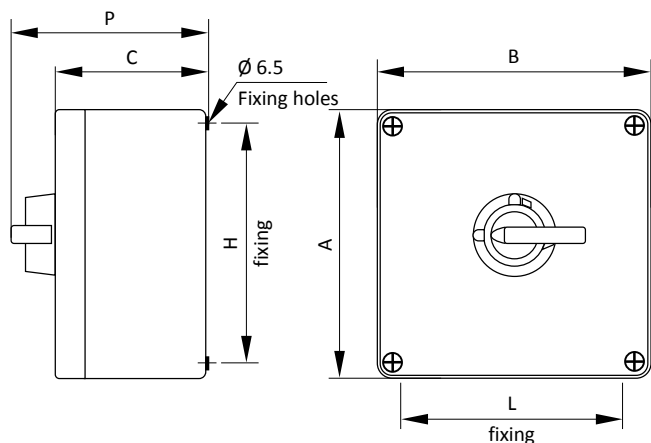

Enclosure in GRP

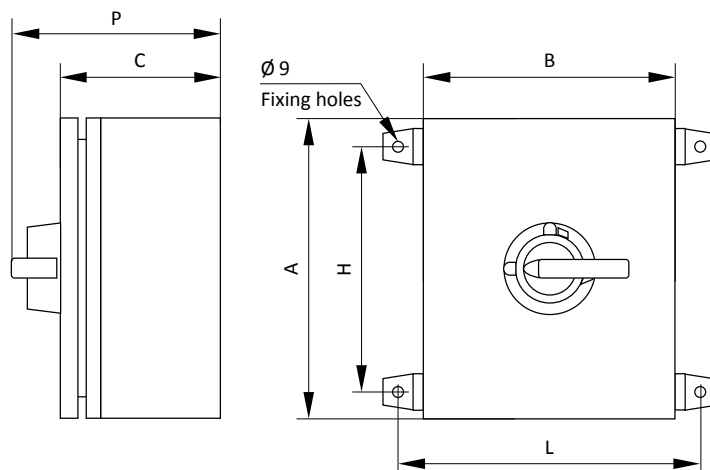

Enclosure in stainless steel

Enclosure in glass-reinforced polyester (GRP)

General use (1)	Emergency use (2)	Number poles	Rated current	Cable entries	Dimensions					T° Gas (3) -20°C...60°C	T° Dust -20°C...60°C
					A	B	C	P	H x L		
DE1GU202	DE1EU202	2P	20A	2 x M25	160	160	91	125	110 x 140	T4	T80°C
DE1GU204	DE1EU204	3/4P	20A	2 x M25	160	160	91	125	110 x 140	T4	T80°C
DE1GU252	DE1EU252	2P	25A	2 x M25	160	160	91	125	110 x 140	T4	T80°C
DE1GU254	DE1EU254	3/4P	25A	2 x M25	160	160	91	125	110 x 140	T4	T80°C
DE1GU322	DE1EU322	2P	32A	2 x M25	160	160	91	125	110 x 140	T4	T80°C
DE1GU324	DE1EU324	3/4P	32A	2 x M32	160	160	91	125	110 x 140	T4	T80°C
DE1GU402	DE1EU402	2P	40A	2 x M32	250	255	121	155	200 x 235	T4	T80°C
DE1GU404	DE1EU404	3/4P	40A	2 x M40	250	255	121	155	200 x 235	T4	T80°C
DE1GU632	DE1EU632	2P	63A	2 x M40	250	255	121	155	200 x 235	T4	T80°C
DE1GU634	DE1EU634	3/4P	63A	2 x M50	250	255	121	155	200 x 235	T4	T80°C

- 1) The colour of the handle switch is black
- 2) The colour of the handle switch is red and yellow
- 3) Temperature class T5 with an ambient temperature of +40°C or +50°C

Enclosure in stainless steel AISI 316L

General use (1)	Emergency use (2)	Number poles	Rated current	Cable entries	Dimensions					T° Gas (3) -20°C...60°C	T° Dust -20°C...60°C
					A	B	C	P	H x L		
SDE1GU202	SDE1EU202	2P	20A	2 x M25	200	150	150	185	150 x 200	T4	T80°C
SDE1GU204	SDE1EU204	3/4P	20A	2 x M25	200	150	150	185	150 x 200	T4	T80°C
SDE1GU252	SDE1EU252	2P	25A	2 x M25	200	150	150	185	150 x 200	T4	T80°C
SDE1GU254	SDE1EU254	3/4P	25A	2 x M25	200	150	150	185	150 x 200	T4	T80°C
SDE1GU322	SDE1EU322	2P	32A	2 x M25	200	150	150	185	150 x 200	T4	T80°C
SDE1GU324	SDE1EU324	3/4P	32A	2 x M32	200	150	150	185	150 x 200	T4	T80°C
SDE1GU402	SDE1EU402	2P	40A	2 x M32	300	200	150	185	250 x 250	T4	T80°C
SDE1GU404	SDE1EU404	3/4P	40A	2 x M40	300	200	150	185	250 x 250	T4	T80°C
SDE1GU632	SDE1EU632	2P	63A	2 x M40	300	200	150	185	250 x 250	T4	T80°C
SDE1GU634	SDE1EU634	3/4P	63A	2 x M50	300	200	150	185	250 x 250	T4	T80°C

- 1) The colour of the handle switch is black
- 2) The colour of the handle switch is red and yellow
- 3) Temperature class T5 with an ambient temperature of +40°C or +50°C

Accessories

Product code	Description	Product code	Description
DE1VE	Breather valve	ZBWE101 (4)	Auxiliary contact NO - Max. 2 contacts
DE1TT	Earth-stud	ZBWE102 (4)	Auxiliary contact NC - Max. 2 contacts

(4) The contacts NO and NC can be mixed to fit 1NO + 1NC



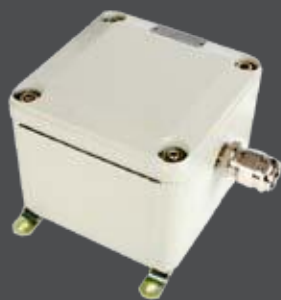
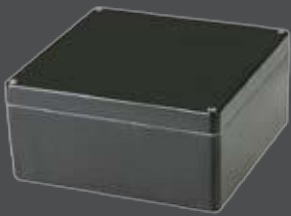

Junction boxes

Content

Page

Increased safety

XAWG series in glass-reinforced polyester

68

XAWF series in aluminium

70

DE1WG series in carbon steel and stainless steel

72

TNAE series in stainless steel

74

Flameproof - Explosion gas group IIB and IIC

DE8BA and XADW series - Explosion gas group IIB

76

XAEW series - Explosion gas group IIC

76

ERSA series - Large junction boxes - Explosion gas group IIB

78



The junction boxes XAWG made in glass-reinforced polyester (GRP), are ideal for environments in the presence of chemical agents, corrosion resistant and suitable for very high and very low ambient temperatures.

The maximum number of terminals depends on the terminal section, the ambient temperature and the required temperature class.

On request, they can also be equipped with push buttons, selector switches, pilot lights, measurement instruments and are available in other sizes.

TECHNICAL DATA

Material	Glass-reinforced polyester loaded with carbon black for antistatic protection
IP rating	IP66 according to EN/IEC 60529
Temperature range	-50°C ... +60°C
Certificate	INERIS 03ATEX0122X
Marking	II 2 GD Ex e IIC T6 ... T5 Gb Ex tb IIIC Db T85°C ... T100°C
Surface treatment	Finishing natural black RAL 9005
Accessories on request	External hinges in thermoplastic Drain and breather valves Fixing bracket in stainless steel AISI 316L Earth continuity plate, internal, in zinc plated brass or copper Earth stud in brass or stainless steel Cable glands

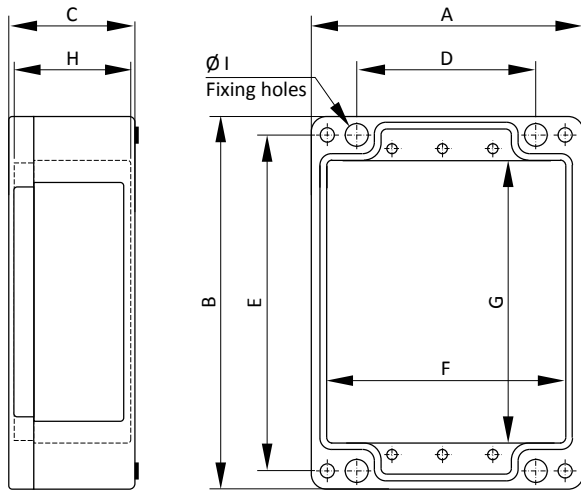

Dimensions

Product code	External			Internal			Fixing holes		Weight kg
	A	B	C	F	G	P	D	E	
XAWG0809	75	80	75	58	48	66	45	68	0.31
XAWG0812	75	110	75	58	78	66	45	98	0.39
XAWG0817	75	160	75	58	128	66	45	148	0.51
XAWG0820	75	190	75	58	158	66	45	178	0.56
XAWG0824	75	230	75	58	198	66	39	218	0.69
XAWG1212	120	122	90	102	104	80	82	106	0.78
XAWG1222	120	220	90	102	190	80	82	204	1.07
XAWG1616	160	160	90	142	112	80	110	140	1.20
XAWG1626	160	260	90	142	212	80	110	240	1.65
XAWG1636	160	360	90	142	312	80	110	340	2.05
XAWG1656	160	560	90	142	512	80	110	540	3.07
XAWG2526	250	255	120	230	235	110	200	235	2.56
XAWG2540	250	400	120	230	380	110	200	380	3.59
XAWG2560	250	600	120	230	580	110	200	560	5.24
XAWG4140	405	400	165	385	380	154	355	380	5.82

Number maximum of entries per side

Product code	Size A x B x C	Maximum of entries on the long sides								Maximum of entries on the short sides							
		M12	M16	M20	M25	M32	M40	M50	M63	M12	M16	M20	M25	M32	M40	M50	M63
XAWG0809	75 x 80 x 75	4	2	1	1	-	-	-	-	2	2	-	-	-	-	-	-
XAWG0812	75 x 110 x 75	6	6	3	2	1	-	-	-	2	2	-	-	-	-	-	-
XAWG0817	75 x 160 x 75	10	10	5	3	2	-	-	-	2	2	-	-	-	-	-	-
XAWG0820	75 x 190 x 75	14	12	6	4	3	-	-	-	2	2	-	-	-	-	-	-
XAWG0824	75 x 230 x 75	16	12	6	4	2	-	-	-	2	2	-	-	-	-	-	-
XAWG1212	120 x 122 x 90	6	5	2	1	1	-	-	-	5	5	4	1	1	-	-	-
XAWG1222	120 x 220 x 90	14	14	9	4	3	-	-	-	5	4	2	1	1	-	-	-
XAWG1616	160 x 160 x 90	12	8	6	3	2	1	-	-	6	6	4	2	1	-	-	-
XAWG1626	160 x 260 x 90	26	16	12	6	4	3	-	-	6	6	4	2	1	-	-	-
XAWG1636	160 x 360 x 90	38	22	18	9	6	4	-	-	6	6	4	2	1	-	-	-
XAWG1656	160 x 560 x 90	58	36	28	14	8	6	-	-	6	6	4	2	1	-	-	-
XAWG2526	250 x 255 x 120	24	18	10	8	4	3	2	2	21	15	8	6	3	2	2	1
XAWG2540	250 x 400 x 120	42	33	18	16	6	5	4	3	21	15	8	6	3	2	2	1
XAWG4140	405 x 400 x 165	70	44	27	21	12	10	4	3	65	40	24	21	10	10	4	3



The junction boxes XAWF made in aluminium are ideal for environments in the presence of chemical agents, corrosion resistant and suitable for very high and very low ambient temperatures.

The maximum number of terminals depends on the terminal section, the ambient temperature and the required temperature class.

On request, they can also be equipped with push buttons, selector switches, pilot lights, measurement instruments and are available in other sizes.

TECHNICAL DATA

Material	Aluminium
IP rating	IP66 according to EN/IEC 60529
Temperature range	-50°C ... +60°C
Certificate	INERIS 03ATEX0122X
Marking	II 2 GD Ex e IIC T6 ... T4 Gb Ex tb IIIC T85°C ... T135°C Db
Surface treatment	Painting black RAL 9005
Accessories on request	External hinges in thermoplastic Drain and breather valves Fixing bracket in stainless steel AISI 316L Earth continuity plate, internal, in zinc plated brass or copper Earth stud in brass or stainless steel Cable glands

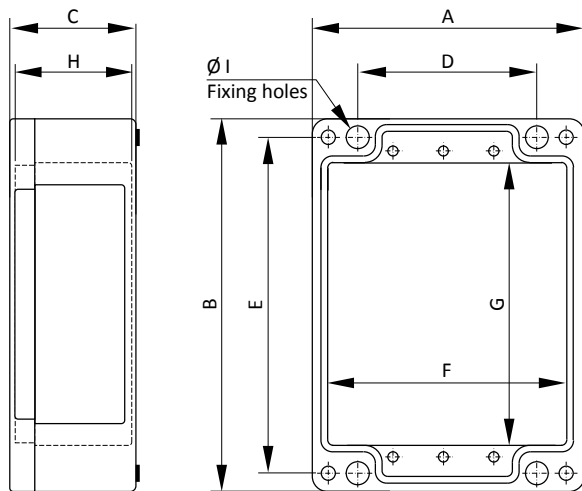

Dimensions

Product code	External			Internal			Fixing holes		Dissipated power	Weight
	A	B	C	F	G	P	D	E	W	kg
XAWF080807	80	80	76	47	71	58	50	65	8	0.32
XAWF081707	80	175	76	71	147	58	50	160	30	0.60
XAWF082505	80	250	76	71	232	58	50	205	40	1.10
XAWF121209	120	122	81	109	88	72	82	106	12	0.92
XAWF122209	120	220	91	109	186	72	82	204	30	1.41
XAWF162609	160	260	90	148	218	72	110	240	40	2.01
XAWF163609	160	360	90	148	318	72	110	340	60	2.52
XAWF165609	160	560	90	148	518	72	110	540	100	3.74
XAWF232011	230	200	110	217	157	92	180	180	53	2.42
XAWF233318	230	330	180	217	287	160	180	310	103	5.24
XAWF234011	230	400	110	217	357	92	180	380	130	3.82
XAWF314014	310	400	140	296	359	129	262	382.5	130	6.70
XAWF316018	310	600	180	296	559	158	260	580	210	11.08

Number maximum of entries per side

Product code	Size A x B x C	Maximum of entries on sides A								Maximum of entries on the sides B							
		M12	M16	M20	M25	M32	M40	M50	M63	M12	M16	M20	M25	M32	M40	M50	M63
XAWF080807	80 x 80 x 76	2	2	2	1	1	-	-	-	2	2	2	1	1	-	-	-
XAWF081707	80 x 175 x 76	2	2	2	2	1	-	-	-	3	3	3	3	3	-	-	-
XAWF082505	80 x 250 x 76	2	2	2	2	1	-	-	-	5	5	5	5	3	-	-	-
XAWF121209	120 x 122 x 81	3	3	2	1	-	-	-	-	7	12	6	6	3	1	1	-
XAWF122209	120 x 220 x 91	3	3	2	1	-	-	-	-	12	24	12	12	6	3	2	-
XAWF162609	160 x 260 x 90	4	3	2	1	-	-	-	-	27	30	16	16	12	5	4	3
XAWF163609	160 x 360 x 90	4	3	2	1	-	-	-	-	36	42	32	22	18	8	6	5
XAWF165609	160 x 560 x 90	4	3	2	1	-	-	-	-	54	78	40	36	28	12	8	6
XAWF232011	230 x 200 x 110	15	10	6	4	3	2	-	-	84	28	18	18	8	6	3	2
XAWF233318	230 x 330 x 118	16	10	6	4	3	2	-	-	80	56	36	20	18	12	6	4
XAWF234011	230 x 400 x 110	16	10	6	4	3	2	-	-	100	68	42	35	20	16	8	6
XAWF314014	310 x 400 x 140	20	12	8	8	4	2	-	-	100	68	42	35	20	16	8	6
XAWF316018	310 x 600 x 180	20	12	10	8	4	3	-	-	150	104	54	54	28	16	10	8

Junction boxes

Increased safety - Group IIC - Painted steel or stainless steel AISI 316L- DE1GW series



The junction boxes DE1GW are ideal for environments in the presence of chemical agents, corrosion resistant and suitable for very high and very low ambient temperatures.

The maximum number of terminals depends of terminals section, operating temperature and required temperature class. They are equipped with a mounting plate and the fixing brackets.

They can also be equipped with push buttons, selector switches, pilot lights, measurement instruments and are available in other sizes.

TECHNICAL DATA

Material	Carbon steel painted or stainless steel AISI 316L
IP rating	IP65/66 according to EN/IEC 60529
Temperature range	-40°C ... +60°C (T4) -40°C ... +50°C (T5) -40°C ... +40°C (T6)
Certificate	INERIS 03ATEX0006
Marking	II 2 GD Ex e IIC T6 ... T4 Gb Ex tb IIIC T85°C ... T135°C Db
Surface treatment	Carbon steel: painting RAL 7035, other colour on request Stainless steel: bead blasting as standard or as option electropolished
Accessories on request	External hinges Breather valves Earth stud in brass or stainless steel Cover locking facilities Gland plates Cable glands

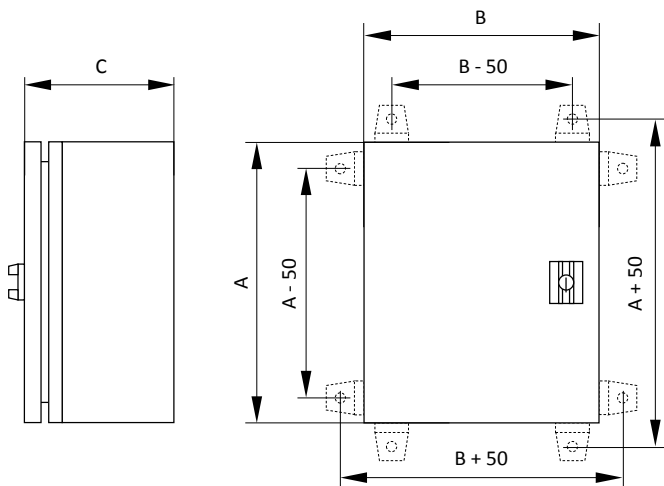

Dimensions

Product codes carbon steel	Product codes stainless steel	External			Fixing See drawing	Max. dissipated power at Tamb = 40°C (W)	Volume (dm ³)	Weight (kg)
		A	B	C				
DE1GW302020	DE1GWS302020	200	300	200	"	30 W	12	5
DE1GW302515	DE1GWS302515	250	300	150	"	30 W	11	5.15
DE1GW282820	DE1GWS282820	280	280	200	"	40 W	15	7
DE1GW403020	DE1GWS403020	300	400	200	"	50 W	24	8.6
DE1GW383820	DE1GWS383820	380	380	200	"	50 W	29	9.3
DE1GW385720	DE1GWS385720	570	380	200	"	65 W	43	11.2
DE1GW504025	DE1GWS504025	400	500	250	"	90 W	50	14.1
DE1GW575720	DE1GWS575720	570	570	200	"	105 W	65	17.9
DE1GW577627	DE1GWS577627	760	570	270	"	140 W	117	23.9
DE1GW706030	DE1GWS706030	600	700	300	"	180 W	126	26.1
DE1GW907030	DE1GWS907030	700	900	300	"	240 W	189	49.8
DE1GW769527	DE1GWS769527	950	760	270	"	240 W	195	36.7

Other sizes available on request

Number maximum of entries per side

Product code	M16	M18	M20	M25	M32	M40	M50	M63
DE1GW302020	10	10	10	8	5	3	2	-
DE1GW302515	10	10	10	8	5	3	2	-
DE1GW282820	10	10	10	8	5	3	2	-
DE1GW403020	28	24	24	18	15	8	6	2
DE1GW383820	28	24	24	18	15	8	6	2
DE1GW385720	66	50	50	45	28	18	15	6
DE1GW504025	66	50	50	45	28	18	15	6
DE1GW575720	66	50	50	45	28	18	15	6
DE1GW577627	152	112	112	75	60	40	24	15
DE1GW706030	152	112	112	75	60	40	24	15
DE1GW907030	184	133	133	90	75	48	30	21
DE1GW769527	184	133	133	90	75	48	30	21



The junction boxes TNAE, made in stainless steel AISI 316L, are dedicated to hazardous areas and ideally suited to environments in the presence of chemical agents, seawater resistant for very high and very low operating temperatures.

The maximum number of terminals depends on the terminal section, the ambient temperature and the required temperature class.

TECHNICAL DATA

Material	Stainless steel AISI 316L
IP rating	IP66/IP67 (IP68 on request) according to EN/IEC 60529
Temperature range	-40°C ... +60°C (T4) -40°C ... +40°C (T5) Option: -50°C ... +60°C
Certificate	DNV 10ATEX90171
Marking	II 2 GD Ex e II T5 ... T4 Gb Ex tD A21 T85°C ... T100°C
Surface treatment	Acid as standard
Accessories upon on request	Breather valves Mounting plate Earth continuity plate, internal, Earth stud Gland plates Cable glands Electropolished treatment

TNAE 121009 and 151510

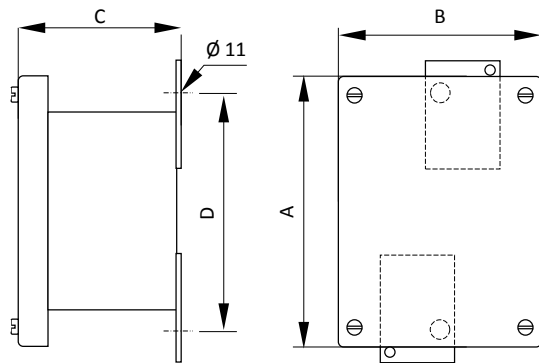

TNAE from 202010

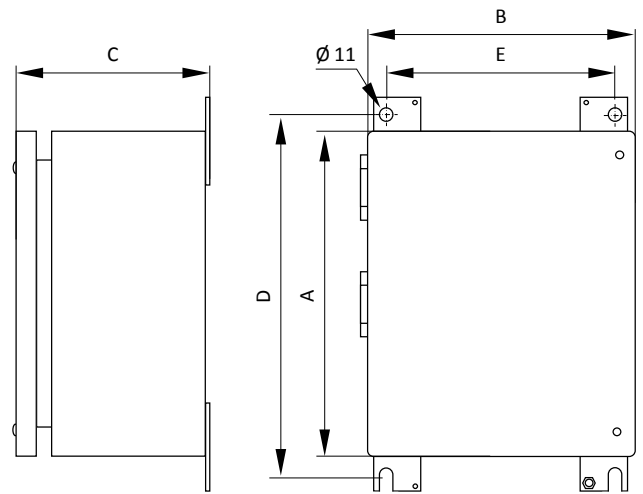

Dimensions

Product code	External			Fixing holes		Max. dissipated power at Tamb = 40°C (W)	Volume (dm ³)	Weight (kg)
	A	B	C	D	E			
TNAE121009	160	120	90	150	-	6 W	1.08	1.5
TNAE151510	187	176	100	180	-	15 W	2.25	2.5
TNAE202010	200	200	100	230	160	20 W	4.00	3.0
TNAE202015	200	200	170	230	160	20 W	6.00	3.5
TNAE282815	280	280	170	310	240	30 W	11.76	5.2
TNAE302015	200	300	170	230	260	30 W	9.00	5.0
TNAE383815	380	380	170	410	340	40 W	21.66	8.1
TNAE384515	450	380	170	480	340	50 W	25.65	8.9
TNAE385715	570	380	170	600	340	65 W	32.49	10.7
TNAE575715	570	570	170	600	530	90 W	48.74	16.4
TNAE575730	570	570	320	600	530	90 W	97.47	21.4
TNAE577620	760	570	220	790	530	120 W	86.64	21.7
TNAE769520	950	760	220	980	720	200 W	144.40	32.9

Other sizes available on request

Number maximum of entries per side

Product code	M20 - 1/2"		M25 - 3/4"		M32 - 1"		M40 - 1" 1/4		M50 - 1" 1/2		M63 - 2"	
	A (1)	B (1)	A (1)	B (1)	A (1)	B (1)	A (1)	B (1)	A (1)	B (1)	A (1)	B (1)
TNAE121009	6	4	4	2	3	2	2	1	2	1	1	1
TNAE151510	6	6	4	4	3	3	2	2	2	2	1	1
TNAE202010	10	10	7	7	4	4	2	2	2	2	2	2
TNAE202015	12	12	8	8	6	6	5	5	4	4	3	3
TNAE282815	18	18	12	12	9	9	8	8	7	7	4	4
TNAE302015	21	12	14	8	10	6	9	5	8	4	5	3
TNAE383815	24	24	16	16	12	12	10	10	9	9	6	6
TNAE384515	30	24	20	16	15	12	13	10	12	9	7	6
TNAE385715	39	24	26	16	19	12	17	10	15	9	9	6
TNAE575715	39	39	26	26	19	19	17	17	15	15	9	9
TNAE575730	88	88	58	58	44	44	39	39	35	35	22	22
TNAE577620	68	52	45	34	34	26	30	23	27	20	17	13
TNAE769520	88	68	58	45	44	34	39	30	35	27	22	17

(1) A: on the long sides - B: on the short sides



The highly robust flameproof junction boxes DE8BA, XAWD and XAEW are designed for use in every industrial environments and can be used in the highest restrictive hazardous areas.

The maximum number of terminals depends of terminals section, operating temperature and required temperature class. They can also be equipped with push buttons, selector switches, pilot lights, measurement instruments.

TECHNICAL DATA

Material	DE8BA: Cast iron XADW: Aluminium XAEW: Aluminium
IP rating	IP65/66 according to EN/IEC 60529
Temperature range	-20°C ... +40°C or 60°C
Certificate	DE8BA: INERIS 03ATEX0144X XADW: INERIS 03ATEX0145 XAEW: INERIS 03ATEX0146
Marking	II 2 GD DE8BA Ex d IIB T6 ... T4 Gb Ex tb IIIC T85°C ... T135°C Db Ex d [ia] IIB T6 Gb Ex tb IIIC T85°C Db XADW Ex d IIB T6 Gb Ex tb IIIC T85°C Db XAEW Ex d IIC T6 Gb Ex tb IIIC T85°C Db
Surface treatment	Painting RAL 7032
Accessories upon on request	Breather valves Internal and external earth stud Cable glands

DE8BA

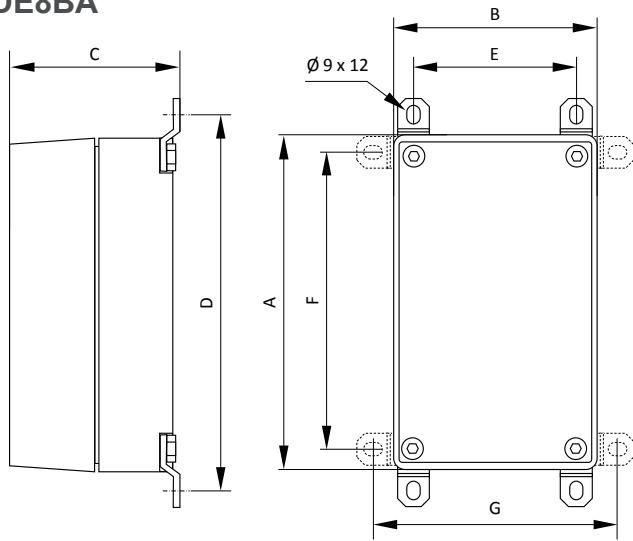

XADW, XAEW

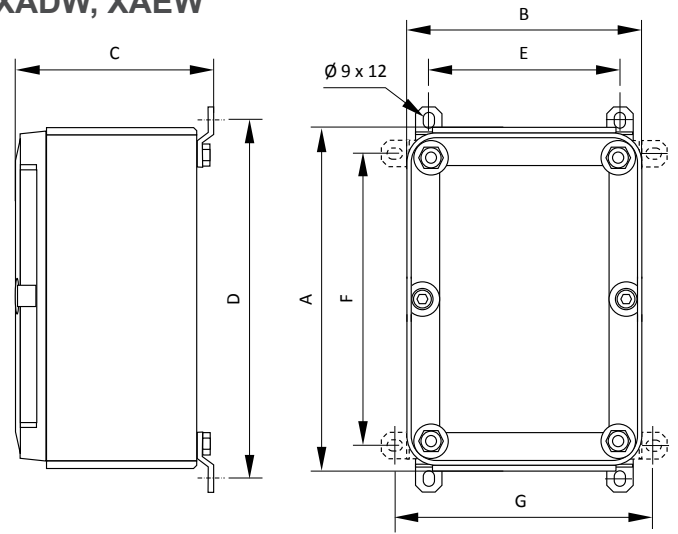

Dimensions

Product code	External			Fixing holes		Max. dissipated power at Tamb = 40°C (W)	Volume dm ³	Weight (kg)
	A	B	C	D x E	F x G			
DE8BA 180	185	185	160	196 x 144	144 x 196	50 W	2.66	13.5
DE8BA 258	258	180	158	276 x 146	231 x 191	50 W	4.30	16.0
DE8BA 278	278	218	153	306 x 174	234 x 246	50 W	4.80	22.0
DE8BA 321	320	220	180	336 x 148	264 x 220	120 W	6.55	26.0
DE8BA 322	320	220	170	336 x 148	264 x 220	120 W	5.80	24.0
DE8BA 450	452	222	186	466 x 148	394 x 220	120 W	10.40	30.0
XADW12	150	106	89	175 x 80	125 x 130	32 W	0.55	2.68
XADW13	190	106	89	215 x 80	165 x 130	32 W	0.82	3.10
XADW22	215	130	89	240 x 105	190 x 155	32 W	1.28	3.52
XAEW12	130	130	89	160 x 160	160 x 160	32 W	0.59	2.68

Number maximum of entries per side

Product code	M20 - 1/2"			M25 - 3/4"			M32 - 1"			M50 - 1" 1/2		
	A (1)	B (1)	Total (2)	A (1)	B (1)	Total (2)	A (1)	B (1)	Total (2)	A (1)	B (1)	Total (2)
DE8BA 180	5	5	20	5	5	20	4	4	16	1	1	4
DE8BA 258	8	4	24	8	4	24	6	3	18	2	1	6
DE8BA 278	8	5	26	8	5	26	5	4	18	3	1	8
DE8BA 321	-	2	4	-	2	4	-	2	4	-	-	-
DE8BA 322	-	5	10	-	5	10	-	3	6	-	1	2
DE8BA 450	-	5	10	-	5	10	-	3	6	-	1	1
XADW12	2	1	6	2	1	6	-	-	-	-	-	-
XADW13	3	1	8	3	1	8	-	-	-	-	-	-
XADW22	3	2	10	3	2	10	-	-	-	-	-	-
XAEW12	2	2	8	-	-	-	-	-	-	-	-	-

(1) A: on the long sides - B: on the short sides

(2) Number total of entries on the periphery



The junction boxes ERSA offers a wide range of dimensions. They can be used in highly restrictive hazardous areas.

The maximum number of terminals depends on the terminal section, the ambient temperature and the required temperature class.

On request they can be equipped with push buttons, selector switches, pilot lights, disconnectors, contactors and thermal overload relays.

TECHNICAL DATA

Material	Aluminium copper free
IP rating	IP65/66 according to EN/IEC 60529
Temperature range	-20°C ... +40°C or +50°C or +60°C
Certificate	INERIS 04ATEX0009X
Marking	II 2 GD or II 2 (1) GD or II 2 (2) GD Ex d IIB T6 ... T4 Gb - Ex tb IIIC T85°C ... T135°C or Ex d [ia] IIB T6 Gb - Ex tb IIIC T85°C Db or Ex d [ib] IIB T6 Gb - Ex tb IIIC T85°C Db
Surface treatment	Painting RAL 7032 - Other colour on request
Accessories upon on request	Breather valves Fixing bracket in stainless steel AISI 316L Earth stud Cable glands

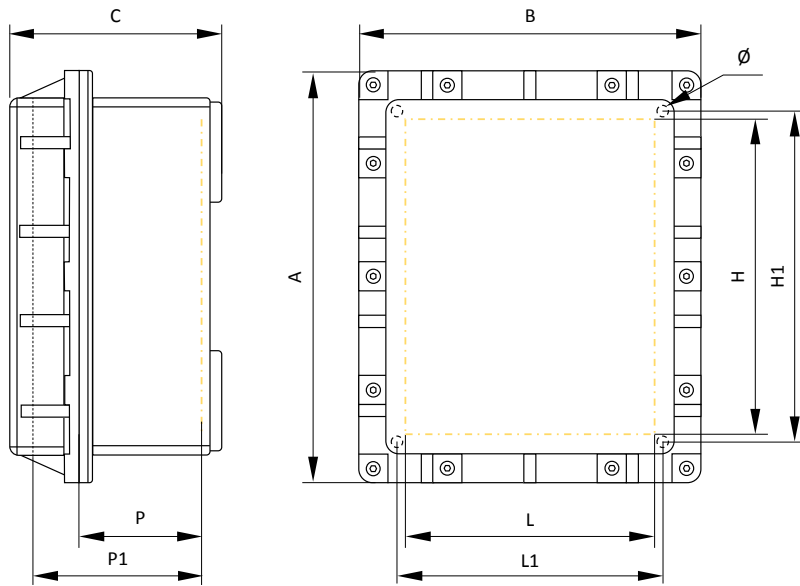

Dimensions

Product code	External			Internal				Fixing holes			Maximum dissipation (W)			Weight (kg)
	A	B	C	H	L	P	P1	H1 x L1	Ø	T6 (+40°C)	T5 (+50°C)	T4 (+60°C)		
ERSA1218	250	190	135	180	120	59	102	190 x 130	M8	54	62	121	6	
ERSA1232	390	190	126	320	120	68	97	320 x 120	M8	67	78	150	8	
ERSA1232A	390	190	177	320	120	68	148	320 x 120	M8	74	86	163	9	
ERSA1725A	320	240	190	250	170	68	136	225 x 155	M8	63	73	140	7	
ERSA2134	420	285	141	340	210	75	126	330 x 190	M10	130	150	279	20	
ERSA2835	425	355	172	350	280	116	164	335 x 265	M10	145	167	309	23	
ERSA2853	615	370	212	530	280	127	177	520 x 290	M12	252	291	519	36	
ERSA4363	730	530	305	640	440	190	210	575 x 375	M12	360	412	706	85	

Number maximum of entries per side

Product code	M16 - 1/2"			M20 - 3/4"			M25 - 1"			M32 - 1" 1/2			M50 - 2" 1/2			M63 - 2" 1/2		
	A (1)	B (1)	Total (2)	A (1)	B (1)	Total (2)	A (1)	B (1)	Total (2)	A (1)	B (1)	Total (2)	A (1)	B (1)	Total (2)	A (1)	B (1)	Total (2)
ERSA1218	4	3	7	2	3	5	2	2	4	4	2	6	-	-	-	-	-	-
ERSA1232	22	8	30	17	5	22	6	2	8	5	2	7	-	-	-	-	-	-
ERSA1232A	22	8	30	17	5	22	6	2	8	5	2	7	-	-	-	-	-	-
ERSA1725A	10	4	14	6	3	9	1	1	4	1	1	4	-	-	-	-	-	-
ERSA2134	18	20	38	12	9	21	4	7	11	3	5	8	-	-	-	-	-	-
ERSA2835	36	30	66	30	34	68	14	12	26	11	9	20	9	7	16	3	2	5
ERSA2853	85	29	114	41	21	62	25	14	39	12	8	20	5	3	8	1	1	2
ERSA4363	96	66	162	80	52	132	28	20	48	22	16	38	10	6	16	1	1	2

(1) A: on the long sides - B: on the short sides

(2) Number total of entries on the periphery



Enclosures and control cabinets

Content

Page

Flameproof enclosures - Explosion gas group IIB or IIB + H₂

Enclosures heavy series DE8BC in carbon steel	82
Enclosures heavy series DE8BC in stainless steel	84
Enclosures heavy series DE8BC in carbon steel with Ex e enclosure	86
Enclosures heavy series DE8BC in stainless steel with Ex e enclosure	86
Enclosures EJB series in aluminium	88
Enclosures EJB series in stainless steel	90
Enclosures EJB series in aluminium with Ex e enclosure	92
Enclosures EJB series in stainless steel with Ex e enclosure	94

Flameproof enclosures - Explosion gas group IIC

Enclosures DE8WH series in carbon steel	96
Enclosures DE8WH series in carbon steel with Ex e enclosure	98

Increased safety control cabinets

Control cabinets DE1GW in carbon steel or stainless steel	100
-----------------------------------------------------------	-----





The flameproof control cabinets DE8BC are designed for the control, automation, distribution boards, motor starters or any other application. They are suitable for designing of complex systems.

The wide range of sizes and dissipated powers, one of the wider of the market, allows optional selection to suit the customer's needs and applications.

Several enclosures can be assembled on a frame and provided with optional junction boxes and/or control and signalling units in increased safety (Ex e).

TECHNICAL DATA

Material	Painted steel
IP rating	IP65/66 according to EN/IEC 60529
Temperature range	-40°C or -20°C ... +40°C or +50°C or +60°C
Certificate	<p>As equipment INERIS 03ATEX0005X IECEX INE 13.0045X</p> <p>As component INERIS 09ATEX9021U IECEX INE 11.0025U</p>
Marking	<p>II 2 GD</p> <p>As equipment Ex d IIB T6 ... T4 Gb Ex d IIB + H₂ T6 ... T4 Gb Ex tb IIIC T85°C ... T135°C Db</p> <p>Ex d [ia] IIB T6 Gb Ex d [ia] IIB + H₂ T6 Gb Ex d [ib] IIB T6 Gb or Ex d [ib] IIB + H₂ T6 Gb Ex tb IIIC T85°C Db</p> <p>As component Ex d IIB Gb Ex d IIB + H₂ Gb Ex tb IIIC Db</p>
Surface treatment	Painting RAL 7032 - Other colour or offshore painting on request
Accessories on request	Increased safety (Ex e) control and terminal enclosure in stainless steel AISI 316L Breather valves Earth stud Lifting eyes Cable glands

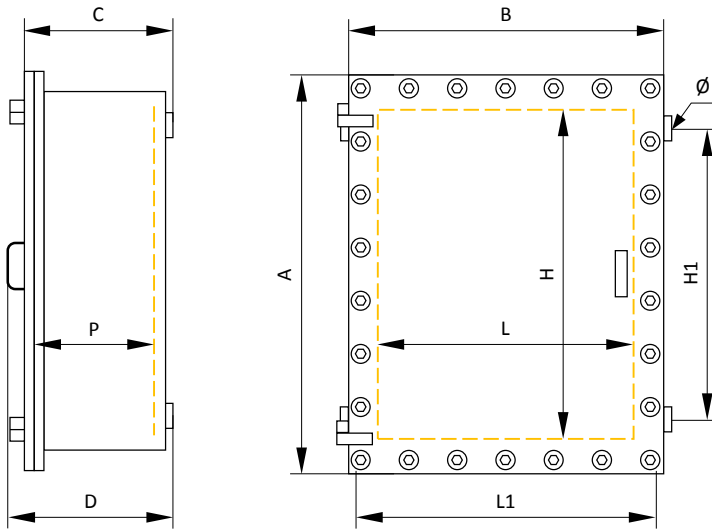

Dimensions

Product code	External + depth					Fixing holes		Mounting plate	Dissipation	Volume	Weight
	A	B	C	D	P	H1 x L1	Ø	H x L	max. (W)	dm ³	(kg)
DE8BC32	434	334	231	264	187	234 x 326	12	300 x 200	250	17.50	51
DE8BC351	474	354	233	266	187	274 x 346	12	350 x 225	250	21.06	61
DE8BC43	534	434	293	326	247	334 x 426	12	400 x 300	380	40.95	86
DE8BC44	544	544	306	339	247	334 x 526	20	400 x 400	380	52.65	113
DE8BC54	644	544	306	339	247	414 x 526	20	530 x 430	410	64.35	139
DE8BC64	744	544	308	341	247	514 x 526	20	630 x 430	470	76.05	154
DE8BC75	864	664	322	355	252	614 x 630	20	730 x 530	600	109.31	260
DE8BC86	964	764	369	402	292	714 x 734	20	830 x 630	600	168.51	370
DE8BC107	1164	864	379	412	292	908 x 868	20	1030 x 730	1200	240.18	530
DE8BC108	1164	864	424	457	337	908 x 868	20	1030 x 730	1400	275.62	580
DE8BC148	1590	940	510	543	412	1200 x 900	20	1430 x 780	2000	448.00	1100

Number maximum of entries per side

Product code	M20		M25		M32-M40-M42		M50		M63		M75	
	1/2"	Total (1)	1"	Total (1)	1" 1/2 - 1" 1/4	Total (1)	2"	Total (1)	2" 1/2	Total (1)	3"	Total (1)
DE8BC32	12	32	8	20	3	12	1	4	-	-	-	-
DE8BC351	12	24	8	18	3	8	1	4	-	-	-	-
DE8BC43	18	36	14	28	4	16	2	5	1	2	-	-
DE8BC44	20	40	16	30	5	20	3	6	1	3	-	-
DE8BC54	20	40	15	30	5	20	3	6	1	3	-	-
DE8BC64	28	60	18	50	7	28	4	9	1	4	-	-
DE8BC75	28	72	24	72	10	40	4	11	2	7	-	-
DE8BC86	32	112	28	100	20	80	5	17	2	8	1	4
DE8BC107	36	112	32	100	20	80	5	17	3	10	1	4
DE8BC108	36	112	32	100	20	80	5	17	3	10	1	4
DE8BC148	72	224	64	200	40	160	10	34	6	20	2	8

(1) Number total of entries on the periphery

Window for DE8BC (others on request)

Product code	Dimensions
REG 100 x 50	100 x 50
REG 100 x 100	100 x 100
REG 200 x 45	200 x 45
REG 235 x 75	235 x 75
REG D45	Ø 45
REG D60	Ø 60
REG D150	Ø 150





The flameproof control cabinets DE8BC in stainless steel AISI 316L are designed for the control, automation, distribution boards, motor starters or any other application. They are suitable for designing of complex systems for harsh environments and meet the requirements of use in ONSHORE or OFFSHORE.

The wide range of sizes and dissipated powers, one of the wider of the market, allows optional selection to suit the customer's needs and applications.

Several enclosures can be assembled on a frame and provided with optional junction boxes and/or control and signalling units in increased safety (Ex e).

TECHNICAL DATA

Material	Stainless steel AISI 316L
IP rating	IP65/66 according to EN/IEC 60529
Temperature range	-40°C or -20°C ... +40°C or +50°C or +60°C
Certificate	<p>As equipment INERIS 03ATEX0005X IECEX INE 13.0045X</p> <p>As component INERIS 09ATEX9021U IECEX INE 11.0025U</p>
Marking	<p>II 2 GD</p> <p>As equipment Ex d IIB T6 ... T4 Gb Ex d IIB + H₂ T6 ... T4 Gb Ex tb IIIC T85°C ... T135°C Db</p> <p>Ex d [ia] IIB T6 Gb Ex d [ia] IIB + H₂ T6 Gb Ex d [ib] IIB T6 Gb or Ex d [ib] IIB + H₂ T6 Gb Ex tb IIIC T85°C Db</p> <p>As component Ex d IIB Gb Ex d IIB + H₂ Gb Ex tb IIIC Db</p>
Surface treatment	Sand blasting - Offshore painting on request
Accessories on request	Increased safety (Ex e) control and terminal enclosure in stainless steel AISI 316L Breather valves Earth stud Lifting eyes Cable glands

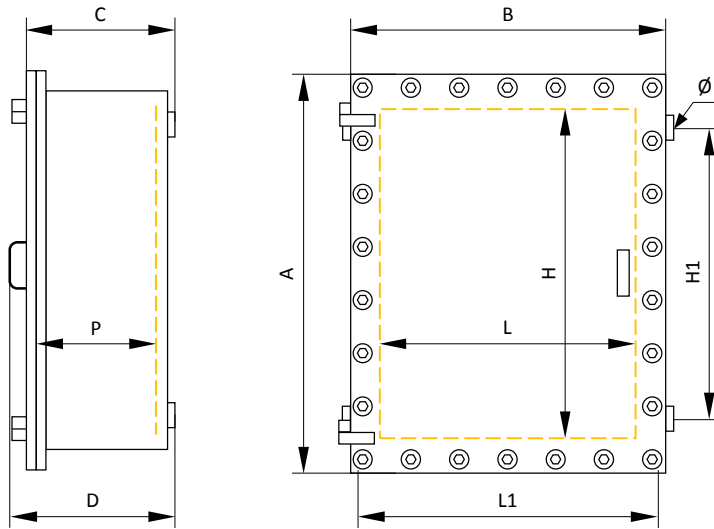

Dimensions

Product code	External + depth					Fixing holes		Mounting plate	Dissipation	Volume	Weight
	A	B	C	D	P	H1 x L1	Ø	H x L	max. (W)	dm ³	(kg)
DE8BC32S	434	334	231	264	187	234 x 326	12	300 x 200	250	17.50	51
DE8BC351S	474	354	233	266	187	274 x 346	12	350 x 225	250	21.06	61
DE8BC43S	534	434	293	326	247	334 x 426	12	400 x 300	380	40.95	86
DE8BC44S	544	544	306	339	247	334 x 526	20	400 x 400	380	52.65	113
DE8BC54S	644	544	306	339	247	414 x 526	20	530 x 430	410	64.35	139
DE8BC64S	744	544	308	341	247	514 x 526	20	630 x 430	470	76.05	154
DE8BC75S	864	664	322	355	252	614 x 630	20	730 x 530	600	109.31	260
DE8BC86S	964	764	369	402	292	714 x 734	20	830 x 630	600	168.51	370
DE8BC107S	1164	864	379	412	292	908 x 868	20	1030 x 730	1200	240.18	530
DE8BC108S	1164	864	424	457	337	908 x 868	20	1030 x 730	1400	275.62	580
DE8BC148S	1590	940	510	543	412	1200 x 900	20	1430 x 780	2000	448.00	1100

Number maximum of entries per side

Product code	M20		M25		M32-M40-M42		M50		M63		M75	
	1/2"	Total (1)	1"	Total (1)	1" 1/2 - 1" 1/4	Total (1)	2"	Total (1)	2" 1/2	Total (1)	3"	Total (1)
DE8BC32S	12	32	8	20	3	12	1	4	-	-	-	-
DE8BC351S	12	24	8	18	3	8	1	4	-	-	-	-
DE8BC43S	18	36	14	28	4	16	2	5	1	2	-	-
DE8BC44S	20	40	16	30	5	20	3	6	1	3	-	-
DE8BC54S	20	40	15	30	5	20	3	6	1	3	-	-
DE8BC64S	28	60	18	50	7	28	4	9	1	4	-	-
DE8BC75S	28	72	24	72	10	40	4	11	2	7	-	-
DE8BC86S	32	112	28	100	20	80	5	17	2	8	1	4
DE8BC107S	36	112	32	100	20	80	5	17	3	10	1	4
DE8BC108S	36	112	32	100	20	80	5	17	3	10	1	4
DE8BC148S	72	224	64	200	40	160	10	34	6	20	2	8

(1) Number total of entries on the periphery

Window for DE8BC (others on request)

Product code	Dimensions
REG 100 x 50	100 x 50
REG 100 x 100	100 x 100
REG 200 x 45	200 x 45
REG 235 x 75	235 x 75
REG D45	Ø 45
REG D60	Ø 60
REG D150	Ø 150





The flameproof control cabinets DE8BC with junction boxes and/or control enclosure are designed for the control, automation, distribution boards, motor starters or any other application.

They are suitable for designing of complex systems for harsh environments and meet the requirements of use in ONSHORE or OFFSHORE.

The wide range of sizes and dissipated powers, one of the wider of the market, allows to be closer to the customers needs and applications.

TECHNICAL DATA

Material	Enclosure in carbon steel painted or stainless steel AISI 316L increased safety (Ex e) enclosure in stainless steel AISI 316L
IP rating	IP65/66 according to EN/IEC 60529
Temperature range	-40°C or -20°C ... +40°C or +50°C or +60°C
Certificate	As equipment INERIS 03ATEX0005X IECEX INE 13.0045X As component INERIS 09ATEX9021U IECEX INE 11.0025U
Marking	II 2 GD As equipment Ex d IIB T6 ... T4 Gb Ex d IIB + H ₂ T6 ... T4 Gb Ex tb IIIC T85°C ... T135°C Db Ex d [ia] IIB T6 Gb Ex d [ia] IIB + H ₂ T6 Gb Ex d [ib] IIB T6 Gb or Ex d [ib] IIB + H ₂ T6 Gb Ex tb IIIC T85°C Db As component Ex d IIB Gb Ex d IIB + H ₂ Gb Ex tb IIIC Db
Surface treatment	Painting RAL 7032 - Other colour and/or offshore painting on request Sand blasting when stainless steel Increased safety (Ex e) enclosure in stainless steel AISI 316L
Accessories on request	Breather valves Earth stud Lifting eyes Cable glands

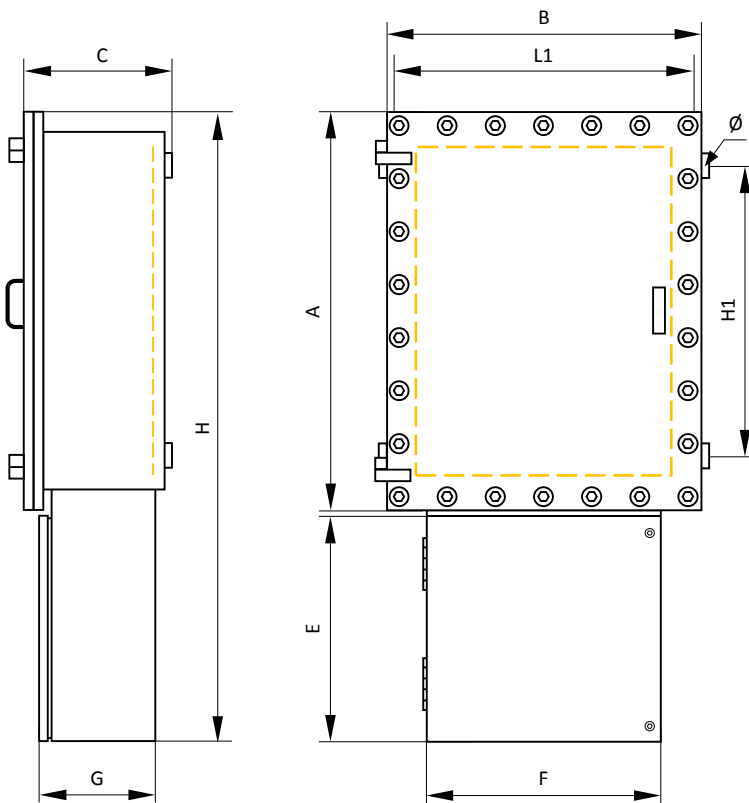

Dimensions

Product code Carbon steel	Product code Stainless steel	External							Fixing holes		Number of entries
		A	B	C	E	F	G	H	H1 x L1	Ø	M42
DE8BC32WH270	DE8BC32WH270S	434	334	231	250	270	176	702	234 x 326	12	3
DE8BC351WH270	DE8BC351WH270S	474	354	233	250	270	176	742	274 x 346	12	3
DE8BC43WH330	DE8BC43WH330S	534	434	293	250	330	230	802	334 x 426	12	3
DE8BC44WH330	DE8BC44WH330S	544	544	306	250	330	230	802	334 x 526	20	4
DE8BC44WH520	DE8BC44WH520S	544	544	306	330	520	230	887	334 x 526	20	4
DE8BC54WH330	DE8BC54WH330S	644	544	306	250	330	230	907	414 x 526	20	5
DE8BC54WH520	DE8BC54WH520S	644	544	306	330	520	230	987	414 x 526	20	5
DE8BC64WH330	DE8BC64WH330S	744	544	308	250	330	230	1007	514 x 526	20	5
DE8BC64WH520	DE8BC64WH520S	744	544	308	330	520	230	1087	514 x 526	20	5
DE8BC75WH520	DE8BC75WH520S	864	664	322	330	520	230	1197	614 x 630	20	7
DE8BC86WH670	DE8BC86WH670S	964	764	369	520	670	230	1539	714 x 734	20	10
DE8BC107WH670	DE8BC107WH670S	1164	864	379	520	670	230	1689	908 x 868	20	20
DE8BC108WH670	DE8BC108WH670S	1164	864	424	520	670	230	1689	908 x 868	20	20
DE8BC148WH670	DE8BC148WH670S	1590	940	510	520	670	230	2112	1200 x 900	20	20

Window for DE8BC (others on request)

Product code	Dimensions
REG 100 x 50	100 x 50
REG 100 x 100	100 x 100
REG 200 x 45	200 x 45
REG 235 x 75	235 x 75
REG D45	Ø 45
REG D60	Ø 60
REG D150	Ø 150





The EJB range of Ex d IIB or IIB + H₂ enclosures are in manufactured copper free aluminium and designed for control, monitoring, automation, distribution boards, motor starters or any other application.

They are suitable for ONSHORE environments.

Optionally they can be provided with junction boxes and/or control and signalling units in increased safety (Ex e).

TECHNICAL DATA

Material	Copper free aluminium, type 43100
IP rating	IP66 according to EN/IEC 60529
Temperature range	-20°C ... +40°C or +50°C or +60°C -50°C ... +40°C or +50°C or +60°C
Certificate	As equipment INERIS 14ATEX0001X IECEX INE 14.0006X As component INERIS 14ATEX9001U IECEX INE 14.0005U
Marking	II 2 GD As equipment Ex d IIB T6 ... T4 Gb Ex tb IIIC T85°C ... T135°C Db As component Ex d IIB Gb Ex tb IIIC Db
Surface treatment	Painting RAL 7032 - Other colour and/or offshore painting on request
Accessories on request	Increased safety (Ex e) control and terminal enclosure in stainless steel AISI 316L Breather valves Fixing brackets in stainless steel AISI 316L Earth stud Cable glands

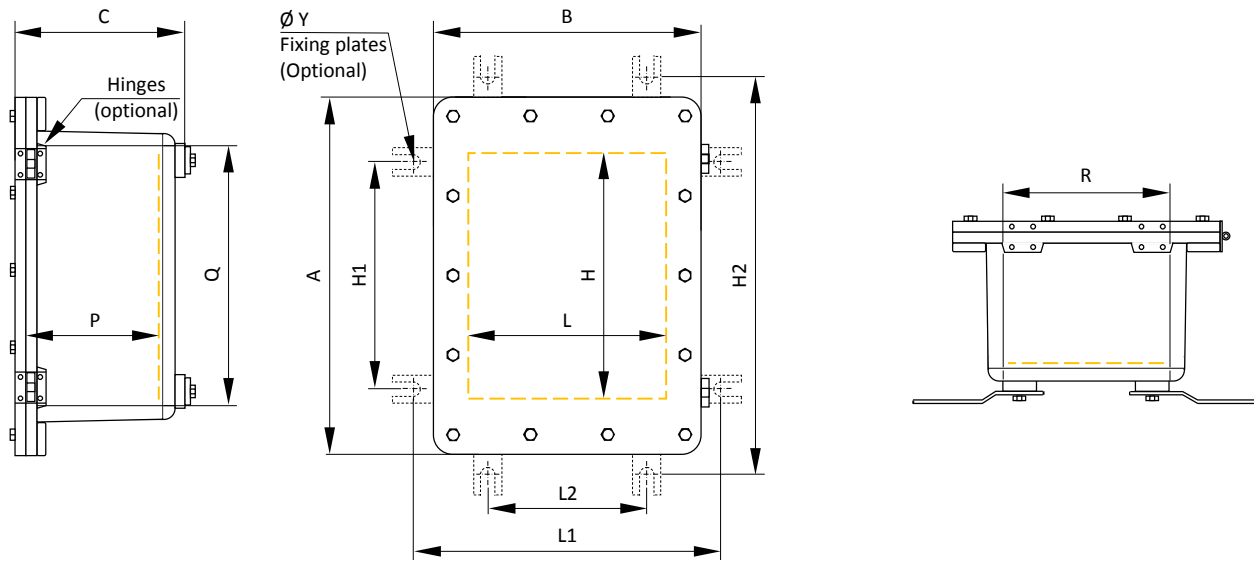

Dimensions

Product code	External			Internal			Fixing holes		Mounting plate	Fixing bolts	Weight (kg)
	A	B	C	P	Q	R	H1 x L1	H2 x L2	H x L	to apply	
EJB A	314	250	173	127	228	164	180 x 241	301 x 120	211 x 148	M8 x 12	10
EJB B	423	247	229	187	341	167	290 x 249	411 x 128	321 x 146	M8 x 12	16
EJB C	488	413	259	202	382	307	336 x 413.5	495.5 x 254	360 x 291	M8 x 12	35
EJB D	530	490	259	202	421	381	360 x 479.5	519.5 x 320	394 x 358	M8 x 12	42
EJB E	594	539	314	233	474	419	400 x 559	599 x 360	446 x 391	M10 x 20	78
EJB F	829	450	311	233	713	329	630 x 449	833 x 250	670 x 294	M10 x 20	90
EJB G	833	613	314	233	714	493	630 x 604	829 x 405	670 x 450	M10 x 20	124
EJB H	833	613	412	334	714	494	630 x 604	829 x 405	670 x 450	M10 x 20	135

Number maximum of entries per side

Size of entries	EJB A		EJB B		EJB C		EJB D		EJB E		EJB F		EJB G		EJB H	
	S1 (1)	S2 (1)	S1 (1)	S2 (1)	S1 (1)	S2 (1)	S1 (1)	S2 (1)	S1 (1)	S2 (1)	S1 (1)	S2 (1)	S1 (1)	S2 (1)	S1 (1)	S2 (1)
M20 or 1/2"	8	6	12	6	20	16	24	22	30	24	55	26	55	32	60	38
M25 or 3/4"	8	4	6	2	12	9	22	16	25	20	38	18	40	22	44	24
M32 or 1"	3	2	3	2	10	8	11	9	13	11	30	15	34	18	36	20
M50 or 1 1/2"	2	1	2	1	4	3	8	8	8	8	14	6	16	12	17	13
M63 or 2"	1	1	1	1	3	2	3	3	4	4	10	4	11	5	12	6
M75 or 2" 1/2	-	-	-	-	2	2	2	2	3	2	4	2	6	4	6	4
M80 or 3"	-	-	-	-	1	1	1	1	2	2	3	1	5	3	5	3

(1) S1: on the long sides - S2: on the short sides

Accessories and windows

Product code	Description
W80110 *	Windows size 80 x 100 mm
W80240 *	Windows size 80 x 240 mm
W120120 *	Windows size 120 x 120 mm
W160160 *	Windows size 160 x 160 mm
W200200 *	Windows size 200 x 200 mm
W140310 *	Windows size 140 x 310 mm
W190340 *	Windows size 190 x 340 mm
W215420 *	Windows size 215 x 420 mm
Hinges AB	Couple of hinges for EJB size A and B
Hinges DE	Couple of hinges for EJB size D and E
Hinges FH	Couple of hinges for EJB size F, G and H
MOUTBRA AB	Couple of mounting bracket for EJB size A and B
MOUTBRA DE	Couple of mounting bracket for EJB size D and E
MOUTBRA FH	Couple of mounting bracket for EJB size F, G and H
DRAVAL	Drain valve

* As standard: horizontal layout





The EJB range of Ex d IIB or IIB + H₂ enclosures are in manufactured stainless steel AISI 316L and designed for control, monitoring, automation, distribution boards, motor starters or any other application.

They are suitable for ONSHORE and OFFSHORE environments.

Optionally, they can be provided with junction boxes and/or control and signalling units in increased safety (Ex e).

TECHNICAL DATA

Material	Stainless steel AISI 316L
IP rating	IP66 according to EN/IEC 60529
Temperature range	-20°C ... +40°C or +50°C or +60°C -50°C ... +40°C or +50°C or +60°C
Certificate	As equipment INERIS 14ATEX0001X IECEX INE 14.0006X As component INERIS 14ATEX9001U IECEX INE 14.0005U
Marking	II 2 GD As equipment Ex d IIB T6 ... T4 Gb Ex tb IIIC T85°C ... T135°C Db As component Ex d IIB Gb Ex tb IIIC Db
Surface treatment	Sand blasting
Accessories on request	Increased safety (Ex e) control and terminal enclosure in stainless steel AISI 316L Breather valves Fixing brackets in stainless steel AISI 316L Earth stud Cable glands

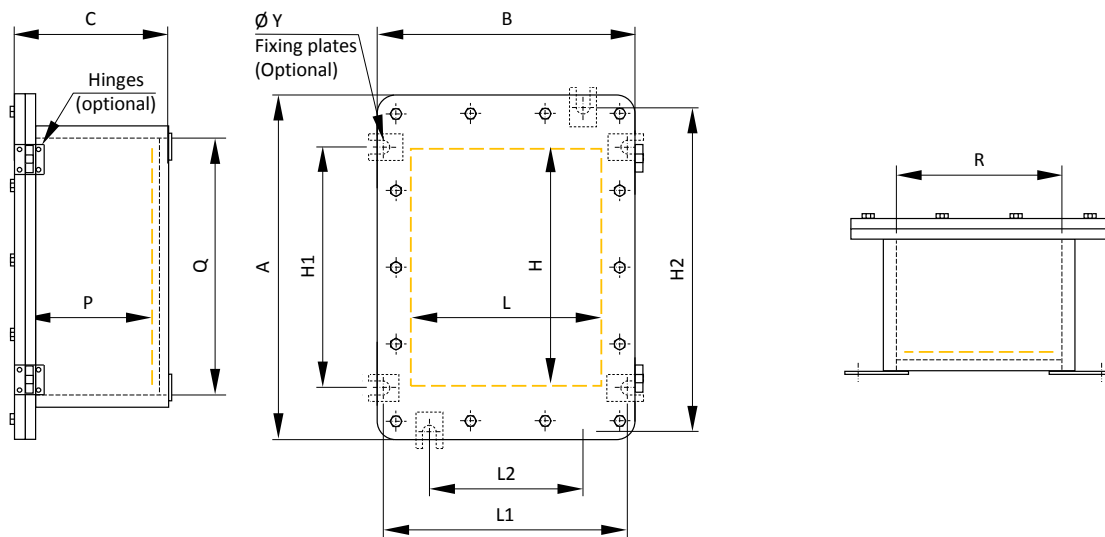

Dimensions

Product code	External			Internal			Fixing holes		Mounting plate	Fixing bolts	Weight (kg)
	A	B	C	P	Q	R	H1 x L1	H2 x L2	H x L	to apply	
EJB AS	319	254	171	141	235	170	-	295 x 110	185 x 120	M10 x 20	32
EJB BS	429	254	231	196	345	170	285 x 230 **	-	295 x 120	M10 x 20	42
EJB CS	491	416	252	217	390	315	330 x 376	-	340 x 265	M10 x 20	80
EJB DS	536	496	251	216	430	390	370 x 451	-	380 x 340	M10 x 20	99
EJB ES	601	546	266	221	495	440	405 x 509	-	435 x 380	M10 x 20	143
EJB FS	846	461	311	266	735	350	605 x 419	-	675 x 290	M10 x 20	180
EJB GS	836	616	308	253	725	505	605 x 590	-	675 x 455	M10 x 20	281
EJB HS	836	616	403	348	725	505	605 x 590	-	675 x 455	M10 x 20	310

** Optional only 2 mounting plates are supplied: on the top right and bottom left

Number maximum of entries per side

Size of entries	EJB A		EJB B		EJB C		EJB D		EJB E		EJB F		EJB G		EJB H	
	S1 (1)	S2 (1)	S1 (1)	S2 (1)	S1 (1)	S2 (1)	S1 (1)	S2 (1)	S1 (1)	S2 (1)	S1 (1)	S2 (1)	S1 (1)	S2 (1)	S1 (1)	S2 (1)
M20 or 1/2"	8	6	12	6	20	16	24	22	30	24	55	26	55	32	60	38
M25 or 3/4"	8	4	6	2	12	9	22	16	25	20	38	18	40	22	44	24
M32 or 1"	3	2	3	2	10	8	11	9	13	11	30	15	34	18	36	20
M50 or 1 1/2"	2	1	2	1	4	3	8	8	8	8	14	6	16	12	17	13
M63 or 2"	1	1	1	1	3	2	3	3	4	4	10	4	11	5	12	6
M75 or 2" 1/2	-	-	-	-	2	2	2	2	3	2	4	2	6	4	6	4
M80 or 3"	-	-	-	-	1	1	1	1	2	2	3	1	5	3	5	3

(1) S1: on the long sides - S2: on the short sides

Accessories and windows

Product code	Description
W80110 *	Windows size 80 x 100 mm
W80240 *	Windows size 80 x 240 mm
W120120 *	Windows size 120 x 120 mm
W160160 *	Windows 160 x 160 mm
W200200 *	Windows 200 x 200 mm
W140310 *	Windows 140 x 310 mm
W190340 *	Windows 190 x 340 mm
W215420 *	Windows 215 x 420 mm
Hinges AB	Couple of hinges for EJB size A and B
Hinges DE	Couple of hinges for EJB size D and E
Hinges FH	Couple of hinges for EJB size F, G and H
MOUTBRA AB	Couple of mounting bracket for EJB size A and B
MOUTBRA DE	Couple of mounting bracket for EJB size D and E
MOUTBRA FH	Couple of mounting bracket for EJB size F, G and H
DRAVAL	Drain valve

* As standard: horizontal layout

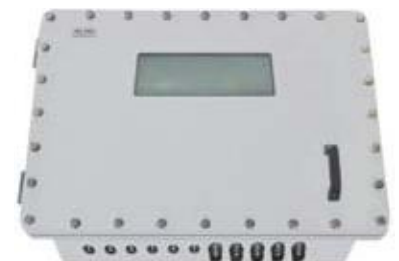



The EJB range of Ex d IIB or IIB + H₂ enclosures are in manufactured copper free aluminium and designed for control, monitoring, automation, distribution boards, motor starters or any other application.

They are suitable for ONSHORE environments.

TECHNICAL DATA

Material	Copper free aluminium, type 43100 Increased safety (Ex e) enclosure in stainless steel AISI 316L
IP rating	IP66 according to EN/IEC 60529
Temperature range	-20°C ... +40°C or +50°C or +60°C -50°C ... +40°C or +50°C or +60°C
Certificate	As equipment INERIS 14ATEX0001X IECEX INE 14.0006X As component INERIS 14ATEX9001U IECEX INE 14.0005U
Marking	II 2 GD As equipment Ex d IIB T6 ... T4 Gb Ex tb IIIC T85°C ... T135°C Db As component Ex d IIB Gb Ex tb IIIC Db
Surface treatment	Painting RAL 7032 - Other colour and/or offshore painting on request
Accessories on request	Breather valves Fixing brackets in stainless steel AISI 316L Earth stud Cable glands

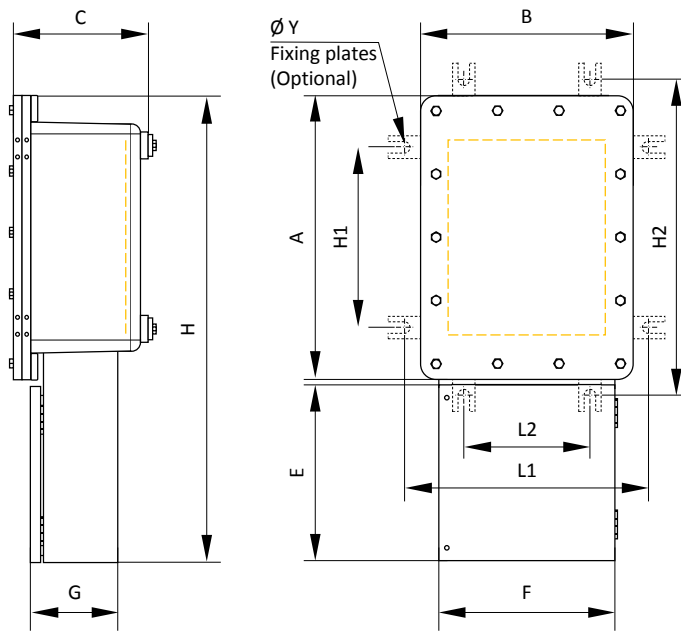

Product code	External							Fixing holes		Mounting plate	Fixing Y	Weight (kg)
	A	B	C	E	F	G	H	H1 x L1	H2 x L2			
EJB A DE1GW1	314	250	173		On request			180 x 241	301 x 120	211 x 148	10	10
EJB B DE1GW1	423	247	229		On request			290 x 249	411 x 128	321 x 146	10	16
EJB C DE1GW1	488	413	259	200	300	200	698	336 x 413.5	495.5 x 254	360 x 291	10	42
EJB D DE1GW1	530	490	259	300	400	200	840	360 x 479.5	519.5 x 320	394 x 358	10	51
EJB E DE1GW1	594	539	314	300	400	200	904	400 x 559	599 x 360	446 x 391	11	87
EJB F DE1GW1	829	450	311	300	400	200	1140	630 x 449	833 x 250	670 x 294	11	99
EJB G DE1GW1	833	613	314	400	500	250	1243	630 x 604	829 x 405	670 x 450	11	138
EJB H DE1GW1	833	613	412	400	500	250	1213	630 x 604	829 x 405	670 x 450	11	149

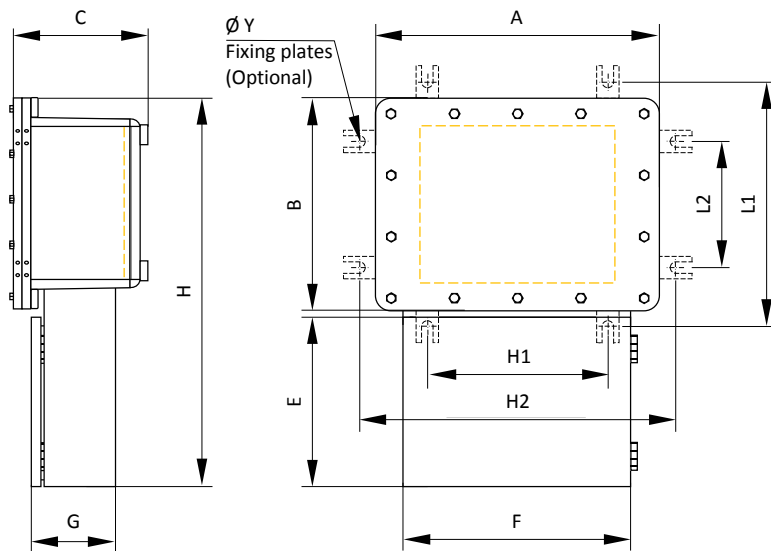

Product code	External							Fixing holes		Mounting plate	Fixing Y	Weight (kg)
	A	B	C	E	F	G	H	H1 x L1	H2 x L2			
EJB A DE1GW2	314	250	173	250	300	150	510	180 x 241	301 x 120	211 x 148	10	18
EJB B DE1GW2	423	247	229	250	300	150	507	290 x 249	411 x 128	321 x 146	10	24
EJB C DE1GW2	488	413	259	300	400	200	723	336 x 413.5	495.5 x 254	360 x 291	10	42
EJB D DE1GW2	530	490	259	300	400	200	800	360 x 479.5	519.5 x 320	394 x 358	10	51
EJB E DE1GW2	594	539	311	300	500	200	849	400 x 559	599 x 360	446 x 391	11	87
EJB F DE1GW2	830	450	311	400	600	250	750	630 x 449	833 x 250	670 x 294	11	102
EJB G DE1GW2	833	613	319	400	600	250	1023	630 x 604	829 x 405	670 x 450	11	140
EJB H DE1GW2	833	613	412	500	700	250	1123	630 x 604	829 x 405	670 x 450	11	151



The EJB range of Ex d IIB or IIB + H₂ enclosures are in manufactured stainless steel AISI 316L and designed for control, monitoring, automation, distribution boards, motor starters or any other application.

They are suitable for ONSHORE and OFFSHORE environments.

TECHNICAL DATA

Material	Stainless steel AISI 316L
IP rating	IP66 according to EN/IEC 60529
Temperature range	-20°C ... +40°C or +50°C or +60°C -50°C ... +40°C or +50°C or +60°C
Certificate	As equipment INERIS 14ATEX0001X IECEX INE 14.0006X As component INERIS 14ATEX9001U IECEX INE 14.0005U
Marking	II 2 GD As equipment Ex d IIB T6 ... T4 Gb Ex tb IIIC T85°C ... T135°C Db As component Ex d IIB Gb Ex tb IIIC Db
Surface treatment	Sand blasting
Accessories on request	Breather valves Fixing brackets in stainless steel AISI 316L Earth stud Cable glands

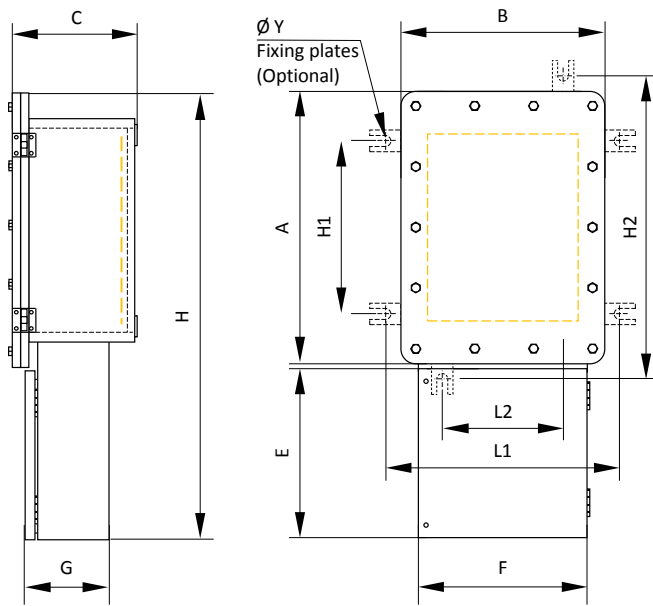

Product code	External							Fixing holes		Mounting plate	Fixing Y	Weight (kg)
	A	B	C	E	F	G	H	H1 x L1	H2 x L2			
EJB AS GW1	319	254	171		On request			-	295 x 110	185 x 120	10	32
EJB BS GW1	429	254	231		On request			285 x 230 **	-	295 x 120	10	42
EJB CS GW1	491	416	252	200	300	200	751	330 x 376	-	340 x 265	10	87
EJB DS GW1	536	496	251	300	400	200	846	370 x 451	-	380 x 340	10	109
EJB ES GW1	601	546	266	300	400	200	856	405 x 509	-	435 x 380	11	152
EJB FS GW1	846	461	311	300	400	200	1156	605 x 419	-	675 x 290	11	190
EJB GS GW1	836	616	308	400	500	250	1246	605 x 590	-	675 x 455	11	295
EJB HS GW1	836	616	403	400	500	250	1246	605 x 590	-	675 x 455	11	325

** Optional only 2 mounting plates are supplied: on the top right and bottom left

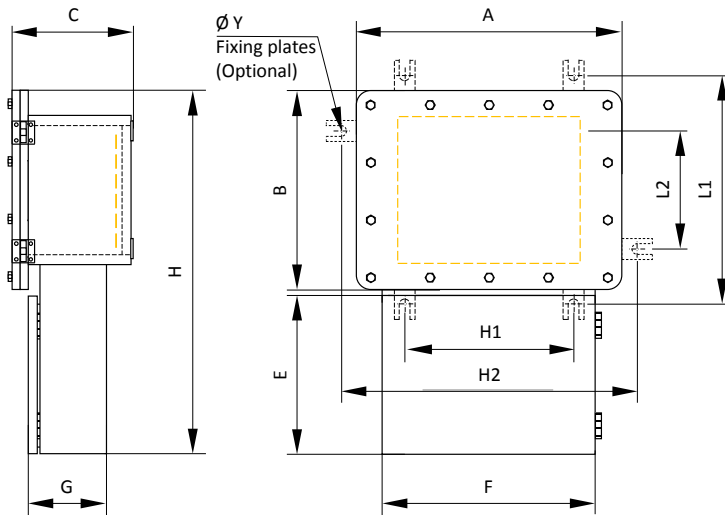

Product code	External							Fixing holes		Mounting plate	Fixing bolts Y	Weight (kg)
	A	B	C	E	F	G	H	H1 x L1	H2 x L2			
EJB AS GW2	319	254	171	250	300	150	514	-	295 x 110	185 x 120	10	39
EJB BS GW2	429	254	231	250	300	150	514	285 x 230 **	-	295 x 120	10	49
EJB CS GW2	491	416	252	300	400	200	726	330 x 376	-	340 x 265	10	90
EJB DS GW2	536	496	251	300	400	200	806	370 x 451	-	380 x 340	10	109
EJB ES GW2	601	546	266	300	500	200	856	405 x 509	-	435 x 380	11	157
EJB FS GW2	846	461	311	400	600	250	871	605 x 419	-	675 x 290	11	196
EJB GS GW2	836	616	308	400	600	250	1026	605 x 590	-	675 x 455	11	296
EJB HS GW2	836	616	403	500	700	250	1026	605 x 590	-	675 x 455	11	327

** Optional only 2 mounting plates are supplied: on the top of the left side and on the bottom of the right side



The DE8WH flameproof enclosures are designed for control, monitoring, automation, motor starters, or other complex application in hazardous areas requiring the highest level of protection.

They suit to very aggressive environments and meet the use requirements for ONSHORE and OFFSHORE.

Optionally, they may be provided entirely in stainless steel AISI 316L with a hinged lid on, a junction box increased safety (Ex e) for control and signalling increased safety.

TECHNICAL DATA

Material	Carbon steel, cover in aluminium copper free
IP rating	IP65/66 according to EN/IEC 60529
Temperature range	-40°C ... +40°C or +50°C or +60°C
Certificate	<p>As equipment INERIS 03ATEX121X IECEX INE 14.0010X</p> <p>As component INERIS 14ATEX9004U IECEX INE 14.0009U</p>
Marking	<p>II 2 GD or II 2 (1) GD or II 2 (2) GD</p> <p>As equipment Ex d IIC T6 ... T4 Gb Ex tb IIIC T85°C ... T135°C Db or Ex d [ia Ga] IIC T6 Gb - Ex tb [ia Da] IIIC T85°C Db or Ex d [ib] IIC T6 Gb - Ex tb [ib] IIIC T85°C Db</p> <p>As component Ex d IIC Gb Ex tb IIIC Db</p>
Surface treatment	Painting RAL 7032 - Other colour and/or offshore painting on request
Accessories on request	Distribution panel Ex e Breather valves Earth stud Cable glands

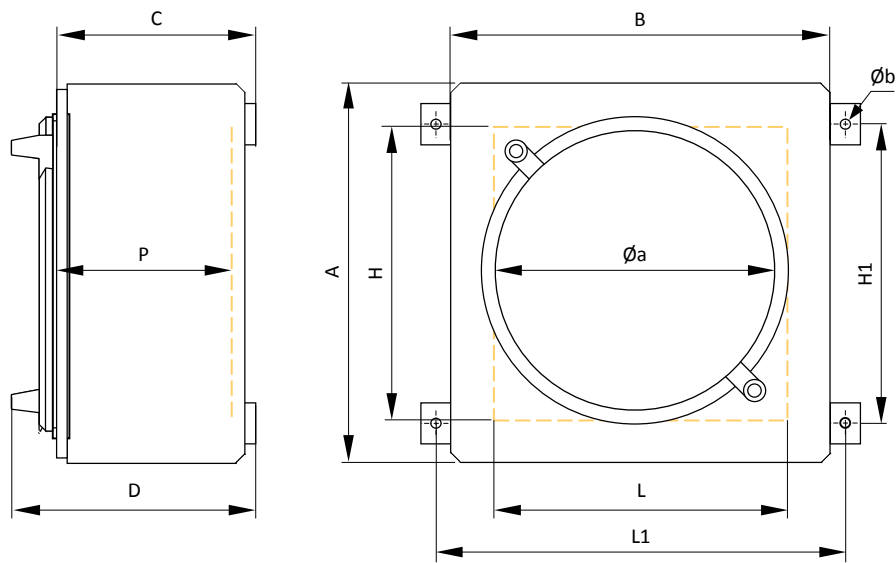

Dimensions

Product code	External + depth						Fixing holes		Mounting plate	Dissipation	Volume	Weight
	A	B	C	D	Øa	P	H1 x L1	Øb	H x L	max. (W)	dm ³	(kg)
DE8WH26	260	260	230	230	230	186	116 x 305	9	Ø 190	60	6	12
DE8WH261	260	260	185	199	230	103	116 x 305	9	Ø 190	30	3	9
DE8WH32	330	330	425	433	250	257	210 x 380	14	248 x 248	165	29	65
DE8WH43	520	520	425	433	400	257	400 x 570	14	398 x 398	270	73	125
DE8WH64	670	670	425	433	550	257	550 x 720	14	548 x 548	330	122	200
DE8WH107	1040	670	425	492	550	312	550 x 720	14	916 x 548	600	190	260

Number maximum of entries per side

Product code	M20 - 1/2"		M25 - 1"		M32-M40-M42-1" 1/2 - 1" 1/4		M50 - 2"		M63 - 2" 1/2		M75 - 3"	
	Per side	Total (1)	Per side	Total (1)	Per side	Total (1)	Per side	Total (1)	Per side	Total (1)	Per side	Total (1)
DE8WH26	3	12	2	8	1	4	-	-	-	-	-	-
DE8WH261	3	12	2	8	1	4	-	-	-	-	-	-
DE8WH32	14	56	8	32	4	16	2	8	-	-	-	-
DE8WH43	32	128	20	80	15	60	5	20	2	8	1	4
DE8WH64	39	156	26	104	19	76	6	24	2	8	1	4
DE8WH107	39	156	26	104	19	76	6	24	2	8	1	4

(1) Number total of entries on the periphery



The DE8WH flameproof enclosures with an increased safety (Ex e) enclosure are designed for control, monitoring, automation, motor starters, or other complex application in hazardous areas requiring the highest level of protection.

They suit to very aggressive environments and meet the use requirements for ONSHORE and OFFSHORE.

Optionally, they may be provided entirely in stainless steel AISI 316L with a hinged lid on.

TECHNICAL DATA

Material	Carbon steel, cover in aluminium copper free, Ex e enclosure in stainless steel AISI 316L
IP rating	IP65/66 according to EN/IEC 60529
Temperature range	-40°C ... +40°C or +50°C or +60°C
Certificate	<p>As equipment INERIS 03ATEX121X IECEX INE 14.0010X</p> <p>As component INERIS 14ATEX9004U IECEX INE 14.0009U</p>
Marking	<p>II 2 GD or II 2 (1) GD or II 2 (2) GD</p> <p>As equipment Ex d IIC T6 ... T4 Gb Ex tb IIIC T85°C ... T135°C Db or Ex d [ia Ga] IIC T6 Gb - Ex tb [ia Da] IIIC T85°C Db or Ex d [ib] IIC T6 Gb - Ex tb [ib] IIIC T85°C Db</p> <p>As component Ex d IIC Gb Ex tb IIIC Db</p>
Surface treatment	Painting RAL 7032 - Other colour and/or offshore painting on request
Accessories on request	Breather valves Earth stud Cable glands

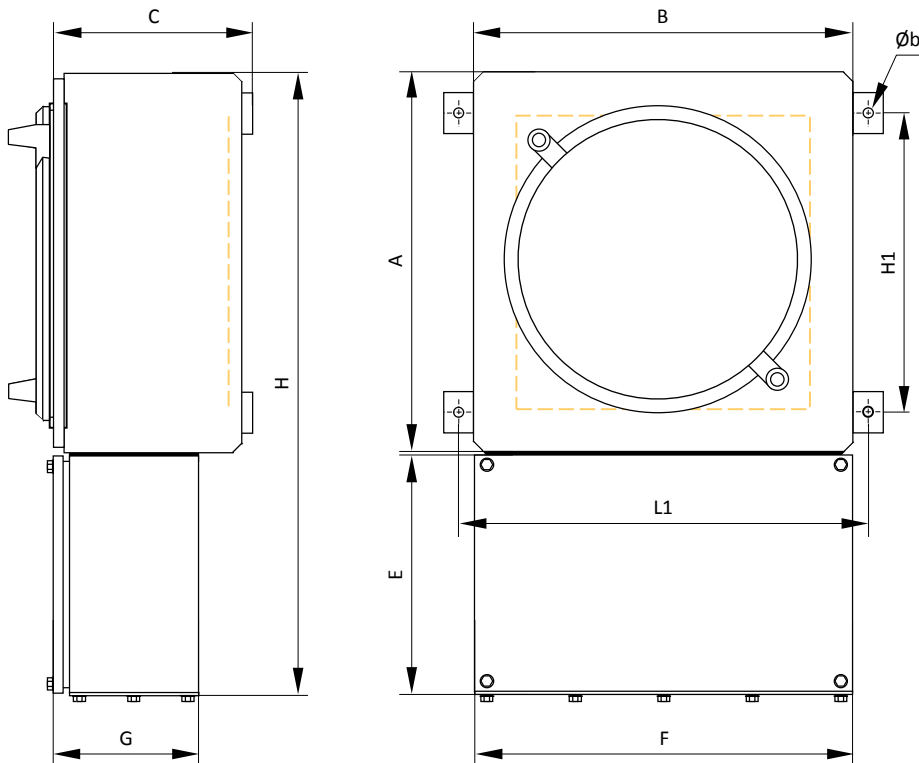

Dimensions with Ex e enclosures not equipped with hinges

Product code	External							Fixing holes		Mounting plate	Number of entries
	A	B	C	E	F	G	H	H1 x L1	Øb	H x L	M42 x 1,5
DE8WH26WF16	260	260	230	160	260	90	422	116 x 305	9	Ø 190	1
DE8WH261WF16	260	260	185	160	260	90	422	116 x 305	9	Ø 190	1
DE8WH32WH27	330	330	425	250	270	170	593	210 x 380	14	248 x 248	4
DE8WH32WH33	330	330	425	250	330	230	593	210 x 380	14	248 x 248	4
DE8WH43WH33	520	520	425	250	330	230	783	400 x 570	14	398 x 398	6
DE8WH43WH52	520	520	425	330	520	230	863	400 x 570	14	398 x 398	8
DE8WH64WH52	670	670	425	330	520	230	1013	550 x 720	14	548 x 548	8
DE8WH64WH67	670	670	425	520	670	230	1203	550 x 720	14	548 x 548	12
DE8WH107WH67	1040	670	425	520	670	230	1573	550 x 720	14	916 x 548	12

Dimensions with Ex e enclosures equipped with hinges

Product code	External							Fixing holes		Mounting plate	Number of entries
	A	B	C	E	F	G	H	H1 x L1	Øb	H x L	M42 x 1,5
DE8WH26WF16	260	260	230	160	260	90	432	116 x 305	9	Ø 190	1
DE8WH261WF16	260	260	185	160	260	90	432	116 x 305	9	Ø 190	1
DE8WH32WH27	330	330	425	250	270	170	689	210 x 380	14	248 x 248	4
DE8WH32WH33	330	330	425	250	330	230	689	210 x 380	14	248 x 248	4
DE8WH43WH33	520	520	425	250	330	230	879	400 x 570	14	398 x 398	6
DE8WH43WH52	520	520	425	330	520	230	959	400 x 570	14	398 x 398	8
DE8WH64WH52	670	670	425	330	520	230	1109	550 x 720	14	548 x 548	8
DE8WH64WH67	670	670	425	520	670	230	1299	550 x 720	14	548 x 548	12
DE8WH107WH67	1040	670	425	520	670	230	1629	550 x 720	14	916 x 548	12



The DE1GW cabinets are designed for making solutions or systems in harsh environments.

They meet the use requirements for ONSHORE and OFFSHORE and the highest level of protection in hazardous area.

They can also be equipped with push buttons, selector switches, pilot lights, measurement instruments.

They are equipped with a mounting plate and the fixing brackets.

TECHNICAL DATA

Material	Carbon steel painted or stainless steel AISI 316L
IP rating	IP65/66 according to EN/IEC 60529
Temperature range	-40°C ... +60°C (T4) -40°C ... +50°C (T5) -40°C ... +40°C (T6)
Certificate	INERIS 03ATEX0006
Marking	II 2 GD Ex e IIC T6 ... T4 Gb Ex tb IIIC T85°C ... T135°C Db
Surface treatment	Carbon steel: painting RAL 7035, other colour on request Stainless steel: bead blasting
Accessories on request	External hinges Breather valves Earth stud Cover locking facilities Gland plates Cable glands Electropolished treatment

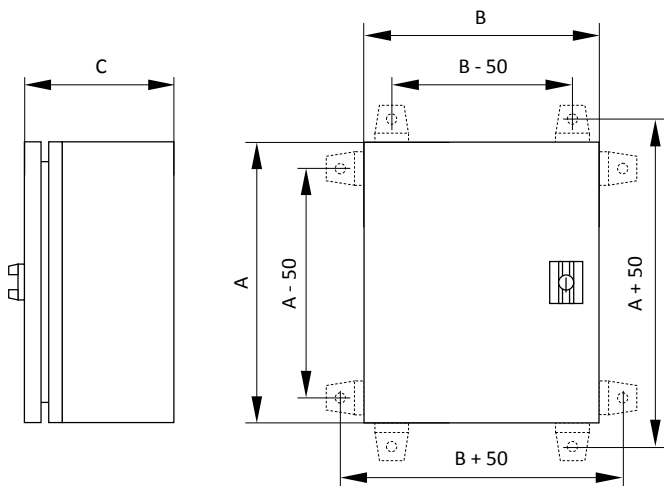

Dimensions

Product codes carbon steel	Product codes stainless steel	External			Fixing See drawing	Max. dissipated power at Tamb = 40°C (W)	Volume (dm ³)	Weight (kg)
		A	B	C				
DE1GW302020	DE1GWS302020	200	300	200	"	30 W	12	5
DE1GW302515	DE1GWS302515	250	300	150	"	30 W	11	5.15
DE1GW282820	DE1GWS282820	280	280	200	"	40 W	15	7
DE1GW403020	DE1GWS403020	300	400	200	"	50 W	24	8.6
DE1GW383820	DE1GWS383820	380	380	200	"	50 W	29	9.3
DE1GW385720	DE1GWS385720	570	380	200	"	65 W	43	11.2
DE1GW504025	DE1GWS504025	400	500	250	"	90 W	50	14.1
DE1GW575720	DE1GWS575720	570	570	200	"	105 W	65	17.9
DE1GW577627	DE1GWS577627	760	570	270	"	140 W	117	23.9
DE1GW706030	DE1GWS706030	600	700	300	"	180 W	126	26.1
DE1GW907030	DE1GWS907030	700	900	300	"	240 W	189	49.8
DE1GW769527	DE1GWS769527	950	760	270	"	240 W	195	36.7

Other sizes available on request

Number maximum of entries per side

Product code	M16	M18	M20	M25	M32	M40	M50	M63
DE1GW302020	10	10	10	8	5	3	2	-
DE1GW302515	10	10	10	8	5	3	2	-
DE1GW282820	10	10	10	8	5	3	2	-
DE1GW403020	28	24	24	18	15	8	6	2
DE1GW383820	28	24	24	18	15	8	6	2
DE1GW385720	66	50	50	45	28	18	15	6
DE1GW504025	66	50	50	45	28	18	15	6
DE1GW575720	66	50	50	45	28	18	15	6
DE1GW577627	152	112	112	75	60	40	24	15
DE1GW706030	152	112	112	75	60	40	24	15
DE1GW907030	184	133	133	90	75	48	30	21
DE1GW769527	184	133	133	90	75	48	30	21

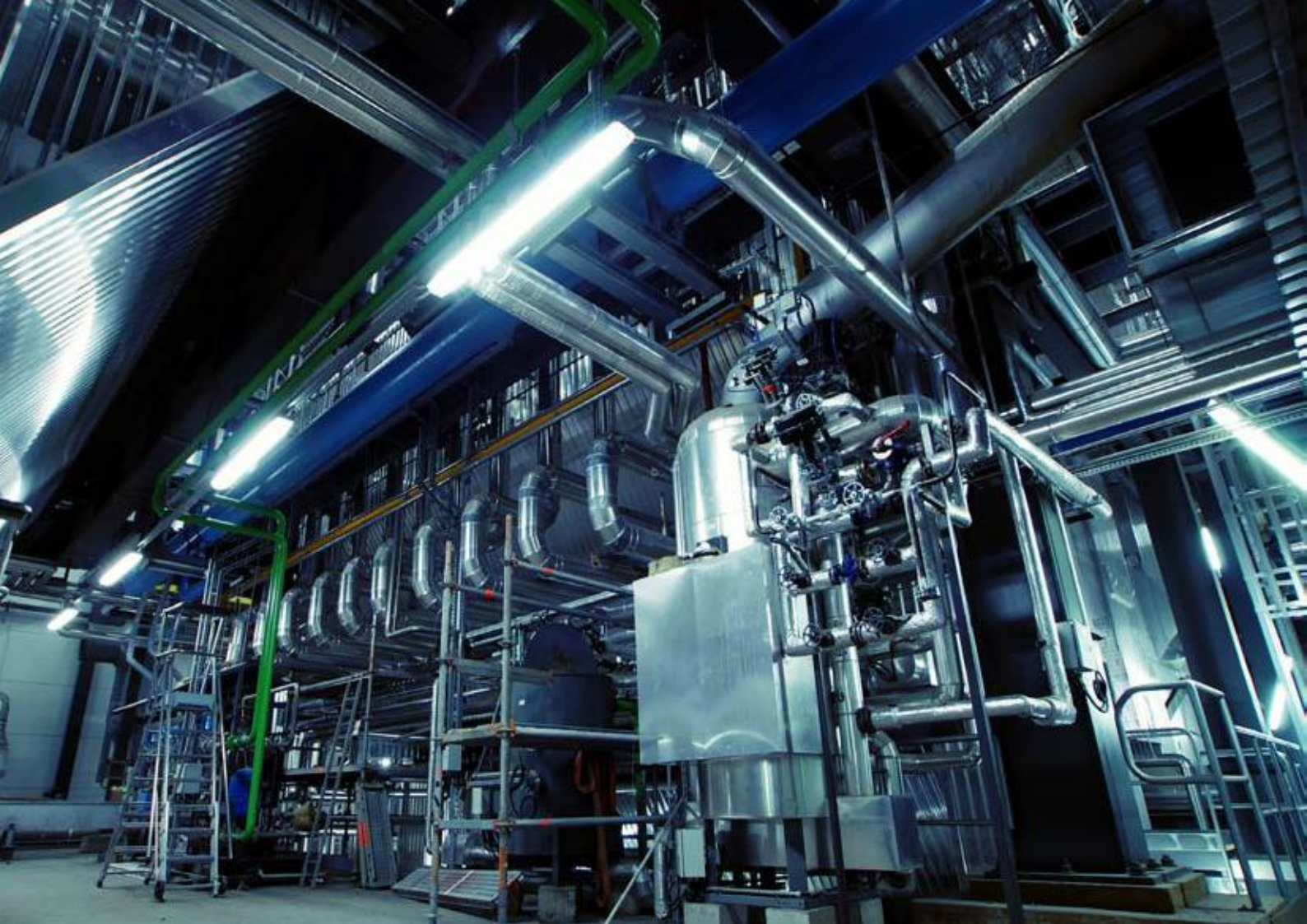

Lighting

Content

Page

Anodized fluorescent lighting fixtures

TNAML series

104

TNAML option

106

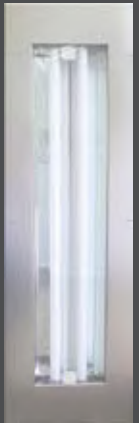



- 100% encapsulated, maintenance free design requiring only visual inspection to IEC/EN 60079-17
- 10 years operational warranty* assures favourable total cost of ownership
- Easy and flexible installation via slide guides
- Seawater resistant anodized aluminium (NORSOK 121)
- Tempered glass, very high impact resistant, IK10 (20 joules)
- High light output efficiency (>80%) - Less luminaires required for same lighting level
- Optional battery powered, 90/180 minutes functionality, battery functionality -40°C to +30°C - Emergency light by LEDs
- No condensation
- Self-cleaning glass
- Black start for unmanned platforms

TECHNICAL DATA

Material	Anodized aluminium seawater resistant in accordance with Norsok 121 Tempered glass high impact resistance
IP rating	IP68 according to EN/IEC 60529
Temperature range	-20°C ... +55°C -20°C ... +30°C for emergency function
Certificates	DEKRA 11ATEX0133 IECEX DEK11.0075
Marking	ATEX II 2 GD Ex e mb II T6 ... T5 Ex tD A21 T80°C ... T100°C IECEX II 2 GD Ex e mb IIC T6 ... T5 Ex tD A21 T80°C ... T100°C
Standards	ROHS 2002/95/EC REACH 2006/121/EC HACCP by DEKRA 06540-QUA/Ex
Impact rating	IK 10 (20 joules)
Visual inspection	Visual in accordance with EN 60079-17
Lamps	Pre-mounted long life, colour 4000K
Voltage	220-264 VAC 50/60Hz
Ballast	Electronic with end of life protection preheated start
Emergency batteries	Disconnecting possibility during installation by "B" terminal
Battery life time	300 cycles, automatic random, test each 100 days
Entries	2 x M25 cable glands
Vibration	According to IEC60721-2-3 Ed and IEC68-2-6 Frequency range: 1-150 Hz - Sweep rate: 1 octave per minute Amplitude: 5 mm (1 ... 10 Hz) - Sweep cycle: 10 Acceleration: 2 gn (10 ... 150 Hz) - Direction: 3

Total cost of ownership

The benefits of installing TNAML can be shown by using a Total Cost of Ownership tool. The calculation shows the LIFETIME COST SAVINGS using the data of the client.

Light distribution curve

Standard lighting

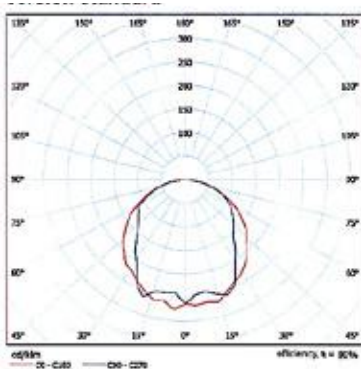

Emergency lighting

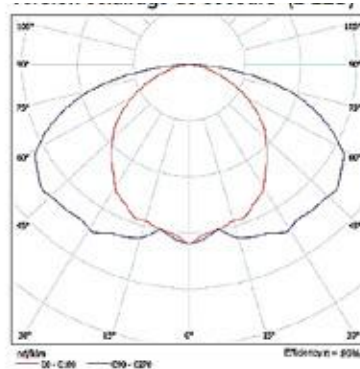

Outline dimensions (mm)

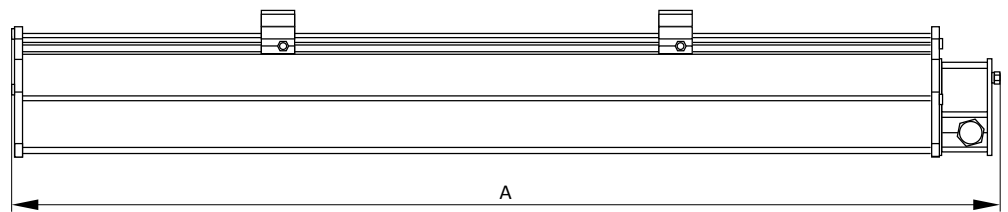
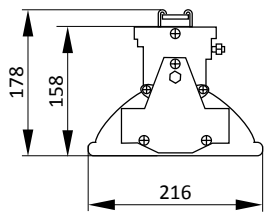

Product code	Zone of use	A (mm)	Emergency light	Watt	Voltage	Weight	Lumen
TNAMLG218	GAS 1 & 21	738	-	2 x 18 W	220-264 VAC	7.1 kg	2600
TNAMLG236	GAS 1 & 21	1348	-	2 x 36 W	220-264 VAC	9.7 kg	6000
TNAMLG258	GAS 1 & 21	1648	-	2 x 58 W	220-264 VAC	12.4 kg	10400
TNAMLD218	DUST 2 & 22	738	-	2 x 18 W	220-264 VAC	7.1 kg	2600
TNAMLD236	DUST 2 & 22	1348	-	2 x 36 W	220-264 VAC	9.7 kg	6000
TNAMLD258	DUST 2 & 22	1648	-	2 x 58 W	220-264 VAC	12.4 kg	10400
TNAMLG218-E1	GAS 1 & 21	898	90 minutes, 2 LEDs	2 x 18 W	220-264 VAC	9.4 kg	2600
TNAMLG218-E2	GAS 1 & 21	898	180 minutes, 2 LEDs	2 x 18 W	220-264 VAC	9.4 kg	2600
TNAMLG236-E1	GAS 1 & 21	1348	90 minutes, 2 LEDs	2 x 36 W	220-264 VAC	11.3 kg	6000
TNAMLG236-E2	GAS 1 & 21	1348	180 minutes, 2 LEDs	2 x 36 W	220-264 VAC	11.3 kg	6000
TNAMLG258-E1	GAS 1 & 21	1648	90 minutes, 2 LEDs	2 x 58 W	220-264 VAC	14.2 kg	10400
TNAMLG258-E2	GAS 1 & 21	1648	180 minutes, 2 LEDs	2 x 58 W	220-264 VAC	14.2 kg	10400
TNAMLD218-E1	DUST 2 & 22	898	90 minutes, 2 LEDs	2 x 18 W	220-264 VAC	9.4 kg	2600
TNAMLD218-E2	DUST 2 & 22	898	180 minutes, 2 LEDs	2 x 18 W	220-264 VAC	9.4 kg	2600
TNAMLD236-E1	DUST 2 & 22	1348	90 minutes, 2 LEDs	2 x 36 W	220-264 VAC	11.3 kg	6000
TNAMLD236-E2	DUST 2 & 22	1348	180 minutes, 2 LEDs	2 x 36 W	220-264 VAC	11.3 kg	6000
TNAMLD258-E1	DUST 2 & 22	1648	90 minutes, 2 LEDs	2 x 58 W	220-264 VAC	14.2 kg	10400
TNAMLD258-E2	DUST 2 & 22	1648	180 minutes, 2 LEDs	2 x 58 W	220-264 VAC	14.2 kg	10400

Options

Pole mounting brackets



Ceiling mounting brackets



Suspended mounting brackets



Frame for recessed installation in modular ceiling systems



Outline dimensions with wiring through 2 junction boxes

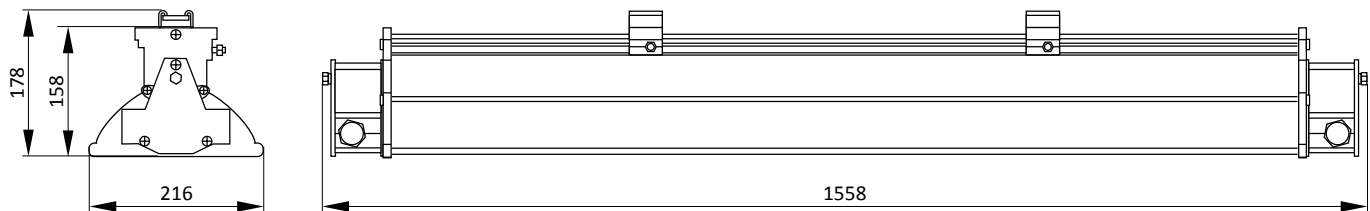

Options

Product code	Description
TNAML V1	110/120 VAC - 50/60 Hz - ONLY for 2 x 18 W and 2 x 36 W
TNAML L1	Lamp colour 3000K
TNAML L2	Lamp colour 6500K
TNAML E1	Electrical connection by 8 meter permanent flying lead, braided
TNAML M1	Pole mounting brackets
TNAML M2	Ceiling mounting brackets
TNAML M3	Suspended mounting brackets
TNAML M4	Frame in painted steel for recessed installation in modular ceiling systems
TNAML M5	Frame in stainless steel for recessed installation in modular ceiling systems
TNAML G1	Glass for use accordance with HACCP environment
TNAML G2	Frosted glass avoiding glare for low mounted fixtures
TNAML S1	Safety wire for installation into a fixing arrangement on the light fitting
TNAML S2	2 terminal boxes including through wiring 2.5 mm ²
TNAML B1	Black start emergency light - Wireless "Black Start" function for manned/unmanned functionality
TNAML C1	Ex e Cable gland (separate package)
TNAML H1	HACCP for food industry

Standard serie



Emergency light series

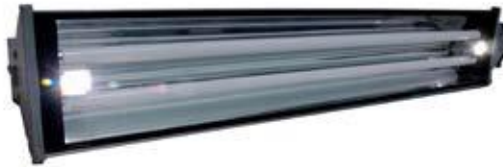

Sliding device for fast and easy mounting



Junction box





Sensors

Content

Page

Limit switches - Flameproof - Explosion gas group IIC

XCWD series - Assembled

110

ZCWD series - Unassembled

114

XC8J and ZC8J series

116

Limit switches - Increased safety

XCK and XCR series

118

Photocell - Flameproof - Explosion gas group IIC

XUWB series

124

Pressure switches - Flameproof - Explosion gas group IIC

XMLW series

126





The XCWD limit switches is a safe bet for controlling movement. It benefits from the latest developments: modularity, compactness, a very broad range of actuators.

They are designed for intensive use and a very good repeatability.

They are provided in complete assemblies or variable composition with:

- 2 or 4 electrically separate snap action contacts
- Heads that can be adjusted from 15° to 15° on 360° relative to the body
- can substitute the previous range XCWA and XCWF

TECHNICAL DATA

Material	Zamac
IP rating	IP66/67 according to EN/IEC 60529
Operating temperature	-20°C ... +60°C
Certificate	INERIS 03ATEX0083X
Marking	II 2 GD Ex d IIC T6 Gb Ex tb IIIC T85°C Db
Repeat accuracy	0.05 mm on the tripping points, with 1 million operation cycles for actuator with end plunger
Shock resistance	25 gn (18ms) according to IEC 60068-2-27
Vibration resistance	5 gn according to IEC 60068-2-27
Rated thermal current	6 A for 2 contacts according to versions, 3 A for 4 contacts
Rated insulation voltage	400 V according to IEC 60947-5-1
Contact blocks	Snap action - 1 x NC + 1 x NO or 2 x NC + 2 x NO
Resistance across terminals	≤ 25 mΩ according to IEC 60255-7 category 3
Electrical features of the contacts	<p>Switches with 2 contacts</p> <p>AC-15 ; C300 (Ue = 240 V, Ie = 1.5 A) DC-13 ; R300 (Ue = 250 V, Ie = 0.1 A)</p> <p>Switches with 4 contacts</p> <p>AC-15 ; C300 (Ue = 240 V, Ie = 0.75 A) DC-13 ; R300 (Ue = 250 V, Ie = 0.1 A)</p>

**Head with straight movement
Fixing by the body**



Actuator type	Metal end plunger		Steel roller plunger	
	2 contacts	4 contacts	2 contacts	4 contacts
1 m cable length	XCWD2110L1	XCWD4110L1	XCWD2102L1	XCWD4102L1
2 m cable length	XCWD2110L2	XCWD4110L2	XCWD2102L2	XCWD4102L2
5 m cable length	XCWD2110L5	XCWD4110L5	XCWD2102L5	XCWD4102L5
10 m cable length	XCWD2110L10	XCWD4110L10	XCWD2102L10	XCWD4102L10

**Head with straight movement
Fixing by the head**



Actuator type	Metal end plunger - M12		Steel roller plunger - M12	
	2 contacts	4 contacts	2 contacts	4 contacts
1 m cable length	XCWD21F0L1	XCWD410L1	XCWD21F2L1	XCWD41F2L1
2 m cable length	XCWD21F0L2	XCWD410L2	XCWD21F2L2	XCWD41F2L2
5 m cable length	XCWD21F0L5	XCWD410L5	XCWD21F2L5	XCWD41F2L5
10 m cable length	XCWD21F0L10	XCWD410L10	XCWD21F2L10	XCWD41F2L10

**Head with angular movement
Fixing by the body**





Actuator type	Thermoplastic roller lever		Steel roller lever	
	2 contacts	4 contacts	2 contacts	4 contacts
1 m cable length	XCWD2115L1	XCWD4115L1	XCWD2116L1	XCWD4116L1
2 m cable length	XCWD2115L2	XCWD4115L2	XCWD2116L2	XCWD4116L2
5 m cable length	XCWD2115L5	XCWD4115L5	XCWD2116L5	XCWD4116L5
10 m cable length	XCWD2115L10	XCWD4115L10	XCWD2116L10	XCWD4116L10

**Head with angular movement
Fixing by the body**



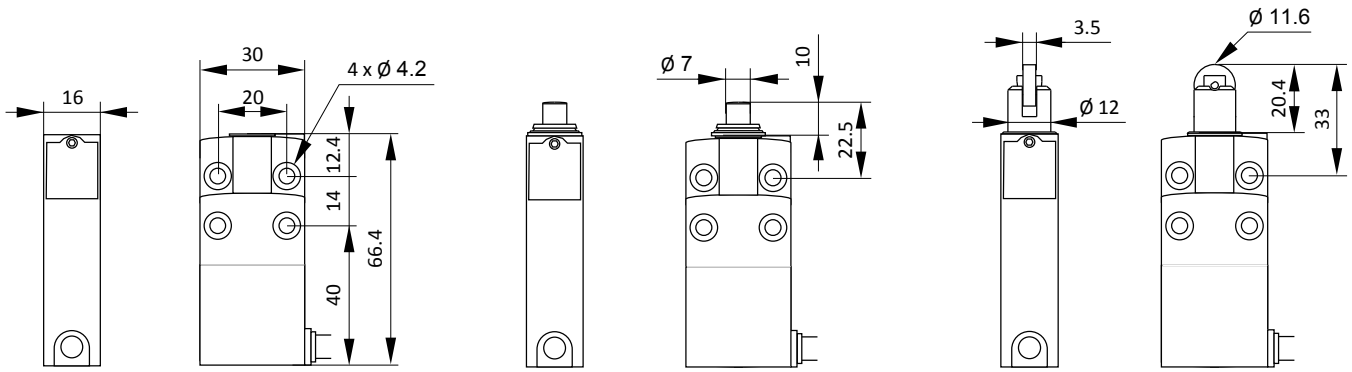

Actuator type	Lever variable length with thermoplastic roller		Lever variable length with steel roller	
	2 contacts	4 contacts	2 contacts	4 contacts
1 m cable length	XCWD2145L1	XCWD4145L1	XCWD2146L1	XCWD4146L1
2 m cable length	XCWD2145L2	XCWD4145L2	XCWD2146L2	XCWD4146L2
5 m cable length	XCWD2145L5	XCWD4145L5	XCWD2146L5	XCWD4146L5
10 m cable length	XCWD2145L10	XCWD4145L10	XCWD2146L10	XCWD4146L10



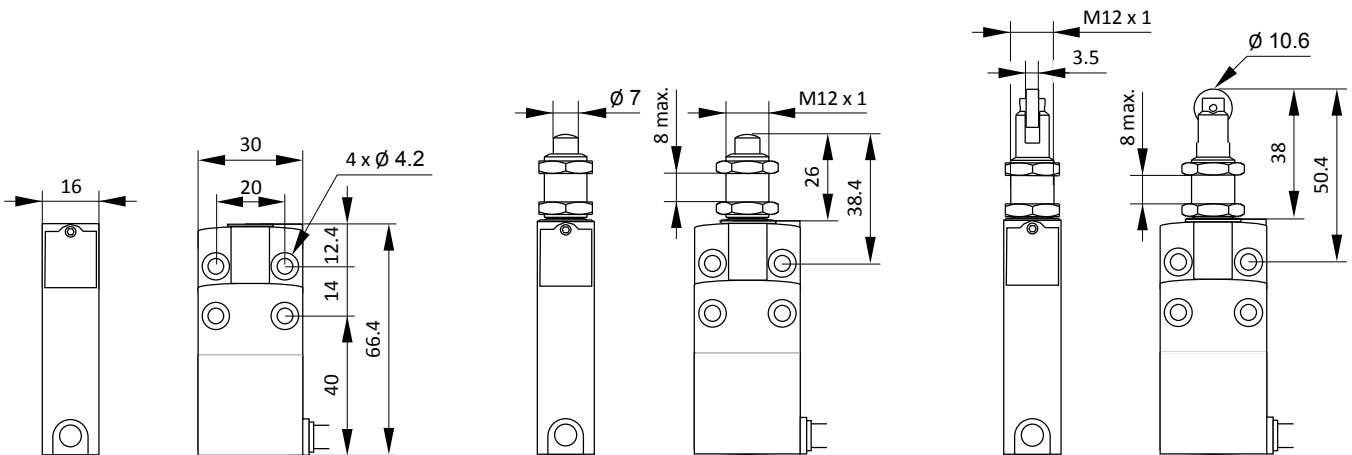

Switch actuation	On end 	By 30° cam 
Maximum actuation speed	0.5 m/s	0.5 m/s
Mechanical durability	10 million operating cycles	
Minimum force or torque	for tripping	8.5 N
	for positive opening	42.5 N
Cabling	PvR cable: 5 x 0.75 mm ² for 2-pole contact versions, 9 x 0.34 mm ² for 4-pole contact versions	

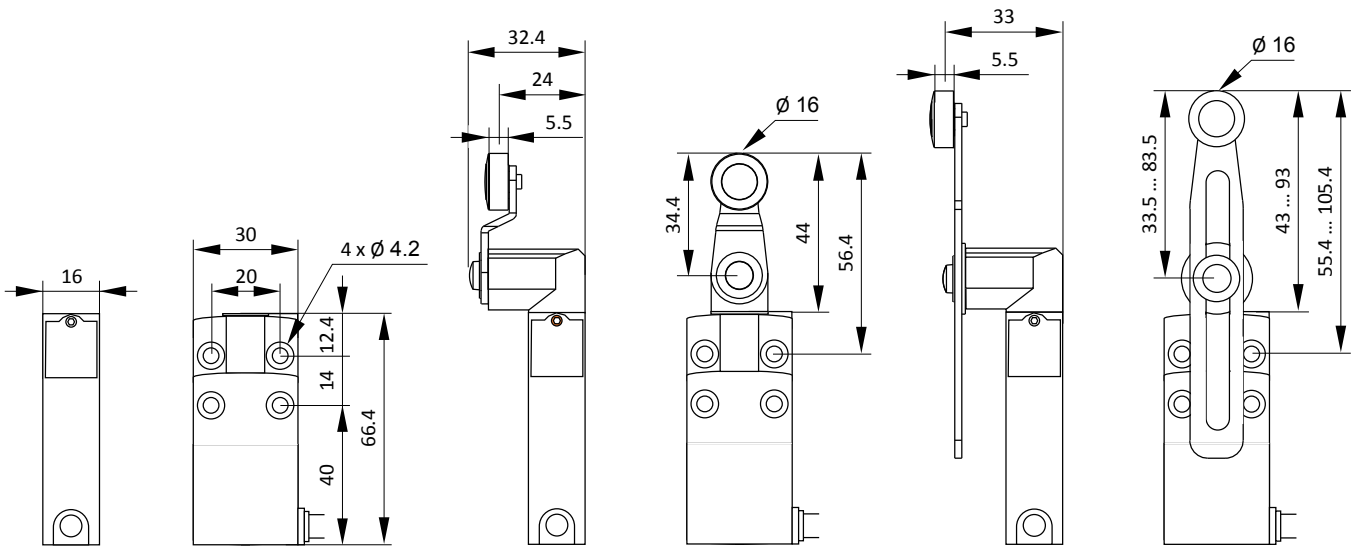

Switch actuation	On end 	By 30° cam 
Maximum actuation speed	0.5 m/s	0.1 m/s
Mechanical durability	10 million operating cycles	
Minimum force or torque	for tripping	8.5 N
	for positive opening	42.5 N
Cabling	PvR cable: 5 x 0.75 mm ² for 2-pole contact versions, 9 x 0.34 mm ² for 4-pole contact versions	



Switch actuation	By 30° cam 	By 30° cam 	
Maximum actuation speed	0.1 m/s	1.5 m/s	
Mechanical durability	10 million operating cycles		
Minimum force or torque	for tripping	7 N	0.1 N.m
	for positive opening	35 N	0.5 N.m
Cabling	PvR cable: 5 x 0.75 mm ² for 2-pole contact versions, 9 x 0.34 mm ² for 4-pole contact versions		

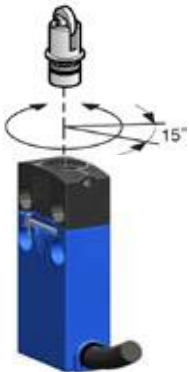

All actuators can be adjusted from 15° to 15° on 360° relative to the body

Contacts blocks

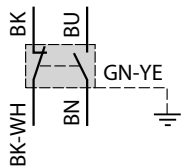

Switches with 2-pole contacts
NC + NO
snap action

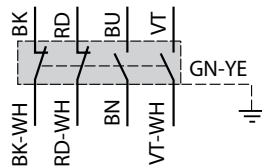

Switches with 4-pole contacts
NC + NC + NO + NO
snap action

Variable components - Actuator and body unassembled

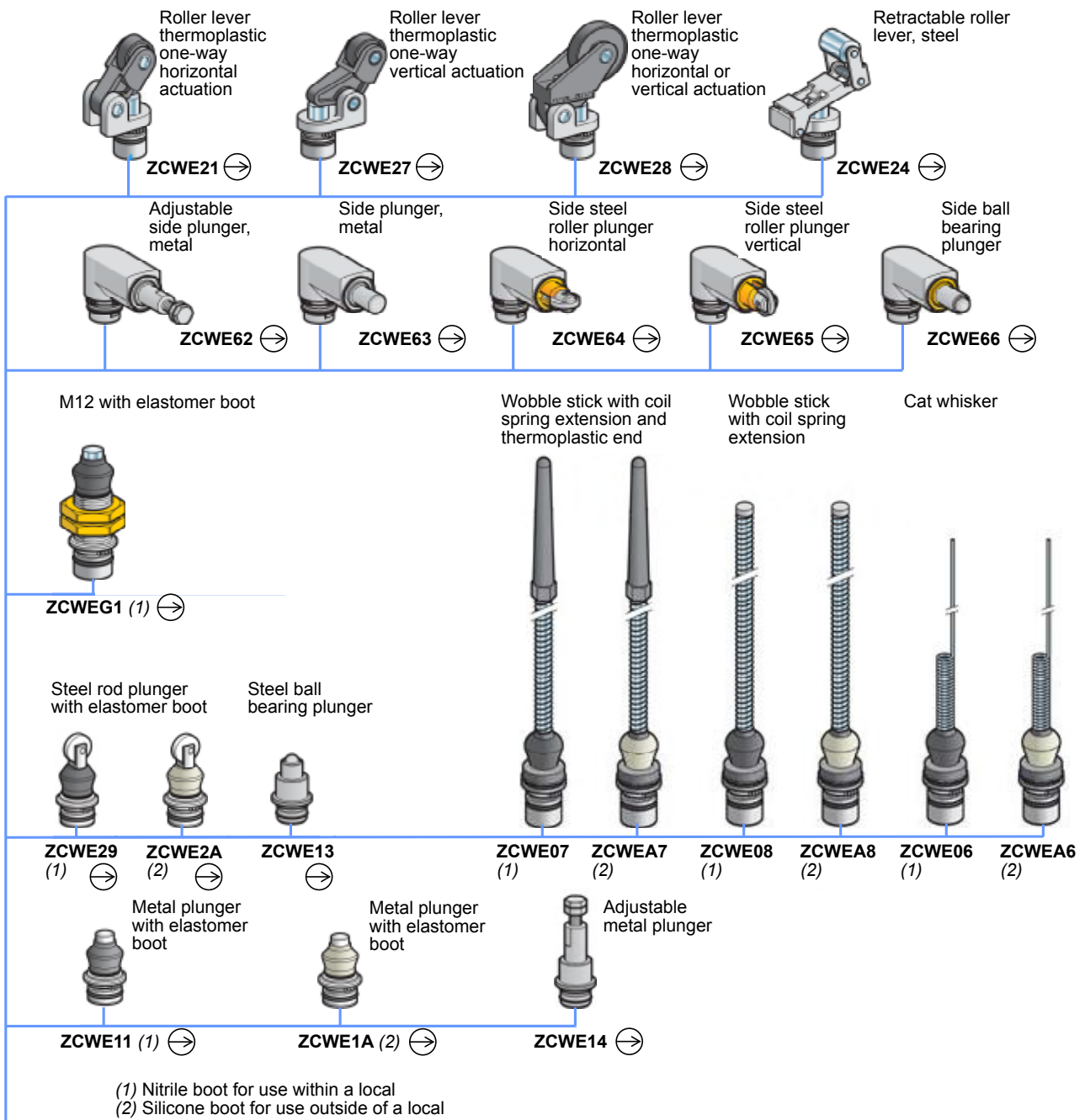

Part number of the body - When ordering specify the selected actuator

Cable length	2 contacts (1NC + 1NO)	4 contacts (2NC + 2NO)
1 m long	ZCWD21L1	ZCWD41L1
2 m long	ZCWD21L2	ZCWD41L2
5 m long	ZCWD21L5	ZCWD41L5
10 m long	ZCWD21L10	ZCWD41L10

Snap action contacts



Variable components - Actuator, head and body unassembled

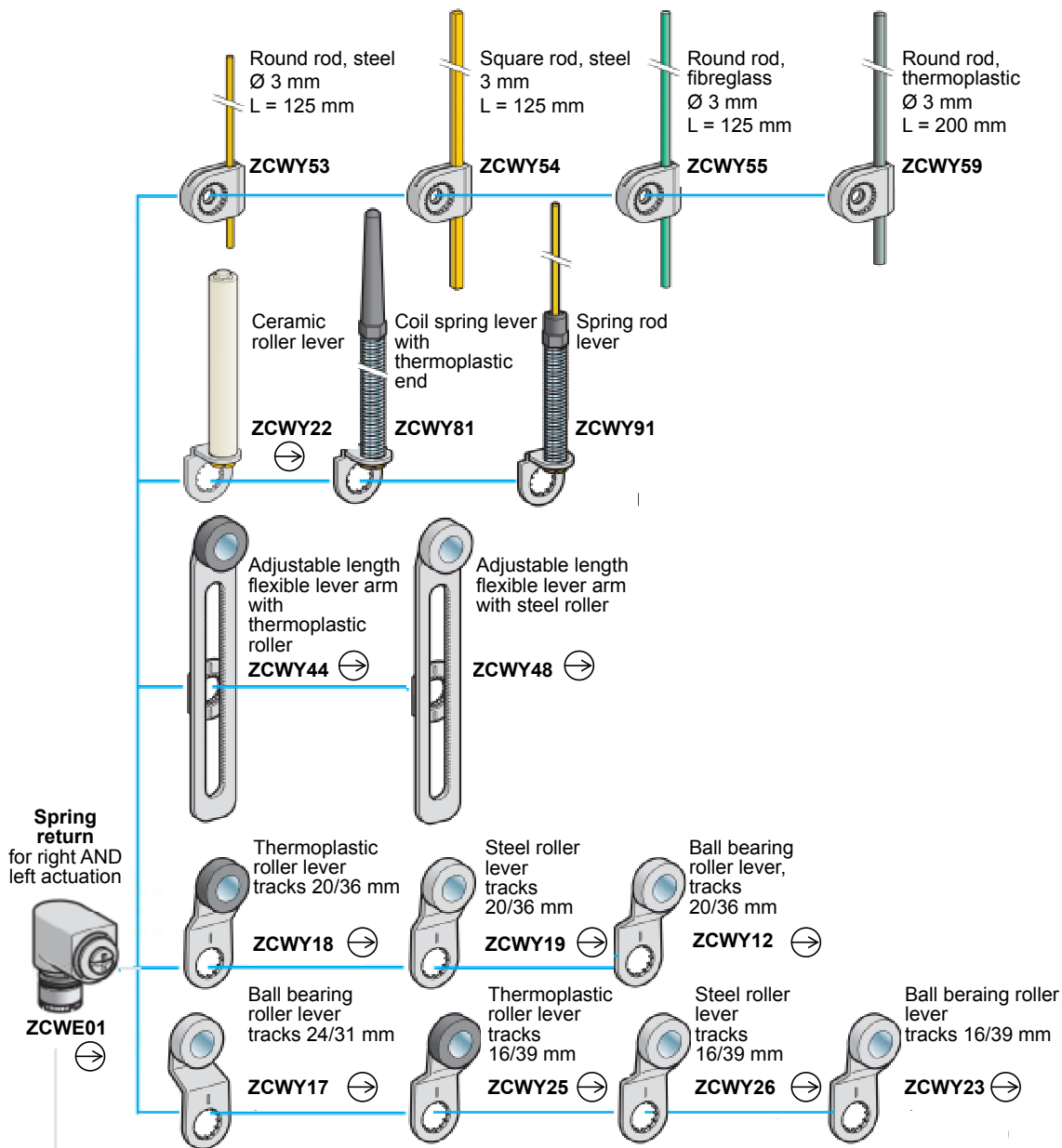

Part number of the body - When ordering specify the selected actuator

Cable length	2 contacts (1NC + 1NO)	4 contacts (2NC + 2NO)
1 m long	ZCWD21L1	ZCWD41L1
2 m long	ZCWD21L2	ZCWD41L2
5 m long	ZCWD21L5	ZCWD41L5
10 m long	ZCWD21L10	ZCWD41L10

Snap action contacts





The XC8JC and ZC8JC, made in cast iron, are extremely robust and reliable.

Their high performances added to the very important choice of actuators make them suitable in many applications.

For special applications, the heads can be designed according to the needs.

TECHNICAL DATA

Material	Painted cast iron
IP rating	IP66/67 according to EN/IEC 60529
Temperature range	-20°C or - 50°C ... +60°C or +80°C
Certificate	INERIS 03ATEX0123
Marking	II 2 GD Ex d IIC T6 ... T5 Gb Ex tb IIIC T85°C ... T100°C Db
Rated thermal current	6 A
Insulation voltage	500 V
Contact block	1 x O+C - 1 pole snap-action contact
Resistance between terminals	≤ 25 mΩ
Power use	Category: AC11, DC11
Mechanical durability	10 million of operation cycles



XC8JC161P1

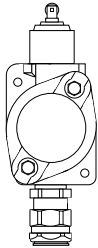

XC8-JC162P1

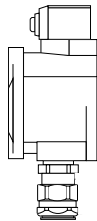

XC8-JC163P1

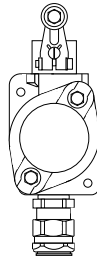

XC8JC10111P1
XC8JC10511P1

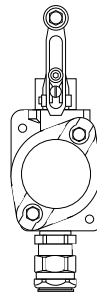

XC8JC10131P1
XC8JC10531P1

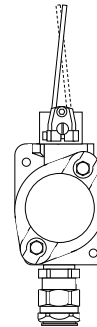

XC8JC10151P1

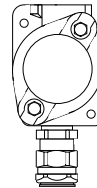

ZC8JC1P1
ZC8JC2P1
ZC8JC4P1

Product code	Actuators with straight movement		Add the cable entry codes according to (6)			Weight (kg)
XC8JC161P1	Steel plunger (1)		•	•	•	2
XC8JC162P1	Roller plunger (2)		•	•	•	2
XC8JC163P1	Side plunger (2)		•	•	•	2
Product code	Heads with angular movement	Actuation direction	Add the cable entry codes according to (6)			
XC8JC10111P1	Thermoplastic roller lever (3)	Actuation from left and right	•	•	•	2,2
XC8JC10511P1		Actuation from left or right (5)	•	•	•	2,2
XC8JC10131P1	Variable length (3)	Actuation from left and right	•	•	•	2,2
XC8JC10531P1		Actuation from left or right (5)	•	•	•	2,2
XC8JC10151P1	Steel rod (4)	Actuation from left and right	•	•	•	2,2
XC8JC10551P1	3 mm, length: 125 mm	Actuation from left or right (5)	•	•	•	2,2
ZC8JC1P1	Limit switch body only for plunger and rotary heads for plunger and rotary heads	1 contact "OC"	•	•	•	2,2
ZC8JC2P1		2 x "OC", simultaneous	•	•	•	2,2
ZC8JC4P1		1 contact "OC" + 1 contact "OC", 2 steps	•	•	•	2,2
Cable entry code (6)			Codes below to add to the product code			
Thread M20		1F for no-armoured cable with clamping device 4F for armoured cable Without cable gland	1	I	C	
			4	I		
			5			

(1) Actuation on end. Maximum actuation speed: 0.5 m/s

(2) Actuation by cam 30°. Maximum actuation speed: 0.5 m/s

(3) Actuation by cam 30°. Maximum actuation speed: 1.5 m/s

(4) Actuation by cylindrical finger. Maximum actuation speed: 1.5 m/s

(5) By adjusting the operating head

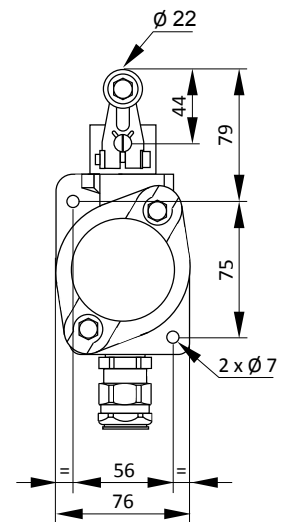
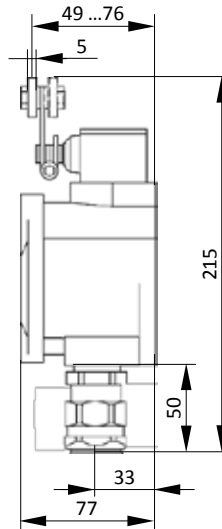
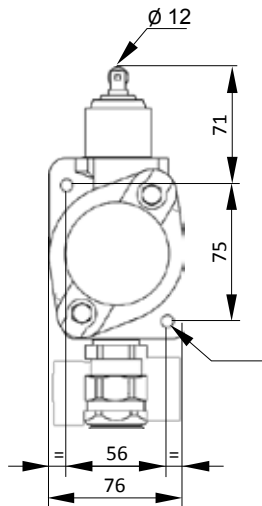
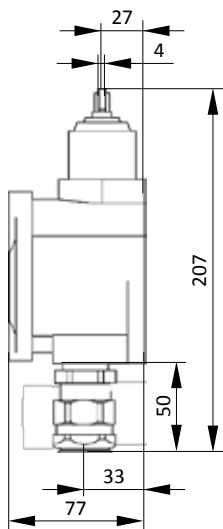



This extensive range of products and components is well known worldwide for its reliability, its design and the many opportunities in the choice of heads.

They allow the customers to implement and operate them in numerous places of their process.

TECHNICAL DATA

Material (body)	Zamac
IP rating	IP65 according to EN/IEC 60529
Temperature range	XCKW: -40°C ... +60°C XCR.W: -30°C ... +60°C
Certificates	INERIS 03ATEX0038X INERIS 03ATEX0039X IECEX INE 12.0029X IECEX INE 12.0030X
Marking	II 2 GD Ex d e IIC T6 Gb Ex tb IIIC T85°C Db
Contact block	500 V, 3A

For lifting equipment, conveyors, handling devices
Fixing distance 61.5 mm



Actuator type	Metallic rods in cross	Metallic rods in cross, reversed head
Two 2-pole NC + NC	XCKWMMR54D1H29	XCKWMMR54D2H29
Actuation speed	1.5 m/s	
Mechanical durability	2 million operations	
Contact type	Staggered, slow break	
Cable entry	2 entries with blind plug, 1 entry with cable gland ISO M20 for cable Ø 8 to 13mm	

For lifting equipment, conveyors
Fixing distance 85 x 75 mm

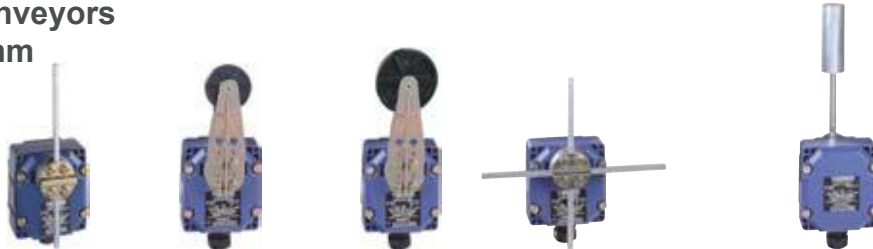

Actuator type	Square rod 6 mm spring return position	Thermoplastic roller lever Ø 30 mm	Thermoplastic roller lever Ø 50 mm	Metallic square rod in cross, stay put	Conveyor belt shift monitoring Lever galvanized	Lever in stainless steel
Two 2-pole NC + NO contacts, both operate in each direction	XCRAW111	XCRAW121	XCRAW151	XCREW181 (2)		
Two 2-pole NC + NO contacts, one operates in each direction	XCRBW111	XCRBW121	XCRBW151	XCRFW171 (3)		
2 single contacts "O + C"					XCRTW115	XCRTW215
Actuation speed	1.5 m/s					
Mechanical durability	10 million operations				0.3 million operations	
Contact type	Snap action					
Cable entry	1 entry ISO M20 for cable of Ø 8 to 13 mm					

(2) Metallic rods in cross
 (3) Metallic rods in "T"

Overall use
Fixing distance 41 mm



Actuator type	Metal end plunger	Steel roller plunger	Thermoplastic roller lever	Thermoplastic roller lever	"Cat's whisker"
NO + NC	XCKWM2110H29	XCKWM2102H29	XCKWM2121H29	XCKWM2115H29	XCKWM2106H29
Actuation speed	0.5 m/s		1.5 m/s		0.5 m/s
Mechanical durability	20 million operations				10 million operations
Contact type	Snap action				
Cable entry	2 entries with blind plug, 1 entry with cable gland ISO M20 for cable Ø 8 to 13mm				

Compact range Fixing distance 20 mm



Actuator type	Metal end plunger	Booted metal end plunger	Steel roller plunger	Plastic roller, horizontal actuation	Plastic roller, vertical actuation	Plastic roller, vertical or horizontal actuation
NC + NC	XCKWD2110P16	XCKWD2111P16	XCKWD2102P16	XCKWD2121P16	XCKWD2127P16	XCKWD2128P16
NO + NC	XCKWD2910P16	XCKWD2911P16	XCKWD2902P16	XCKWD2921P16	XCKWD2927P16	XCKWD2928P16
Actuation speed	0.5 m/s			1 m/s		
Durability	15 million operations		10 million operation	15 million operations		
Type of contact	Snap action					
Cable entry	1 entry M16 for cable Ø 5 to 8 mm					

Compact range Fixing distance 20mm



Actuator type	Thermoplastic roller lever	Thermoplastic roller lever Ø 50 mm	Variable length plastic roller lever	Variable length plastic roller Ø 50 mm	"Cat's whisker"	M18 head Metal end plunger	M18 steel roller end plunger
NO + NC	XCKWD2118P16	XCKWD2139P16	XCKWD2145P16	XCKWD2149P16	XCKWD2106P16	XCKWD21H0P16	XCKWD21H2P16
NO + NC	XCKWD2918P16	XCKWD2939P16	XCKWD2945P16	XCKWD2949P16	XCKWD2906P16	XCKWD29H0P16	XCKWD29H2P16
Actuation speed	1.5 m/s				1 m/s	0.5 m/s	
Durability	10 million operations				5 million	10 million operations	
Type of contact	Snap action						
Cable entry	1 entry ISO M16 for cable Ø 5 to 8 mm						

Compact range Fixing distance 30 x 60 mm



Actuator type	Metal end plunger	Steel roller plunger	Steel roller lever	Thermoplastic roller lever	Variable length thermoplastic roller lever	Round lever Ø 6 mm polyamide L = 200 mm
Contact NO + NC	XCKWJ2161H29	XCKWJ2167H29	XCKWJ210513H29	XCKWJ210511H29	XCKWJ210541H29	XCKWJ210559H29
Actuation speed	0.5 m/s	1 m/s	1.5 m/s			
Durability	30 million operations	25 million operation	30 million operations		20 million operations	
Type of contact	Snap action					
Cable entry	1 entry ISO M20 for cable Ø 8 to 13 mm					

XCKWD - Compact range

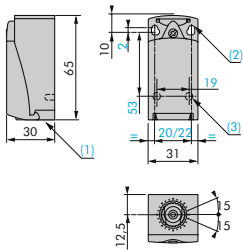

ZCE06

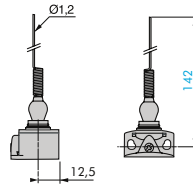

- 1) 1 entry ISO M16 x 1.5 for cable gland
- 2) 2 slotted holes $\varnothing 4.3 \times 6.3$ mm and fixing distance 22 mm or 2 holes $\varnothing 4.3$ mm and fixing distance 20 mm
- 3) 2 holes for mounting $\varnothing 3$ mm, depth 4 mm

ZCE10

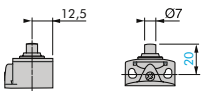

ZCE11

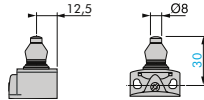

ZCE02

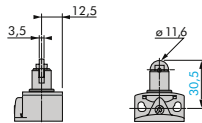

ZCE21

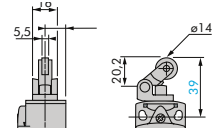

ZCE27

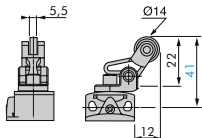

ZCE28

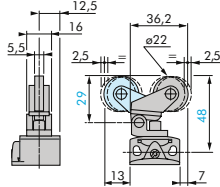

ZCEH0

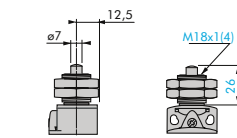

ZCEH2

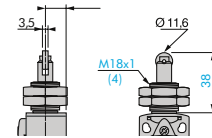

4) Screw of 3,5 mm

ZCE01 + ZCY18

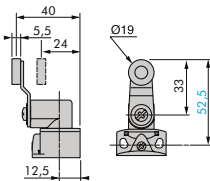

ZCE01 + ZCY45

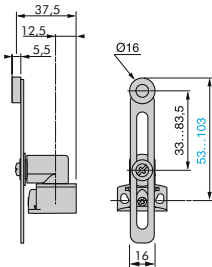

ZCEH01 + ZCY39

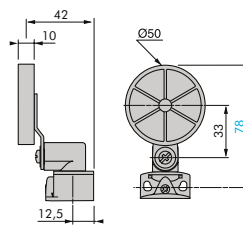

ZCE01 + ZCY49

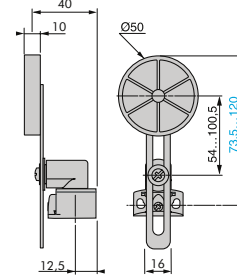

XCKWJ - Classique range

XCKWJ2161H29

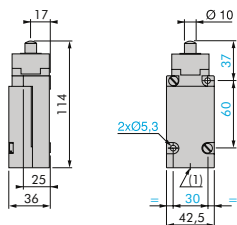

XCKWJ2167H29

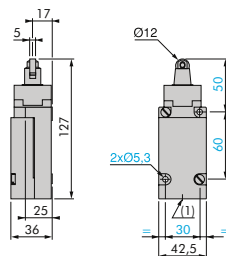

XCKWJ210513H29
XCKWJ210511H29

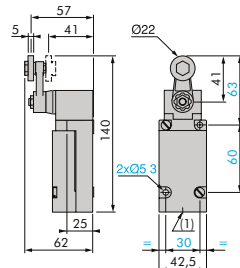

XCKWJ210541H2

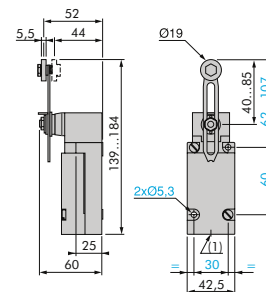

XCKWJ210559H29

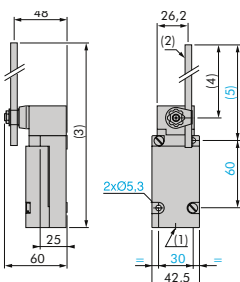

- 1) 1 entry ISO M20 x 1.5 for cable gland
- 2) Lever $\varnothing 6$ mm, length 120 mm
- Ø) 2 slotted holes 5.3×7.3 mm

XCKWMR, XCRA/B/TW

XCKWMR54D1H29 / XCKWMR54D2H29

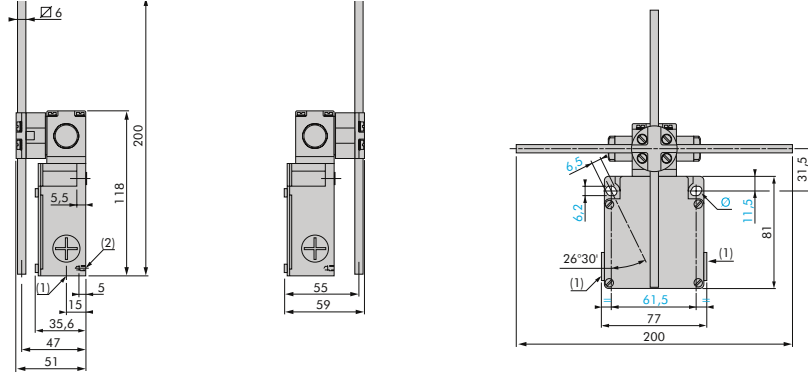

- 1) 3 entries ISO M20 x 1.5 for cable gland
- 2) 2 centring holes \varnothing 3.9 mm
- Ø) 2 slotted holes 6.2 x 6.5 mm

XCRAW111
XCRBW111

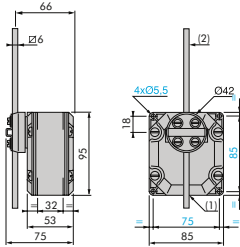

XCRAW121
XCRBW121

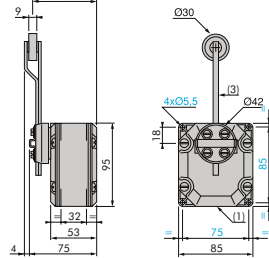

XCRAW151
XCRBW151

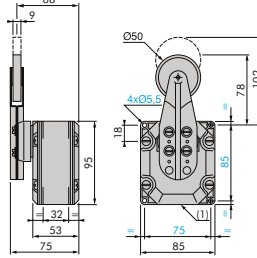

XCREW181
XCREW171

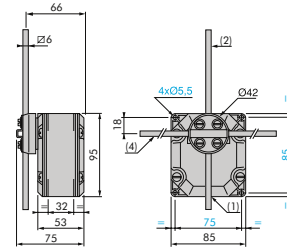

XCRTW115 / XCRTW215

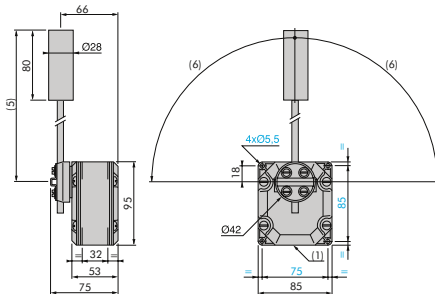

Fixing

Horizontal position

Vertical position

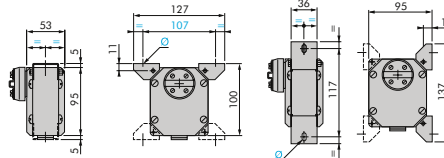

- 1) 1 entry ISO M20 x 1.5 for cable gland
- 2) Lever length: 200 mm
- 3) Lever length + roller: 160 mm
- 4) Lever length: 300 mm for XCRPW and 200 mm for XCREW
- 5) Max: 200 mm - Min: 83 mm
- 6) Max: 90°
- Ø) 2 slotted holes 6.2 x 6.5 mm

XCKWM - Classique range

XCKWM2110H29

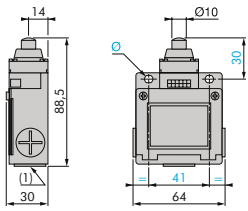

XCKWM2102H29

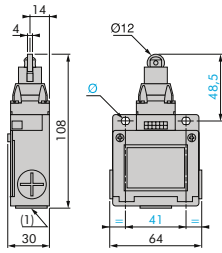

XCKWM2121H29

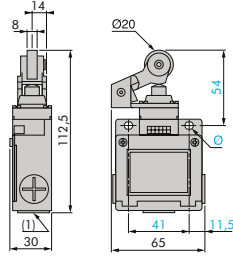

XCKWM2115H29

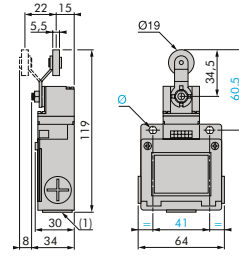

XCKWM2106H29

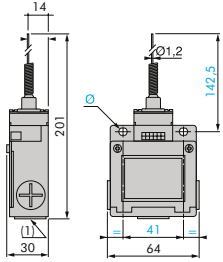

arrière

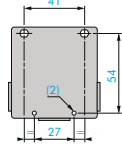

- 1) 3 entries ISO M20 x 1.5 for cable gland
- 2) 2 holes x Ø 4
- Ø) 2 slotted holes 5.2 x 6.2 mm



With a footprint diameter of only 30 mm these prewired photocells, certified ATEX Ex d, can be used in all types of applications and processes.

With a nominal range from 0.6 m to 15 m, it will be able to meet all needs.

TECHNICAL DATA

Material	Brass nickel plated or stainless steel AISI 316L
IP rating	IP67 according to EN/IEC 60529
Temperature range	-25°C ... +55°C
Certificate	INERIS 06ATEX0066X
Marking	II 2 GD Ex d IIC T6 Gb Ex tb IIIC T85°C Db
Type of transmission	Infrared
Supply voltage	12 ... 24 VDC with protection against reverse polarity
Current consumption	35 mA
Maximum switching frequency	500 Hz
Electrical connection	By cable 2 m for XUWB...L2 By cable 5 m for XUWB...L5
Fixing diameter	M30 x 1.5

Type of detection	Reflex polarized	Reflex	Barrier
Type of output in DC circuit (static output) Product code			
PNP OUTPUT - NO	XUWB9APANL2	XUWB1APANL2	XUWB2APANL2R
PNP OUTPUT - NC	XUWB9APBNL2	XUWB1APBNL2	XUWB2APBNL2R
NPN OUTPUT - NO	XUWB9ANANL2	XUWB1ANANL2	XUWB2ANANL2R
NPN OUTPUT - NC	XUWB9ANBNL2	XUWB1ANBNL2	XUWB2ANBNL2R
Transmitter to add	-	-	XUWB2AKSNL2T
Rated operating distance in meter	2	4	15

For a length of 5m, replace L2 by L5. Example: XUWB5APANL2 becomes XUWB5APANL5

Reflector code	Size
XUZC16	Standard reflector Ø 16
XUZC21	Standard reflector Ø 21
XUZC31	Standard reflector Ø 31
XUZC39	Standard reflector Ø 39
XUZC24	Reflector for short sensing ranges 24 x 21

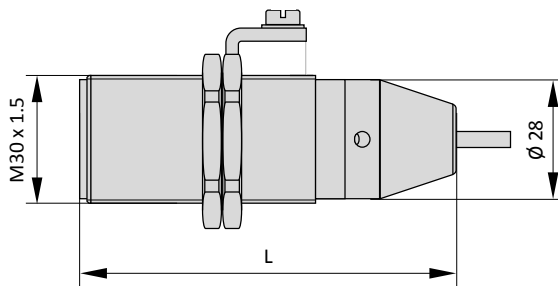

Standard reflector

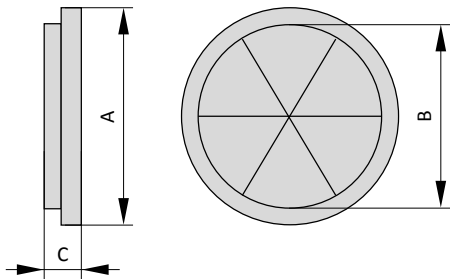

Reflector for short distance of detection

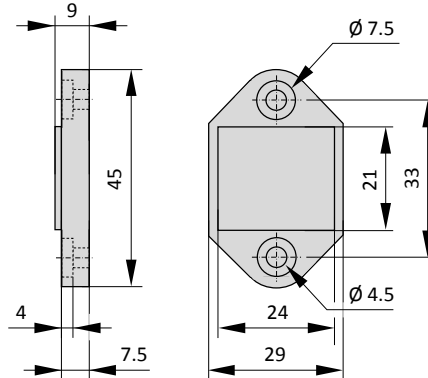



With a wide range of pressures, from 0.1 to 500 bars, the XMLW pressure switches allow to control fluids in hazardous areas.

They meet the highest level of protection for the explosive atmospheres.

TECHNICAL DATA

Material	Zamac
IP rating	IP66 according to EN/IEC 60529
Temperature range	-20°C ... +60°C
Certificate	INERIS 04ATEX0007
Marking	For Tfluid < +65°C II 2 GD Ex d e IIC T6 Gb Ex tb IIIC T85°C Db
Rated thermal current	6 A
Insulation voltage	250 V
Contact block	Single-pole snap action NO+NC
Electrical connection	Screw terminal block, cable entry ISO M20 for cable Ø 8 to 13 mm
Short circuit protection	By fuse 6 A gG (gl) to be installed outside the Ex area
Hydraulic connection	1/4" gas female - Other on request

XMLW-C010/C020/035/070/160/300/500

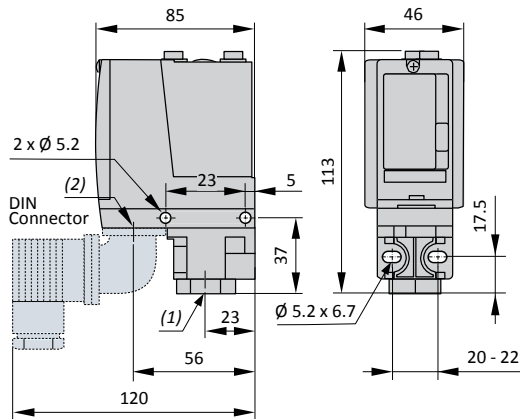

XMLW-C001

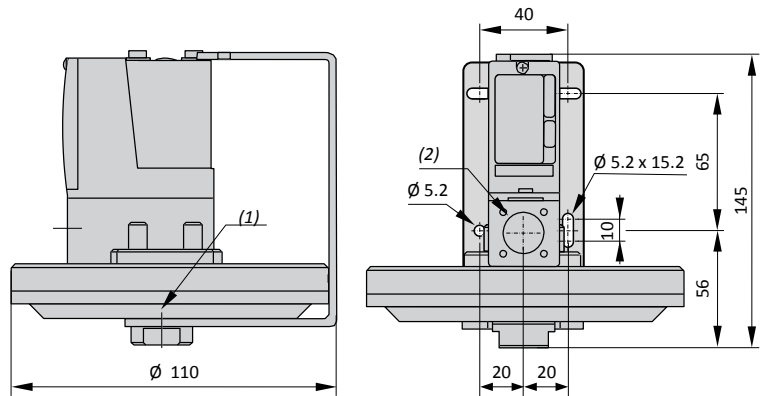

XMLW-CM02T2S12, XMLW-C004B2S12, XMLW-C004C2S12

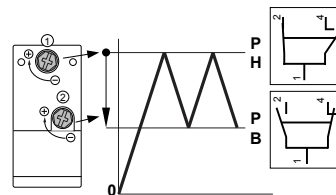
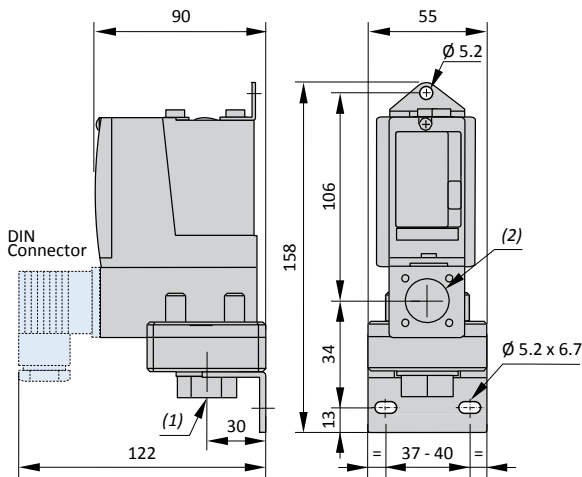

**XMLW-C004B2S12,
XMLW-C004C2S12,
XMLW-C010 / C020 / 035
XMLW-070 / 160 / 300 / 500
XMLW-C001**

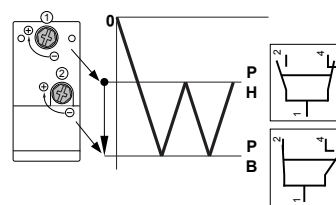

XMLW-CM02T2S12

(1) Fluid entry G 1/4"
(2) Electrical connection M20 x 1.5

Pressure switch with display	Gauge	Setting range upper threshold (ph)	Fluids controlled	Possible differential (add to PB to get PH)		
				Min. low setting	Min. high setting	Max. high setting
XMLW-CM02T2S12	- 1 bar	- 1 ... - 0.14 bar	Hydraulic oils, water, air	0.13 bar	0.14 bar	0.8 bar
XMLW-C001R2S12	1 bar	0.05 ... 1 bar	Hydraulic oils, air	0.03 bar	0.04 bar	0.8 bar
XMLW-C001S2S12	1 bar	0.005 ... 1 bar	Water, corrosives fluids	0.03 bar	0.04 bar	0.8 bar
XMLW-C004B2S12	4 bar	0.3 ... 4 bar	Hydraulic oils, water, air	0.17 bar	0.15 bar	2.5 bar
XMLW-C004C2S12	4 bar	0.3 ... 4 bar	Corrosive fluids	0.17 bar	0.15 bar	2.5 bar
XMLW-C010B2S12	10 bar	0.7 ... 10 bar	Hydraulic oils, water, air	0.45 bar	0.70 bar	8 bar
XMLW-C010C2S12	10 bar	0.7 ... 10 bar	Corrosive fluids	0.45 bar	0.70 bar	8 bar
XMLW-C020B2S12	20 bar	1.3 ... 20 bar	Oil, water, air	0.7 bar	1 bar	11 bar
XMLW-C020C2S12	20 bar	1.3 ... 20 bar	Corrosive fluids	0.7 bar	1 bar	11 bar
XMLW-C035B2S12	35 bar	3.5 ... 35 bar	Hydraulic oils, water, air	1 bar	1.5 bar	22 bar
XMLW-C035C2S12	35 bar	3.5 ... 35 bar	Corrosive fluids	1 bar	1.5 bar	22 bar
XMLW-C070D2S12	70 bar	7 ... 70 bar	Hydraulic oils, air	4.5 bar	8.9 bar	60 bar
XMLW-C070E2S12	70 bar	7 ... 70 bar	Fresh water, sea water	4.5 bar	8.9 bar	60 bar
XMLW-C070N2S12	70 bar	7 ... 70 bar	Corrosive fluids	4.5 bar	8.9 bar	60 bar
XMLW-C160D2S12	160 bar	12 ... 160 bar	Hydraulic oils, air	9 bar	21 bar	110 bar
XMLW-C160E2S12	160 bar	12 ... 160 bar	Fresh water, sea water	9 bar	21 bar	110 bar
XMLW-C160N2S12	160 bar	12 ... 160 bar	Corrosive fluids	9 bar	21 bar	110 bar
XMLW-C300D2S12	300 bar	22 ... 300 bar	Hydraulic oils, air	16 bar	35 bar	240 bar
XMLW-C300E2S12	300 bar	22 ... 300 bar	Fresh water, sea water	16 bar	35 bar	240 bar
XMLW-C300N2S12	300 bar	22 ... 300 bar	Corrosive fluids	16 bar	35 bar	240 bar
XMLW-C500D2S12	500 bar	30 ... 500 bar	Hydraulic oils, air	19 bar	52 bar	340 bar
XMLW-C500E2S12	500 bar	30 ... 500 bar	Fresh water, sea water	19 bar	52 bar	340 bar
XMLW-C500N2S12	500 bar	30 ... 500 bar	Corrosive fluids	19 bar	52 bar	340 bar

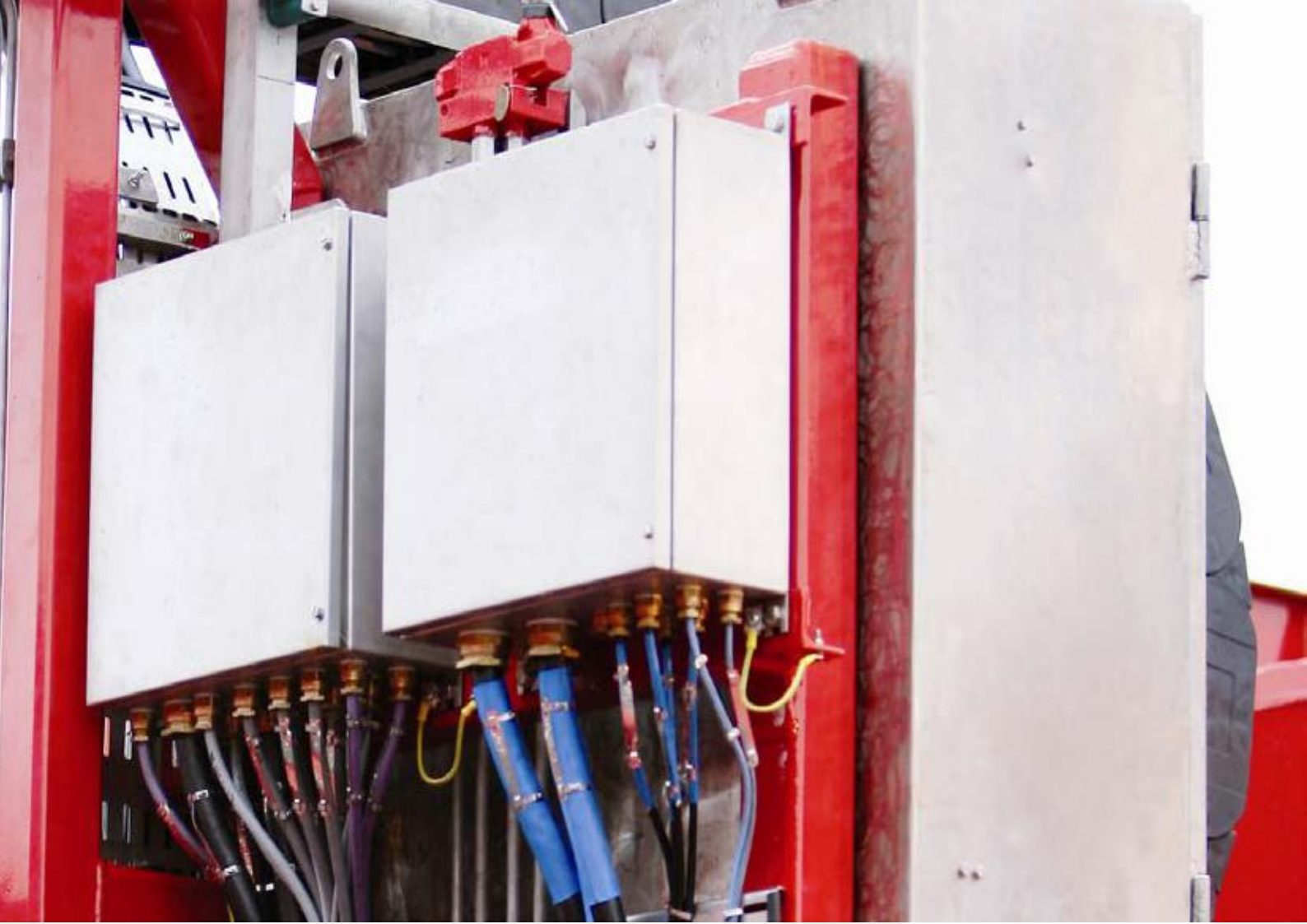

Cable glands

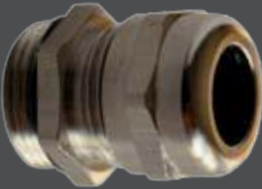

Content

Page

Increased safety

Polyamide TRCG series

130

Brass nickel-plated TRCG series

132



Polyamide cable glands with metric threads for use with increased safety Ex e enclosure.

TECHNICAL DATA

Material	Polyamide
IP rating	IP68
Temperature range	-35°C ... +95°C
Certificate	LCIE 07ATEX6082X
Marking	Ex e (black colour) or Ex i (blue colour)
Gasket	Included
Threads	Metric - PG and NPT on request
Accessories	Lock nut, Gasket

Product code		Thread Ø M	Clamping range	E	L	H	Packing	Lock nut to order separately
Ex e (noir)	Ex i (bleu)							
TRCG12M16099	TRCG12M16095	M16	5.0 - 8.0	10	37	19	50	TRCG32M16000
TRCG12M16119	TRCG12M16115	M16	5.0 - 10.0	10	39	22	50	TRCG32M16000
TRCG12M20139	TRCG12M20135	M20	7.0 - 12.0	10	40	24	50	TRCG32M20000
TRCG12M20169	TRCG12M20165	M20	10.0 - 14.0	10	43	27	50	TRCG32M20000
TRCG12M25169	TRCG12M25165	M25	10.0 - 14.0	10	45	27	50	TRCG32M25000
TRCG12M25219	TRCG12M25215	M25	12.0 - 18.0	10	49	33	20	TRCG32M25000
TRCG12M32009	TRCG12M32005	M32	16.0 - 25.0	10	52	42	20	TRCG32M32000
TRCG12M40009	TRCG12M40005	M40	22.0 - 32.0	10	62	53	10	TRCG32M40009
TRCG12M50009	TRCG12M50005	M50	28.0 - 38.5	12	67	60	5	TRCG32M50009
TRCG12M63009	TRCG12M63005	M63	40.0 - 48.0	12	68	70	5	TRCG32M63009

H = SW = Key size tool

Dimensions (mm)

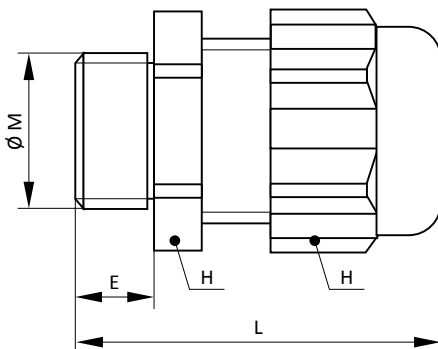



Polyamide plugs with metric threads for use with increased safety Ex e enclosure.

TECHNICAL DATA

Material	Polyamide
IP rating	IP68
Temperature range	-35°C to +90°C
Certificate	LCIE 03ATEX0033U
Marking	Ex e
Gasket	Included
Threads	Metric - PG and NPT on request
Accessories	Lock nut, Gasket

Product code (Colour black)	Thread Ø M	E	L	H	Packing Pieces	Lock nut to order separately
TRCG22M16009	M16	8	12.0	20	50	TRCG32M16000
TRCG22M20009	M20	9	13.0	26	50	TRCG32M20000
TRCG22M25009	M25	10	15.0	32	25	TRCG32M25000
TRCG22M32009	M32	11	16.5	40	15	TRCG32M32000
TRCG22M40009	M40	12	18.0	48	10	TRCG32M40009
TRCG22M50009	M50	13	21.0	55	10	TRCG32M50009
TRCG22M63009	M63	15	24.5	70	10	TRCG32M63009

H = SW = Key size tool

Dimensions

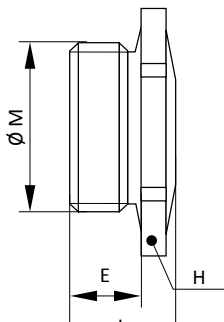



Nickel-plated brass cable glands with metric threads for use with increased safety Ex e enclosure.

TECHNICAL DATA

Material	Nickel-plated brass
IP rating	IP68
Temperature range	-40°C ... +100°C
Certificate	LCIE 03ATEX6400X
Marking	Ex e
Gasket	Included
Threads	Metric - PG and NPT on request
Accessories	Lock nut, Gasket

Product code	Thread Ø M	Clamping range	E	L	H	Packing
TRCG12M12000	M12	4.5 - 6.5	5	25	14	50
TRCG12M16000	M16	5 - 9,5	5	28	17	50
TRCG12M20000	M20	8 - 13	6	32	22	50
TRCG12M22000	M25	9 - 16	7	35	27	20
TRCG12M32000	M32	12 - 21	8	38	34	20
TRCG12M40000	M40	16 - 27	8	41	42	20
TRCG12M50000	M50	23 - 35	9	46	55	10
TRCG12M63000	M63	36 - 48	10	54	65	5

H = SW = Key size tool

Dimensions

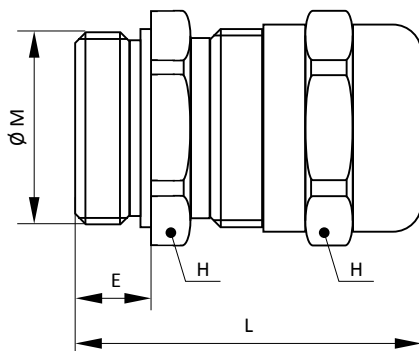

Plugs

Increased safety Nickel-plated brass - TRCG series



Nickel-plated brass plugs with metric threads for use with increased safety Ex e enclosure.

TECHNICAL DATA

Material	Nickel-plated brass
IP rating	IP68
Temperature range	-20°C to +80°C
Certificate	LCIE 03ATEX0033U
Marking	Ex e
Gasket	Included
Threads	Metric - PG and NPT on request
Accessories	Lock nut, Gasket

Product code	Thread Ø M	E	L	H	Packing Pieces	Lock nut to order separately
TRCG22M16009NP	M16	8	12.0	20	50	TRCG32M16000NP
TRCG22M20009NP	M20	9	13.0	26	50	TRCG32M20000NP
TRCG22M25009NP	M25	10	15.0	32	25	TRCG32M25000NP
TRCG22M32009NP	M32	11	16.5	40	15	TRCG32M32000NP
TRCG22M40009NP	M40	12	18.0	48	10	TRCG32M40009NP
TRCG22M50009NP	M50	13	21.0	55	10	TRCG32M50009NP
TRCG22M63009NP	M63	15	24.5	70	10	TRCG32M63009NP

H = SW = Key size tool

Dimensions

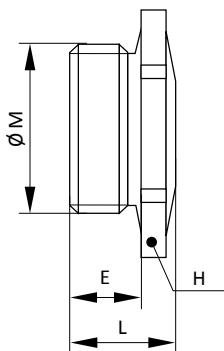





Audible and Visual Signalling devices

Content	Page
Beacons / Lights	
BC125 and BC150 series	136
Sounders / Horns	
SD125-1 and SD150-1 series	140
Sounders and beacons	
SB125-1 and SB150-1 series	144
Combined products	
SB125 and SB150 series	148
Status lights	
SL125 and SL150 series	152
Manual call point	
CP125, CP135 and CP150 series	156
Push buttons	
PB125, PB135 and PB150 series	162
Junction boxes	
JB125 and JB150 seires	168
Accessories and spare parts	
	172



This beacon is designed for corrosive environments and dedicated for the Oil & Gas, chemical, petrochemical, pharmacy industries, marine and offshore applications. It is available in two lighting technology options, each with four selectable flashing frequencies:

- LED with steady, rotary, fixed or blinking LED of different powers
- Flashing with XENON tube of different powers

The housing in stainless steel AISI 316L is coated with a UV resistant paint. The lens is made with borosilicate glass.

Optional: control of the beacon via a telephone.

Accessories to customize the products are available (refer to page 172).

TECHNICAL DATA

Material	ENCLOSURE: Stainless steel AISI 316L		LENS: Tempered borosilicate glass 3.3			
Colour	RED: RAL 3001 - YELLOW**: RAL1018 - BLUE**: RAL5005 - BLACK**: RAL9005					
IP rating	IP66/67					
Ambient temperature	-40°C ... +70°C					
Certificates	NEMKO 13ATEX1561X IECEX NEM 13.0030X					
Marking	II 2 GD Ex d IIC T4 ... T6 Gb Ex tb IIIC T135°C ... T85°C					
Lens colour - Candela lens colour factor	Red: 0.15 Amber: 0.51 Blue: 0.12 Green: 0.49 Clear: 1					
Light type	Flash tube (Xenon)		LED			
True light intensity	5 joules = 109 Cd 10 joules = 293 Cd 15 joules = 395 cd 21 joules = 424 Cd		5 W = 128 Cd 10W = 312 Cd			
Peak light intensity	5 joules = 35970 Cd 10 joules = 66804 Cd 15 joules = 83345 Cd 21 joules = 95824 Cd					
Consumption	5 joules = 10W 10 joules = 15W 15 joules = 20W 21 joules = 25W		5W 10W			
Time life	Emissions reduced to 70% after 8 million flashes		>50 000 h without luminosity decreasing			
Blinking or rotary frequency	60/80/120 Times/min 100/120/150 Times/min 120/150/180 Times/min		60/75/0 Times/min (1) 60/75/100 Times/min 75/95/0 Times/min (1) 75/95/120 Times/min (1) (0 = steady status)			
Ambient Humidity*	Until 95%					
Power supply	12 ... 48V DC		12 ... 48V AC (50/60hz)		100 ... 240V AC (50/60hz)	
Rated impulse withstand voltage	1 kV according to IEC 61000-4-5					
LED operating current	Power	12V DC	24V DC	48V DC	110V AC	220V AC
	5W	530 mA	260 mA	120 mA	80 mA	40 mA
	10W	1100 mA	530 mA	240 mA	160 mA	80 mA
XENON operating current	Energy	12V DC	24V DC	48V DC	110V AC	220V AC
	5J	460 mA	280 mA	140 mA	60 mA	35 mA
	10J	850 mA	490 mA	250 mA	100 mA	60 mA
	15J	1200 mA	700 mA	360 mA	140 mA	80 mA
	21J	NA	960 mA	480 mA	180 mA	110 mA
Cable entries	4 x M20, M25**, 1/2" NPT**, 3/4" NPT** or other** (Specify)					
Terminals	From 22 to 14 AWG - From 0.50 mm ² to 2.5 mm ²					
Net weight	4.5 kg					
External trigger**	25Hz <f<50Hz		40V<U<100V		Z = 2k Ohm	

* = without runoff ** = Optional - cable gland and blind plug not provided

Add the codes related to the features required to **BC125** :

Product code configurator									
Lens colour	Type	Power	Voltage	Duty label	Tag label	Lens guard	Cable entry	Finish colour	Telephone initiated
■ R = Red	X = Xenon	05 LED: 5W Xenon: 5J	DC 12 .. 48V DC	Y = Yes	Y = Yes	Y = Yes	A = M20	■ RD = Red	Y = Yes
■ A = Amber		10 LED: 10W Xenon: 10J	AC1 12..48V AC				B = M25	■ YW = Yellow	
■ B = Blue	L = LED	15 Xenon: 15J	AC 100 .. 240V AC	N = No	N = No	N = No	C = 1/2" NPT	■ BU = Blue	N = No
■ G = Green		21 Xenon: 21J	OR (Other Request)				D = 3/4" NPT	■ BL = Black	
■ C = Clear								□ OR = Other on request	

Meaning of lens colour usage in the international standard (IEC 60073)			
Colour	Meaning	Action	Example
■ RED	EMERGENT	Dangerous state Take immediate action	Pressure/Temperature beyond the safe state - Shutdown due to the action of protective devices - Fire alarm - Equipment failure alarm
■ AMBER	ABNORMAL	Abnormal state, near the critical status	Pressure/Temperature above the normal range - Protective device released - Toxic and harmful gases release alarm
■ GREEN	SAFE	Normal state	Pressure/Temperature in normal state - Automatic control system is operating normally
■ BLUE	MANDATORY	Requires operator's action	Emergency evacuation - Abandon rescue and escape - Abandon platform or abandon ship - Enter the command
■ CLEAR	NO SPECIAL SIGNIFICANCE	If uncertainty for other colours, clear is allowed to be used	General information - Can't exactly use red, yellow, green or blue - Used for the implementation of command - Indicate the measured values

Dimensions

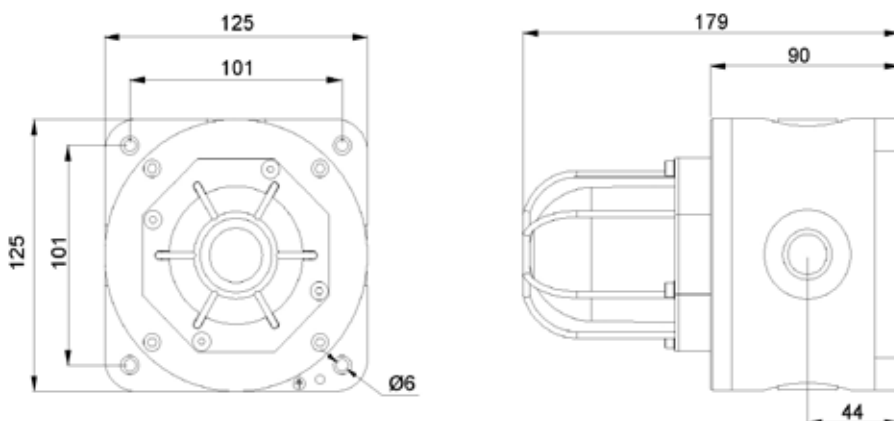



This beacon is designed for corrosive environments and dedicated for the Oil & Gas, chemical, petrochemical, pharmacy industries, marine and offshore applications. It is available in two lighting technology options, each with four selectable flashing frequencies:

- LED with steady, rotary, fixed or blinking LED of different powers
- Flashing with XENON tube of different powers

The housing moulded in glass-reinforced polyester is dyed in the mass and protected with a UV resistant paint. The lens is made with borosilicate glass.

Optionally: control of the beacon via a telephone.

Accessories to customize the products are available (refer to page 172).

TECHNICAL DATA

Material	ENCLOSURE: Glass-reinforced polyester (GRP) LENS: Tempered borosilicate glass 3.3					
Colour	RED: RAL 3001 - YELLOW**: RAL1018 - BLUE**: RAL5005 - BLACK**: RAL9005					
IP rating	IP66/67					
Ambient temperature	-40°C ... +70°C					
Certificates	NEMKO 13ATEX1561X IECEX NEM 13.0030X					
Marking	II 2 GD Ex d IIC T4 ... T6 Gb Ex tb IIIC T135°C ... T85°C					
Lens colour - Candela lens colour factor	Red: 0.15 Amber: 0.51 Blue: 0.12 Green: 0.49 Clear: 1					
Light type	Flash tube (Xenon)		LED			
True light intensity	5 joules = 109 Cd 15 joules = 395 cd	10 joules = 293 Cd 21 joules = 424 Cd	5 W = 128 Cd	10W = 312 Cd		
Peak light intensity	5 joules = 35970 Cd 15 joules = 83345 Cd	10 joules = 66804 Cd 21 joules = 95824 Cd				
Consumption	5 joules = 10W 15 joules = 20W	10 joules = 15W 21 joules = 25W	5W	10W		
Time life	Emissions reduced to 70% after 8 million flashes		>50 000 h without luminosity decreasing			
Blinking or rotary frequency	60/80/120 Times/min 100/120/150 Times/min 120/150/180 Times/min		60/75/0 Times/min (1) 60/75/100 Times/min 75/95/0 Times/min (1) 75/95/120 Times/min (1) (0 = steady status)			
Ambient Humidity*	Until 95%					
Power supply	12 ... 48V DC		12 ... 48V AC (50/60hz)		100 ... 240V AC (50/60hz)	
Rated impulse withstand voltage	1 kV according to IEC 61000-4-5					
LED operating current	Power	12V DC	24V DC	48V DC	110V AC	220V AC
	5W	530 mA	260 mA	120 mA	80 mA	40 mA
	10W	1100 mA	530 mA	240 mA	160 mA	80 mA
XENON operating current	Energy	12V DC	24V DC	48V DC	110V AC	220V AC
	5J	460 mA	280 mA	140 mA	60 mA	35 mA
	10J	850 mA	490 mA	250 mA	100 mA	60 mA
	15J	1200 mA	700 mA	360 mA	140 mA	80 mA
	21J	NA	960 mA	480 mA	180 mA	110 mA
Cable entries	4 x M20, M25**, 1/2" NPT**, 3/4" NPT** or other** (Specify)					
Terminals	From 22 to 14 AWG - From 0.50 mm ² to 2.5 mm ²					
Net weight	3.8 kg					
External trigger**	25Hz <f<50Hz		40V<U<100V		Z = 2k Ohm	
* = without runoff ** = Optional - cable gland and blind plug not provided						

Add the codes related to the features required to **BC150** :

Product code configurator									
Lens colour	Type	Power	Voltage	Duty label	Tag label	Lens guard	Cable entry	Finish colour	Telephone initiated
■ R = Red	X = Xenon	05 LED: 5W Xenon: 5J	DC 12 .. 48V DC	Y = Yes	Y = Yes	Y = Yes	A = M20	■ RD = Red	Y = Yes
■ A = Amber		10 LED: 10W Xenon: 10J	AC1 12..48V AC				B = M25	■ YW = Yellow	
■ B = Blue	L = LED	15 Xenon: 15J	AC 100 .. 240V AC	N = No	N = No	N = No	C = 1/2" NPT	■ BU = Blue	N = No
■ G = Green		21 Xenon: 21J	OR (Other Request)				D = 3/4" NPT	■ BL = Black	
■ C = Clear								□ OR = Other on request	

Meaning of lens colour usage in the international standard (IEC 60073)			
Colour	Meaning	Action	Example
■ RED	EMERGENT	Dangerous state Take immediate action	Pressure/Temperature beyond the safe state - Shutdown due to the action of protective devices - Fire alarm - Equipment failure alarm
■ AMBER	ABNORMAL	Abnormal state, near the critical status	Pressure/Temperature above the normal range - Protective device released - Toxic and harmful gases release alarm
■ GREEN	SAFE	Normal state	Pressure/Temperature in normal state - Automatic control system is operating normally
■ BLUE	MANDATORY	Requires operator's action	Emergency evacuation - Abandon rescue and escape - Abandon platform or abandon ship - Enter the command
■ CLEAR	NO SPECIAL SIGNIFICANCE	If uncertainty for other colours, clear is allowed to be used	General information - Can't exactly use red, yellow, green or blue - Used for the implementation of command - Indicate the measured values

Dimensions

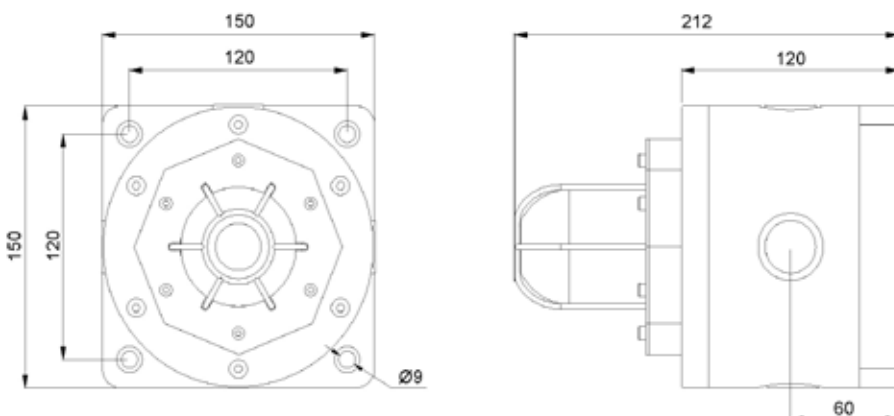



This sounder is designed for corrosive environments and dedicated for the Oil & Gas, chemical, petrochemical, pharmacy industries, marine and offshore applications.

The sounder, according to user control system, can be set with one tone among 59 prerecorded tones.

The housing in stainless steel AISI 316L is coated with a UV resistant paint. Optionally: control of the sounder via a telephone.

Accessories to customize the products are available (refer to page 172).

TECHNICAL DATA

Material	ENCLOSURE & BRACKET: Stainless Steel AISI 316L		
Colour	RED: RAL 3001 - YELLOW**: RAL1018 - BLUE**: RAL5005 - BLACK**: RAL9005		
IP rating	IP66/67		
Ambient temperature	-40°C ... +70°C		
Certificates	NEMKO 13ATEX1562X IECEX NEM 13.0032X		
Marking	II 2 GD Ex d IIC T4 ... T6 Gb Ex tb IIIC T135°C ...T85°C		
Ambient Humidity*	Until 95%		
Power supply	12 ... 48V DC	12 ... 48V AC (50/60hz)	100 ... 240V AC (50/60hz)
Rated impulse withstand voltage	1 kV according to IEC 61000-4-5		
Consumption	Adjustable from 5 to 25 W (factory setting 20W)		
Current consumption	0.5 to 1 A		
Tone selection	59 tones siren. Specific customer tones can be recorded in factory		
Sound output	Until 115 dB at 1 m		
Cable entries	2 x M20, M25**, 1/2" NPT**, 3/4" NPT** or other** (Specify)		
Terminals	From 22 to 14 AWG - From 0.50 mm ² to 2.5 mm ²		
Net weight	6.2 kg		
External trigger**	25Hz <f<50Hz	40V<U<100V	Z = 2k Ohm
* = without runoff ** = optional - cable gland and blind plug not provided			

Add the codes related to the features required to **SD125-1** :

Product code configurator					
Voltage	Duty label	Tag label	Cable entry	Finish colour	Telephone initiated
DC 12 .. 48V DC	Y = Yes	Y = Yes	A = M20	<input type="checkbox"/> RD = Red	Y = Yes
AC1 12..48V AC			B = M25	<input type="checkbox"/> YW = Yellow	
AC 100 .. 240V AC	N = No	N = No	C = 1/2" NPT	<input type="checkbox"/> BU = Blue	N = No
OR (Other Request)			D = 3/4" NPT	<input type="checkbox"/> BL = Black	
				<input type="checkbox"/> OR = Other on request	

Dimensions

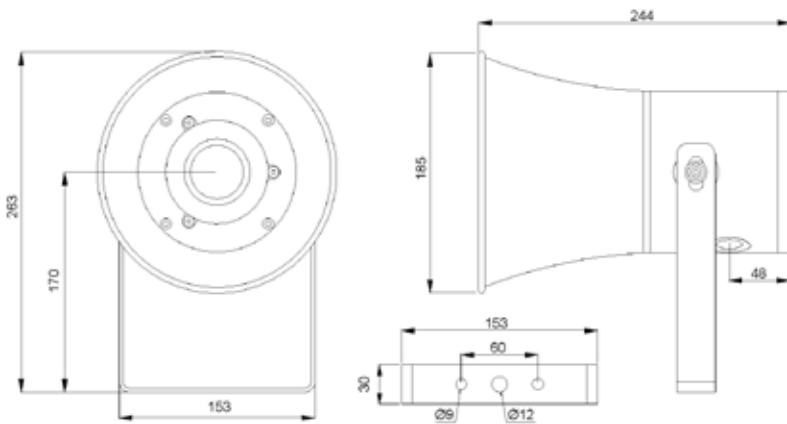



This sounder is designed for corrosive environments and dedicated for the Oil & Gas, chemical, petrochemical, pharmacy industries, marine and offshore applications.

The sounder, according to user control system, can be set with one tone among 59 prerecorded tones.

The housing moulded in glass-reinforced polyester is dyed in the mass and protected with a UV resistant paint. The lens is made with borosilicate glass.

Optionally: control of the sounder via a telephone.

Accessories to customize the products are available (refer to page 172).

TECHNICAL DATA

Material	ENCLOSURE: Glass-reinforced polyester (GRP) BRACKET: Stainless steel AISI 316L		
Colour	RED: RAL 3001 - YELLOW**: RAL1018 - BLUE**: RAL5005 - BLACK**: RAL9005		
IP rating	IP66/67		
Ambient temperature	-40°C ... +70°C		
Certificates	NEMKO 13ATEX1562X IECEX NEM 13.0032X		
Marking	II 2 GD Ex d IIC T4 ... T6 Gb Ex tb IIIC T135°C ...T85°C		
Ambient Humidity*	Until 95%		
Power supply	12 ... 48V DC	12 ... 48V AC (50/60hz)	100 ... 240V AC (50/60hz)
Rated impulse withstand voltage	1 kV according to IEC 61000-4-5		
Consumption	Adjustable from 5 to 25 W (factory setting 20W)		
Current consumption	0.5 to 1 A		
Tone selection	59 tones siren. Specific customer tones can be recorded in factory		
Sound output	Until 115 dB at 1 m		
Cable entries	2 x M20, M25**, 1/2" NPT**, 3/4" NPT** or other** (Specify)		
Terminals	From 22 to 14 AWG - From 0.50 mm ² to 2.5 mm ²		
Net weight	5.4 kg		
External trigger**	25Hz <f<50Hz	40V<U<100V	Z = 2k Ohm
* = without runoff ** = optional - cable gland and blind plug not provided			

Add the codes related to the features required to **SD150-1** :

Product code configurator					
Voltage	Duty label	Tag label	Cable entry	Finish colour	Telephone initiated
DC 12 .. 48V DC	Y = Yes	Y = Yes	A = M20	<input type="checkbox"/> RD = Red	Y = Yes
AC1 12..48V AC			B = M25	<input type="checkbox"/> YW = Yellow	
AC 100 .. 240V AC	N = No	N = No	C = 1/2" NPT	<input type="checkbox"/> BU = Blue	N = No
OR (Other Request)			D = 3/4" NPT	<input type="checkbox"/> BL = Black	
				<input type="checkbox"/> OR = Other on request	

Dimensions

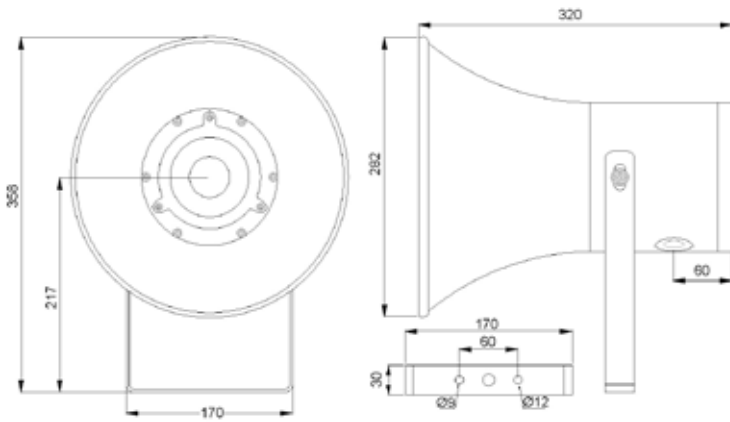



This set with 1 sounder and 1 beacon is designed for corrosive environments and dedicated for all industries including marine and Offshore applications. The beacon is available in two lighting technology options, each with four selectable flashing frequencies:

- LED with steady, rotary, fixed or blinking LED of different powers
- Flashing with xenon tube of different powers

The sounder can be set with one tone among 59 prerecorded tones. The beacon can be triggered either joint or independent.

The housing in stainless steel AISI 316L is coated with a UV resistant paint.

Optionally: control of the beacon or the sounder via a telephone.

Accessories to customize the products are available (refer to page 172).

TECHNICAL DATA

Material	ENCLOSURE & BRACKET: Stainless steel 316L LENS: Tempered borosilicate glass 3.3					
Colour	RED: RAL 3001 - YELLOW**: RAL1018 - BLUE**: RAL5005 - BLACK**: RAL9005					
IP rating	IP66/67					
Ambient temperature	-40°C ... +70°C					
Certificates	NEMKO 13ATEX1566X IECEX NEM 13.0036X					
Marking	II 2 GD Ex d IIC T4 ... T6 Gb Ex tb IIIC T135°C ... T85°C					
Lens colour - Candela lens colour factor	Red: 0.15 Amber: 0.51 Blue: 0.12 Green: 0.49 Clear: 1					
Light type	Flash tube (Xenon)		LED			
True light intensity	5 joules = 109 Cd 15 joules = 395 cd	10 joules = 293 Cd 21 joules = 424 Cd	5 W = 128 Cd	10W = 312 Cd		
Peak light intensity	5 joules = 35970 Cd 15 joules = 83345 Cd	10 joules = 66804 Cd 21 joules = 95824 Cd				
Consumption	5 joules = 10W 15 joules = 20W	10 joules = 15W 21 joules = 25W	5W	10W		
Time life	Emissions reduced to 70% after 8 million flashes		>50 000 h without luminosity decreasing			
Blinking or rotary frequency	60/80/120 Times/min 100/120/150 Times/min 120/150/180 Times/min		60/75/0 Times/min (1) 60/75/100 Times/min 75/95/0 Times/min (1) 75/95/120 Times/min (1) (0 = steady status)			
Ambient Humidity*	Until 95%					
Power supply	12 ... 48V DC		12 ... 48V AC (50/60hz)		100 ... 240V AC (50/60hz)	
Rated impulse withstand voltage	1 kV according to IEC 61000-4-5					
LED operating current	Power	12V DC	24V DC	48V DC	110V AC	220V AC
	5W	530 mA	260 mA	120 mA	80 mA	40 mA
	10W	1100 mA	530 mA	240 mA	160 mA	80 mA
XENON operating current	Energy	12V DC	24V DC	48V DC	110V AC	220V AC
	5J	460 mA	280 mA	140 mA	60 mA	35 mA
	10J	850 mA	490 mA	250 mA	100 mA	60 mA
	15J	1200 mA	700 mA	360 mA	140 mA	80 mA
	21J	NA	960 mA	480 mA	180 mA	110 mA
Tone selection	59 tones siren. Specific customer tones can be recorded in factory					
Sound output	Until 115dB at 1m					
Cable entries	2 x M20, M25**, 1/2" NPT**, 3/4" NPT** or other** (Specify)					
Terminals	From 22 to 14 AWG - From 0.50 mm ² to 2.5 mm ²					
Net weight	8.0 kg					
External trigger**	25Hz <f<50Hz		40V<U<100V		Z = 2k Ohm	

* = without runoff ** = Optional - cable gland and blind plug not provided

Add the codes related to the features required to **SB125-1** :

Product code configurator									
Lens colour	Type	Power	Voltage	Duty label	Tag label	Lens guard	Cable entry	Finish colour	Telephone initiated
■ R = Red	X = Xenon	05 LED: 5W Xenon: 5J	DC 12 .. 48V DC	Y = Yes	Y = Yes	Y = Yes	A = M20	■ RD = Red	Y = Yes
■ A = Amber		10 LED: 10W Xenon: 10J	AC1 12..48V AC				B = M25	■ YW = Yellow	
■ B = Blue	L = LED	15 Xenon: 15J	AC 100 .. 240V AC	N = No	N = No	N = No	C = 1/2" NPT	■ BU = Blue	N = No
■ G = Green		21 Xenon: 21J	OR (Other Request)				D = 3/4" NPT	■ BL = Black	
■ C = Clear								□ OR = Other on request	

Meaning of lens colour usage in the international standard (IEC 60073)			
Colour	Meaning	Action	Example
■ RED	EMERGENT	Dangerous state Take immediate action	Pressure/Temperature beyond the safe state - Shutdown due to the action of protective devices - Fire alarm - Equipment failure alarm
■ AMBER	ABNORMAL	Abnormal state, near the critical status	Pressure/Temperature above the normal range - Protective device released - Toxic and harmful gases release alarm
■ GREEN	SAFE	Normal state	Pressure/Temperature in normal state - Automatic control system is operating normally
■ BLUE	MANDATORY	Requires operator's action	Emergency evacuation - Abandon rescue and escape - Abandon platform or abandon ship - Enter the command
■ CLEAR	NO SPECIAL SIGNIFICANCE	If uncertainty for other colours, clear is allowed to be used	General information - Can't exactly use red, yellow, green or blue - Used for the implementation of command - Indicate the measured values

Dimensions

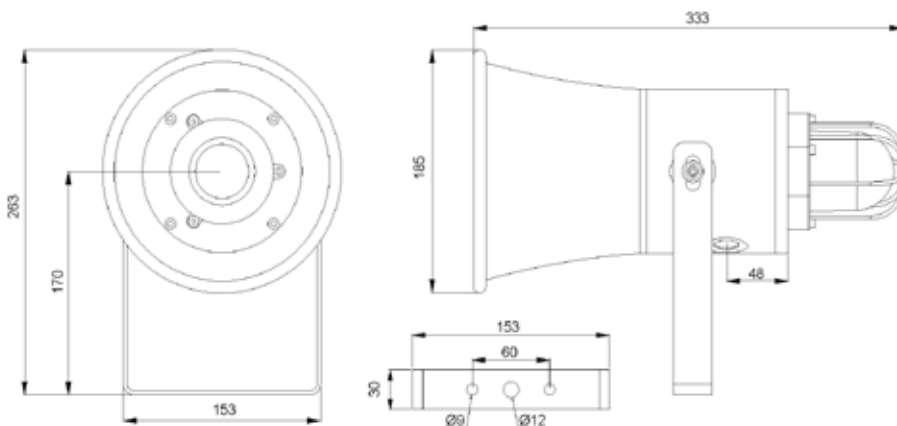



This set with 1 sounder and 1 beacon is designed for corrosive environments and dedicated for all industries including marine and Offshore applications. The beacon is available in two lighting technology options, each with four selectable flashing frequencies:

- LED with steady, rotary, fixed or blinking LED of different powers
- Flashing with xenon tube of different powers

The sounder can be set with one tone among 59 prerecorded tones. The beacon can be triggered either joint or independent.

The housing moulded in glass-reinforced polyester is dyed in the mass and protected with a UV resistant paint.

Optionally: control of the beacon or the sounder via a telephone.

Accessories to customize the products are available (refer to page 172).

TECHNICAL DATA

Material	ENCLOSURE: Glass-reinforced polyester (GRP) LENS: Tempered borosilicate glass 3.3 BRACKET: Stainless steel AISI 316L				
Colour	RED: RAL 3001 - YELLOW**: RAL1018 - BLUE**: RAL5005 - BLACK**: RAL9005				
IP rating	IP66/67				
Ambient temperature	-40°C ... +70°C				
Certificates	NEMKO 13ATEX1566X IECEX NEM 13.0036X				
Marking	II 2 GD Ex d IIC T4 ... T6 Gb Ex tb IIIC T135°C ... T85°C				
Lens colour - Candela lens colour factor	Red: 0.15 Amber: 0.51 Blue: 0.12 Green: 0.49 Clear: 1				
Light type	Flash tube (Xenon)		LED		
True light intensity	5 joules = 109 Cd 10 joules = 293 Cd 15 joules = 395 cd 21 joules = 424 Cd		5 W = 128 Cd 10W = 312 Cd		
Peak light intensity	5 joules = 35970 Cd 10 joules = 66804 Cd 15 joules = 83345 Cd 21 joules = 95824 Cd				
Consumption	5 joules = 10W 10 joules = 15W 15 joules = 20W 21 joules = 25W		5W 10W		
Time life	Emissions reduced to 70% after 8 million flashes		>50 000 h without luminosity decreasing		
Blinking or rotary frequency	60/80/120 Times/min 100/120/150 Times/min 120/150/180 Times/min		60/75/0 Times/min (1) 60/75/100 Times/min 75/95/0 Times/min (1) 75/95/120 Times/min (1) (0 = steady status)		
Ambient Humidity*	Until 95%				
Power supply	12 ... 48V DC		12 ... 48V AC (50/60hz)		100 ... 240V AC (50/60hz)
Rated impulse withstand voltage	1 kV according to IEC 61000-4-5				
LED operating current	Power	12V DC	24V DC	48V DC	110V AC 220V AC
	5W	530 mA	260 mA	120 mA	80 mA 40 mA
	10W	1100 mA	530 mA	240 mA	160 mA 80 mA
XENON operating current	Energy	12V DC	24V DC	48V DC	110V AC 220V AC
	5J	460 mA	280 mA	140 mA	60 mA 35 mA
	10J	850 mA	490 mA	250 mA	100 mA 60 mA
	15J	1200 mA	700 mA	360 mA	140 mA 80 mA
	21J	NA	960 mA	480 mA	180 mA 110 mA
Tone selection	59 tones siren. Specific customer tones can be recorded in factory				
Sound output	Until 115dB at 1m				
Cable entries	2 x M20, M25**, 1/2" NPT**, 3/4" NPT** or other** (Specify)				
Terminals	From 22 to 14 AWG - From 0.50 mm ² to 2.5 mm ²				
Net weight	6.5 kg				
External trigger**	25Hz <f<50Hz		40V<U<100V		Z = 2k Ohm

* = without runoff ** = Optional - cable gland and blind plug not provided

Add the codes related to the features required to **SB150-1** :

Product code configurator									
Lens colour	Type	Power	Voltage	Duty label	Tag label	Lens guard	Cable entry	Finish colour	Telephone initiated
■ R = Red	X = Xenon	05 LED: 5W Xenon: 5J	DC 12 .. 48V DC	Y = Yes	Y = Yes	Y = Yes	A = M20	■ RD = Red	Y = Yes
■ A = Amber		10 LED: 10W Xenon: 10J	AC1 12..48V AC				B = M25	■ YW = Yellow	
■ B = Blue	L = LED	15 Xenon: 15J	AC 100 .. 240V AC	N = No	N = No	N = No	C = 1/2" NPT	■ BU = Blue	N = No
■ G = Green		21 Xenon: 21J	OR (Other Request)				D = 3/4" NPT	■ BL = Black	
■ C = Clear								□ OR = Other on request	

Meaning of lens colour usage in the international standard (IEC 60073)			
Colour	Meaning	Action	Example
■ RED	EMERGENT	Dangerous state Take immediate action	Pressure/Temperature beyond the safe state - Shutdown due to the action of protective devices - Fire alarm - Equipment failure alarm
■ AMBER	ABNORMAL	Abnormal state, near the critical status	Pressure/Temperature above the normal range - Protective device released - Toxic and harmful gases release alarm
■ GREEN	SAFE	Normal state	Pressure/Temperature in normal state - Automatic control system is operating normally
■ BLUE	MANDATORY	Requires operator's action	Emergency evacuation - Abandon rescue and escape - Abandon platform or abandon ship - Enter the command
■ CLEAR	NO SPECIAL SIGNIFICANCE	If uncertainty for other colours, clear is allowed to be used	General information - Can't exactly use red, yellow, green or blue - Used for the implementation of command - Indicate the measured values

Dimensions

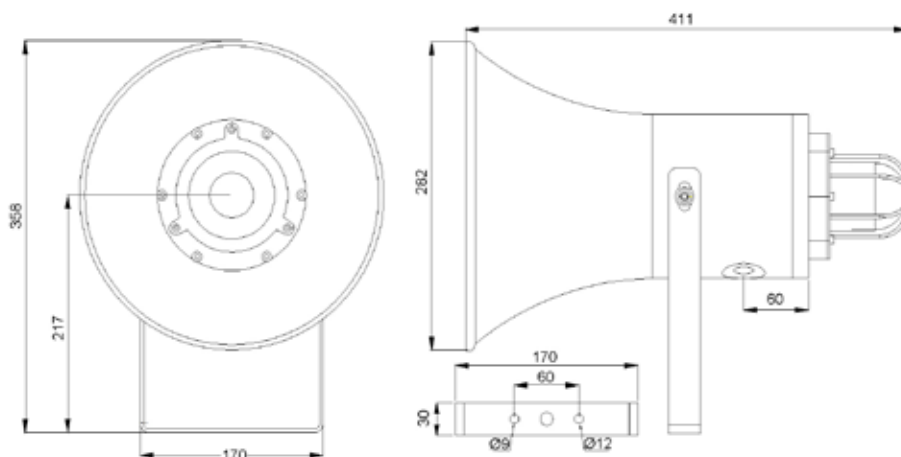



This set is designed for corrosive environments and dedicated for all industries including marine and Offshore applications. The set is provided with a sounder plus a combination of 4 products max. The beacons are available in two lighting technology options, each with four selectable flashing frequencies:

- LED with steady, rotary, fixed or blinking LED of different powers
- Flashing with xenon tube of different powers

The sounder can be set with one tone among 59 prerecorded tones. The beacons can be triggered either joint or independent.

The housing in stainless steel AISI 316L is coated with a UV resistant paint.

Optionally: control of the beacon and the sounder via a telephone. One beacon can be replaced by a push button or a junction box.

Accessories to customize the products are available (refer to page 172).

TECHNICAL DATA

Material	ENCLOSURE: Stainless steel 316L	LENS: Tempered borosilicate glass 3.3
	MOUNTING PLATE: Stainless steel AISI 316L	
Colour	RED: RAL 3001 - YELLOW**: RAL1018 - BLUE**: RAL5005 - BLACK**: RAL9005	
IP rating	IP66/67	
Ambient temperature	-40°C ... +70°C	
Certificates	NEMKO 13ATEX1561X IECEX NEM 13.0030X	
Marking	II 2 GD Ex d IIC T4 ... T6 Gb Ex tb IIIC T135°C ... T85°C	
Lens colour - Candela lens colour factor	Red: 0.15 Amber: 0.51 Blue: 0.12 Green: 0.49 Clear: 1	
Light type	Flash tube (Xenon)	LED
True light intensity	5 joules = 109 Cd 10 joules = 293 Cd 15 joules = 395 cd 21 joules = 424 Cd	5 W = 128 Cd 10W = 312 Cd
Peak light intensity	5 joules = 35970 Cd 10 joules = 66804 Cd 15 joules = 83345 Cd 21 joules = 95824 Cd	
Consumption	5 joules = 10W 10 joules = 15W 15 joules = 20W 21 joules = 25W	5W 10W
Time life	Emissions reduced to 70% after 8 million flashes	>50 000 h without luminosity decreasing
Blinking or rotary frequency	60/80/120 Times/min 100/120/150 Times/min 120/150/180 Times/min	60/75/0 Times/min (1) 60/75/100 Times/min 75/95/0 Times/min (1) 75/95/120 Times/min (1) (0 = steady status)
Ambient Humidity*	Until 95%	
Power supply	12 ... 48V DC	12 ... 48V AC (50/60hz) 100 ... 240V AC (50/60hz)
Rated impulse withstand voltage	1 kV according to IEC 61000-4-5	
LED operating current	Power	12V DC 24V DC 48V DC 110V AC 220V AC
	5W	530 mA 260 mA 120 mA 80 mA 40 mA
	10W	1100 mA 530 mA 240 mA 160 mA 80 mA
XENON operating current	Energy	12V DC 24V DC 48V DC 110V AC 220V AC
	5J	460 mA 280 mA 140 mA 60 mA 35 mA
	10J	850 mA 490 mA 250 mA 100 mA 60 mA
	15J	1200 mA 700 mA 360 mA 140 mA 80 mA
	21J	NA 960 mA 480 mA 180 mA 110 mA
Tone selection	59 tones siren. Specific customer tones can be recorded in factory	
Sound output	Until 115dB at 1m	
Cable entries	3 x M20, M25**, 1/2" NPT**, 3/4" NPT** or other** (Specify)	
Terminals	From 22 to 14 AWG - From 0.50 mm ² to 2.5 mm ²	
Net weight	SB125-2 : 11.9 kg - SB125-3 : 16.7 kg - SB125-4 : 20.7 kg - SB125-5 : 25.10 kg	
External trigger**	25Hz <f<50Hz 40V<U<100V Z = 2k Ohm	

* = without runoff ** = Optional - cable gland and blind plug not provided

Add the codes related to the features required to **SB125**:

Product code configurator											
Combination type	Lens colour	Type	Power	Voltage	Duty label	Tag label	Lens guard	Cable entry	Finish colour	Tel. init.	
2J/P - 1 Sounder, 1 Beacon with Junction Box or Push Button	■ R = Red	X = Xenon	05 LED: 5W Xenon: 5J	DC 12 .. 48V DC	Y = Yes	Y = Yes	Y = Yes	A = M20	■ RD = Red	Y = Yes	
	■ A = Amber		10 LED: 10W Xenon: 10J	AC1 12..48V AC				B = M25	■ YW = Yellow		
3J/P - 1 Sounder, 2 Beacons with Junction Box or Push Button	■ B = Blue	L = LED	15 Xenon: 15J	AC 100 .. 240V AC	N = No	N = No	N = No	C = 1/2" NPT	■ BU = Blue	N = No	
	■ G = Green							D = 3/4" NPT	■ BL = Black		
O - Other combinations	■ C = Clear		21 Xenon: 21J	OR (Other Request)					□ OR = Other on request		

Meaning of lens colour usage in the international standard (IEC 60073)			
Colour	Meaning	Action	Example
■ RED	EMERGENT	Dangerous state Take immediate action	Pressure/Temperature beyond the safe state - Shutdown due to the action of protective devices - Fire alarm - Equipment failure alarm
■ AMBER	ABNORMAL	Abnormal state, near the critical status	Pressure/Temperature above the normal range - Protective device released - Toxic and harmful gases release alarm
■ GREEN	SAFE	Normal state	Pressure/Temperature in normal state - Automatic control system is operating normally
■ BLUE	MANDATORY	Requires operator's action	Emergency evacuation - Abandon rescue and escape - Abandon platform or abandon ship - Enter the command
■ CLEAR	NO SPECIAL SIGNIFICANCE	If uncertainty for other colours, clear is allowed to be used	General information - Can't exactly use red, yellow, green or blue - Used for the implementation of command - Indicate the measured values

Dimensions

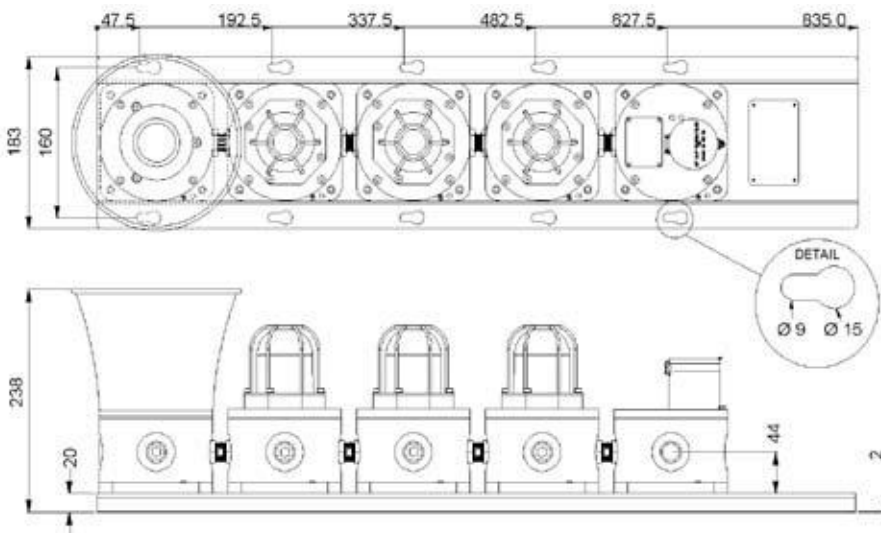



This set is designed for corrosive environments and dedicated for all industries including marine and Offshore applications. The set is provided with a sounder plus a combination of 4 products max. The beacons are available in two lighting technology options, each with four selectable flashing frequencies:

- LED with steady, rotary, fixed or blinking LED of different powers
- Flashing with xenon tube of different powers

The sounder can be set with one tone among 59 prerecorded tones. The beacons can be triggered either joint or independent.

The housing moulded in glass-reinforced polyester is dyed in the mass and protected with a UV resistant paint.

Optionally: control of the beacons and the sounder via a telephone. One beacon can be replaced by a push button or a junction box.

Accessories to customize the products are available (refer to page 172).

TECHNICAL DATA

Material	ENCLOSURE: Glass-reinforced polyester (GRP) LENS: Tempered borosilicate glass 3.3 MOUNTING PLATE: Stainless steel AISI 316L					
Colour	RED: RAL 3001 - YELLOW**: RAL1018 - BLUE**: RAL5005 - BLACK**: RAL9005					
IP rating	IP66/67					
Ambient temperature	-40°C ... +70°C					
Certificates	NEMKO 13 ATEX 1566X IECEX NEM 13.0036X					
Marking	II 2 GD Ex d IIC T4 ... T6 Gb Ex tb IIIC T135°C ... T85°C					
Lens colour - Candela lens colour factor	Red: 0.15 Amber: 0.51 Blue: 0.12 Green: 0.49 Clear: 1					
Light type	Flash tube (Xenon)		LED			
True light intensity	5 joules = 109 Cd 10 joules = 293 Cd 15 joules = 395 cd 21 joules = 424 Cd		5 W = 128 Cd 10W = 312 Cd			
Peak light intensity	5 joules = 35970 Cd 10 joules = 66804 Cd 15 joules = 83345 Cd 21 joules = 95824 Cd					
Consumption	5 joules = 10W 10 joules = 15W 15 joules = 20W 21 joules = 25W		5W 10W			
Time life	Emissions reduced to 70% after 8 million flashes		>50 000 h without luminosity decreasing			
Blinking or rotary frequency	60/80/120 Times/min 100/120/150 Times/min 120/150/180 Times/min		60/75/0 Times/min (1) 60/75/100 Times/min 75/95/0 Times/min (1) 75/95/120 Times/min (1) (0 = steady status)			
Ambient Humidity*	Until 95%					
Power supply	12 ... 48V DC		12 ... 48V AC (50/60hz)		100 ... 240V AC (50/60hz)	
Rated impulse withstand voltage	1 kV according to IEC 61000-4-5					
LED operating current	Power	12V DC	24V DC	48V DC	110V AC	220V AC
	5W	530 mA	260 mA	120 mA	80 mA	40 mA
	10W	1100 mA	530 mA	240 mA	160 mA	80 mA
XENON operating current	Energy	12V DC	24V DC	48V DC	110V AC	220V AC
	5J	460 mA	280 mA	140 mA	60 mA	35 mA
	10J	850 mA	490 mA	250 mA	100 mA	60 mA
	15J	1200 mA	700 mA	360 mA	140 mA	80 mA
	21J	NA	960 mA	480 mA	180 mA	110 mA
Tone selection	59 tones siren. Specific customer tones can be recorded in factory					
Sound output	Until 115dB at 1m					
Cable entries	3 x M20, M25**, 1/2" NPT**, 3/4" NPT** or other** (Specify)					
Terminals	From 22 to 14 AWG - From 0.50 mm ² to 2.5 mm ²					
Net weight	SB150-2 : 10.4 kg - SB150-3 : 14.5 kg - SB150-4 : 18.5 kg - SB150-5 : 22.1 kg					
External trigger**	25Hz <f<50Hz		40V<U<100V		Z = 2k Ohm	

* = without runoff ** = Optional - cable gland and blind plug not provided

Add the codes related to the features required to **SB150**:

Product code configurator											
Combination type	Lens colour	Type	Power	Voltage	Duty label	Tag label	Lens guard	Cable entry	Finish colour	Tel. init.	
2J/P - 1 Sounder, 1 Beacon with Junction Box or Push Button	■ R = Red	X = Xenon	05 LED: 5W Xenon: 5J	DC 12 .. 48V DC	Y = Yes	Y = Yes	Y = Yes	A = M20	■ RD = Red	Y = Yes	
	■ A = Amber		10 LED: 10W Xenon: 10J	AC1 12..48V AC				B = M25	■ YW = Yellow		
3J/P - 1 Sounder, 2 Beacons with Junction Box or Push Button	■ B = Blue	L = LED	15 Xenon: 15J	AC 100 .. 240V AC	N = No	N = No	N = No	C = 1/2" NPT	■ BU = Blue	N = No	
	■ G = Green							D = 3/4" NPT	■ BL = Black		
O - Other Combinations	■ C = Clear		21 Xenon: 21J	OR (Other Request)					□ OR = Other on request		

Meaning of lens colour usage in the international standard (IEC 60073)			
Colour	Meaning	Action	Example
■ RED	EMERGENT	Dangerous state Take immediate action	Pressure/Temperature beyond the safe state - Shutdown due to the action of protective devices - Fire alarm - Equipment failure alarm
■ AMBER	ABNORMAL	Abnormal state, near the critical status	Pressure/Temperature above the normal range - Protective device released - Toxic and harmful gases release alarm
■ GREEN	SAFE	Normal state	Pressure/Temperature in normal state - Automatic control system is operating normally
■ BLUE	MANDATORY	Requires operator's action	Emergency evacuation - Abandon rescue and escape - Abandon platform or abandon ship - Enter the command
■ CLEAR	NO SPECIAL SIGNIFICANCE	If uncertainty for other colours, clear is allowed to be used	General information - Can't exactly use red, yellow, green or blue - Used for the implementation of command - Indicate the measured values

Dimensions

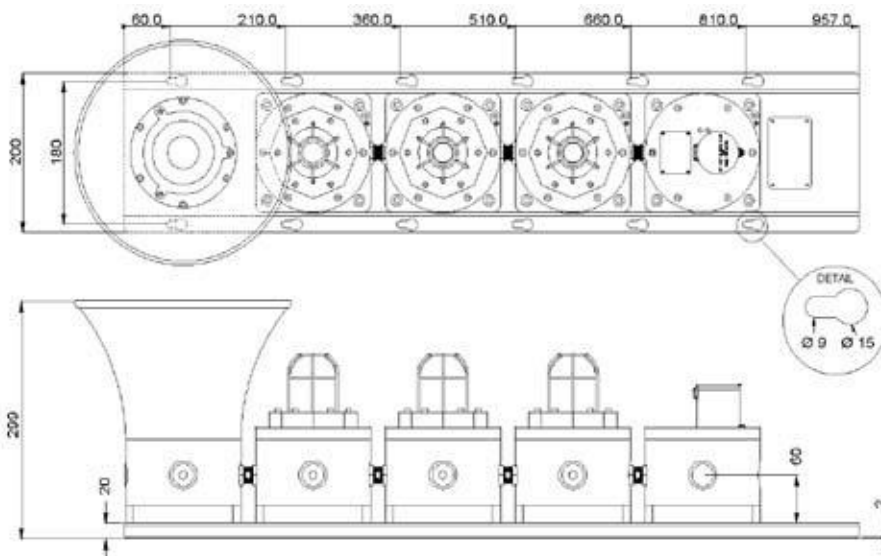



This set is designed for corrosive environments and dedicated for all industries including marine and Offshore applications. The set is provided with a sounder and 4 beacons max. The beacons are available in two lighting technology options, each with four selectable flashing frequencies:

- LED with steady, rotary, fixed or blinking LED of different powers
- Flashing with xenon tube of different powers

The beacons can be triggered either joint or independently.

The housing in stainless steel AISI 316L is coated with a UV resistant paint.

Optionally : control of all beacons or individually via a telephone line. One beacon can be replaced by a push button or a junction box.

Accessories to customize the products are available (refer to page 172).

TECHNICAL DATA

Material	ENCLOSURE: Stainless steel AISI 316L		LENS: Tempered borosilicate glass 3.3			
	MOUNTING PLATE: Stainless steel AISI 316L					
Colour	RED: RAL 3001 - YELLOW**: RAL1018 - BLUE**: RAL5005 - BLACK**: RAL9005					
IP rating	IP66/67					
Ambient temperature	-40°C ... +70°C					
Certificates	NEMKO 13ATEX1565X IECEX NEM 13.0035X					
Marking	II 2 GD Ex d IIC T4 ... T6 Gb Ex tb IIIC T135°C ... T85°C					
Lens colour - Candela lens colour factor	Red: 0.15 Amber: 0.51 Blue: 0.12 Green: 0.49 Clear: 1					
Light type	Flash tube (Xenon)		LED			
True light intensity	5 joules = 109 Cd 10 joules = 293 Cd 15 joules = 395 cd 21 joules = 424 Cd		5 W = 128 Cd 10W = 312 Cd			
Peak light intensity	5 joules = 35970 Cd 10 joules = 66804 Cd 15 joules = 83345 Cd 21 joules = 95824 Cd					
Consumption	5 joules = 10W 10 joules = 15W 15 joules = 20W 21 joules = 25W		5W 10W			
Time life	Emissions reduced to 70% after 8 million flashes		>50 000 h without luminosity decreasing			
Blinking or rotary frequency	60/80/120 Times/min 100/120/150 Times/min 120/150/180 Times/min		60/75/0 Times/min (1) 60/75/100 Times/min 75/95/0 Times/min (1) 75/95/120 Times/min (1) (0 = steady status)			
Ambient Humidity*	Until 95%					
Power supply	12 ... 48V DC		12 ... 48V AC (50/60hz)		100 ... 240V AC (50/60hz)	
Rated impulse withstand voltage	1 kV according to IEC 61000-4-5					
LED operating current	Power	12V DC	24V DC	48V DC	110V AC	220V AC
	5W	530 mA	260 mA	120 mA	80 mA	40 mA
	10W	1100 mA	530 mA	240 mA	160 mA	80 mA
XENON operating current	Energy	12V DC	24V DC	48V DC	110V AC	220V AC
	5J	460 mA	280 mA	140 mA	60 mA	35 mA
	10J	850 mA	490 mA	250 mA	100 mA	60 mA
	15J	1200 mA	700 mA	360 mA	140 mA	80 mA
	21J	NA	960 mA	480 mA	180 mA	110 mA
Cable entries	3 x M20, M25**, 1/2" NPT**, 3/4" NPT** or other** (Specify)					
Terminals	From 22 to 14 AWG - From 0.50 mm ² to 2.5 mm ²					
Net weight	SL125-2: 10.2 kg - SL125-3: 15.0 kg - SL125-4: 20.0 kg - SL125-5: 24.5 kg					
External trigger**	25Hz <f<50Hz		40V<U<100V		Z = 2k Ohm	
	* = without runoff ** = Optional - cable gland and blind plug not provided					

Add the codes related to the features required to **SL125**:

Product code configurator										
Combination type	Lens colour	Type	Power	Voltage	Duty label	Tag label	Lens guard	Cable entry	Finish colour	Tel. init.
A20 - 2 Beacons	■ R = Red	X = Xenon	05 LED: 5W Xenon: 5J	DC 12 .. 48V DC	Y = Yes	Y = Yes	Y = Yes	A = M20	■ RD = Red	Y = Yes
B30 - 3 Beacons								B = M25		
B3J - 2 Beacons & 1 Junction Box	■ A = Amber		10 LED: 10W Xenon: 10J	AC1 12..48V AC				C = 1/2" NPT	■ YW = Yellow	
B3P - 2 Beacons & 1 Push Button										
C40 - 4 Beacons	■ B = Blue	L = LED	15 Xenon: 15J	AC 100 .. 240V AC	N = No	N = No	N = No	D = 3/4" NPT	■ BU = Blue	N = No
C4J - 3 Beacons & 1 Junction Box										
C4P - 3 Beacons & 1 Push Button	■ G = Green		21 Xenon: 21J	OR (Other Request)				■ BL = Black		
D50 - 5 Beacons									■ C = Clear	
D5J - 4 Beacons & 1 Junction Box										
D5P - 4 Beacons & 1 Push Button										

Meaning of lens colour usage in the international standard (IEC 60073)			
Colour	Meaning	Action	Example
■ RED	EMERGENT	Dangerous state Take immediate action	Pressure/Temperature beyond the safe state - Shutdown due to the action of protective devices - Fire alarm - Equipment failure alarm
■ AMBER	ABNORMAL	Abnormal state, near the critical status	Pressure/Temperature above the normal range - Protective device released - Toxic and harmful gases release alarm
■ GREEN	SAFE	Normal state	Pressure/Temperature in normal state - Automatic control system is operating normally
■ BLUE	MANDATORY	Requires operator's action	Emergency evacuation - Abandon rescue and escape - Abandon platform or abandon ship - Enter the command
■ CLEAR	NO SPECIAL SIGNIFICANCE	If uncertainty for other colours, clear is allowed to be used	General information - Can't exactly use red, yellow, green or blue - Used for the implementation of command - Indicate the measured values

Dimensions

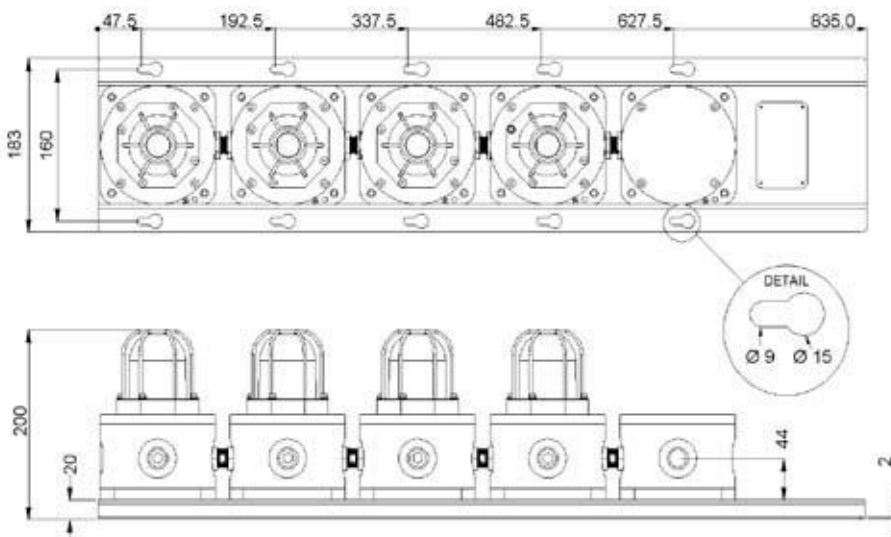



This set is designed for corrosive environments and dedicated for all industries including marine and Offshore applications. The set is provided with a sounder and 4 beacons max. The beacons are available in two lighting technology options, each with four selectable flashing frequencies:

- LED with steady, rotary, fixed or blinking LED of different powers
- Flashing with xenon tube of different powers

The beacons can be triggered either joint or independently.

The housing moulded in glass-reinforced polyester is dyed in the mass and protected with a UV resistant paint.

Optionally : control of all beacons or individually via a telephone line. One beacon can be replaced by a push button or a junction box.

Accessories to customize the products are available (refer to page 172).

TECHNICAL DATA

Material	ENCLOSURE: Glass-reinforced polyester (GRP) LENS: Tempered borosilicate glass 3.3 MOUNTING PLATE: Stainless steel AISI 316L					
Colour	RED: RAL 3001 - YELLOW**: RAL1018 - BLUE**: RAL5005 - BLACK**: RAL9005					
IP rating	IP66/67					
Ambient temperature	-40°C ... +70°C					
Certificates	NEMKO 13ATEX1565X IECEX NEM 13.0035X					
Marking	II 2 GD Ex d IIC T4 ... T6 Gb Ex tb IIIC T135°C ... T85°C					
Lens colour - Candela lens colour factor	Red: 0.15 Amber: 0.51 Blue: 0.12 Green: 0.49 Clear: 1					
Light type	Flash tube (Xenon)		LED			
True light intensity	5 joules = 109 Cd 10 joules = 293 Cd 15 joules = 395 cd 21 joules = 424 Cd		5 W = 128 Cd 10W = 312 Cd			
Peak light intensity	5 joules = 35970 Cd 10 joules = 66804 Cd 15 joules = 83345 Cd 21 joules = 95824 Cd					
Consumption	5 joules = 10W 10 joules = 15W 15 joules = 20W 21 joules = 25W		5W 10W			
Time life	Emissions reduced to 70% after 8 million flashes		>50 000 h without luminosity decreasing			
Blinking or rotary frequency	60/80/120 Times/min 100/120/150 Times/min 120/150/180 Times/min		60/75/0 Times/min (1) 60/75/100 Times/min 75/95/0 Times/min (1) 75/95/120 Times/min (1) (0 = steady status)			
Ambient Humidity*	Until 95%					
Power supply	12 ... 48V DC		12 ... 48V AC (50/60hz)		100 ... 240V AC (50/60hz)	
Rated impulse withstand voltage	1 kV according to IEC 61000-4-5					
LED operating current	Power	12V DC	24V DC	48V DC	110V AC	220V AC
	5W	530 mA	260 mA	120 mA	80 mA	40 mA
	10W	1100 mA	530 mA	240 mA	160 mA	80 mA
XENON operating current	Energy	12V DC	24V DC	48V DC	110V AC	220V AC
	5J	460 mA	280 mA	140 mA	60 mA	35 mA
	10J	850 mA	490 mA	250 mA	100 mA	60 mA
	15J	1200 mA	700 mA	360 mA	140 mA	80 mA
	21J	NA	960 mA	480 mA	180 mA	110 mA
Cable entries	3 x M20, M25**, 1/2" NPT**, 3/4" NPT** or other** (Specify)					
Terminals	From 22 to 14 AWG - From 0.50 mm ² to 2.5 mm ²					
Net weight	SL150-2: 10.2 kg - SL150-3: 15.2 kg - SL150-4: 20.2 kg - SL150-5: 23.9 kg					
External trigger**	25Hz <f<50Hz		40V<U<100V		Z = 2k Ohm	
	* = without runoff ** = Optional - cable gland and blind plug not provided					

Add the codes related to the features required to **SL150**:

Product code configurator										
Combination type	Lens colour	Type	Power	Voltage	Duty label	Tag label	Lens guard	Cable entry	Finish colour	Tel. init.
A20 - 2 Beacons	■ R = Red	X = Xenon	05 LED: 5W Xenon: 5J	DC 12 .. 48V DC	Y = Yes	Y = Yes	Y = Yes	A = M20	■ RD = Red	Y = Yes
B30 - 3 Beacons										
B3J - 2 Beacons & 1 Junction Box	■ A = Amber		10 LED: 10W Xenon: 10J	AC1 12..48V AC				B = M25	■ YW = Yellow	
B3P - 2 Beacons & 1 Push Button										
C40 - 4 Beacons	■ B = Blue	L = LED	15 Xenon: 15J	AC 100 .. 240V AC	N = No	N = No	N = No	C = 1/2" NPT	■ BU = Blue	N = No
C4J - 3 Beacons & 1 Junction Box										
C4P - 3 Beacons & 1 Push Button	■ G = Green		21 Xenon: 21J	OR (Other Request)				D = 3/4" NPT	■ BL = Black	
D50 - 5 Beacons										
D5J - 4 Beacons & 1 Junction Box	■ C = Clear									
D5P - 4 Beacons & 1 Push Button										

Meaning of lens colour usage in the international standard (IEC 60073)			
Colour	Meaning	Action	Example
■ RED	EMERGENT	Dangerous state Take immediate action	Pressure/Temperature beyond the safe state - Shutdown due to the action of protective devices - Fire alarm - Equipment failure alarm
■ AMBER	ABNORMAL	Abnormal state, near the critical status	Pressure/Temperature above the normal range - Protective device released - Toxic and harmful gases release alarm
■ GREEN	SAFE	Normal state	Pressure/Temperature in normal state - Automatic control system is operating normally
■ BLUE	MANDATORY	Requires operator's action	Emergency evacuation - Abandon rescue and escape - Abandon platform or abandon ship - Enter the command
■ CLEAR	NO SPECIAL SIGNIFICANCE	If uncertainty for other colours, clear is allowed to be used	General information - Can't exactly use red, yellow, green or blue - Used for the implementation of command - Indicate the measured values

Dimensions

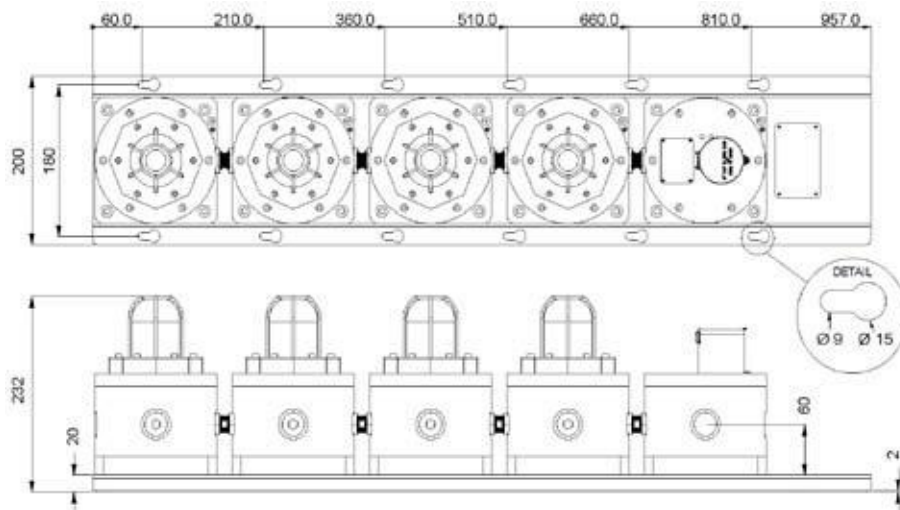



This manual call point “break glass” type is designed for corrosive environments and dedicated for the Oil & Gas, chemical, petrochemical, pharmacy industries, marine and offshore applications.

The product is compatible with PLC, ESD, DCS systems via an output 4-20mA.

The housing in stainless steel AISI 316L is coated with a UV resistant paint.

Optionally: visualisation functions, line detection, glass protection and hammer.

Accessories to customize the products are available (refer to page 172).

TECHNICAL DATA

Material	ENCLOSURE: Stainless steel AISI 316 L
Colour	RED: RAL 3001 - YELLOW**: RAL1018 - BLUE**: RAL5005 - BLACK**: RAL9005
IP rating	IP66/67
Ambient temperature	-40°C ... +70°C
Certificates	NEMKO 13ATEX1563X IECEX NEM 13.0033X
Marking	II 2 GD Ex d IIC T6 Gb Ex tb IIIC T85°C (Tamb = -40°C ... +70°C)
Ambient humidity*	Until 95% with ice*
Rated impulse withstand voltage	1kV according to IEC 61000-4-5
Contact type	1x C/O or 2 x C/O**
Conventional thermal current (Ith)	AC 125/250V (50/60Hz)=11A*** ; 30V DC= 6A*** ; 125V DC = 0.3A***
Minimum voltage and current	DC 5V 10mA
Shorts circuit protection	10 A gG
Cable entries	4 x M20, M25**, 1/2" NPT**, 3/4" NPT** or other** (Specify)
Terminals	From 22 to 14 AWG - From 0.5mm ² to 2.5mm ²
Net Weight	4.9 Kg
Line resistor**	470 Ohm**
Signalling LED**	Green U=24V DC I= 10mA ; Red U=24V DC I= 20mA

* = without runoff - ** = optional - *** = resistive load - cable gland and blind plug not provided

Add the codes related to the features required to **CP125**:

Product code configurator						
Switch	Duty label	Tag label	LED Indicator	Features	Cable entry	Finish colour
Single = 1 x C/O	Y = Yes	Y = Yes	<input type="checkbox"/> <input type="checkbox"/> L = Red & Green	F = Lift Flap	A = M20	<input type="checkbox"/> RD = Red
			<input type="checkbox"/> R = Red	R = Resistor	B = M25	<input type="checkbox"/> YW = Yellow <input type="checkbox"/> BU = Blue
Double = 2 x C/O	N = No	N = No	<input type="checkbox"/> G = Green	D = Diode	C = 1/2" NPT	<input type="checkbox"/> BL = Black
			N = No LED	N = No features	D = 3/4" NPT	<input type="checkbox"/> OR = Other on request

Dimensions

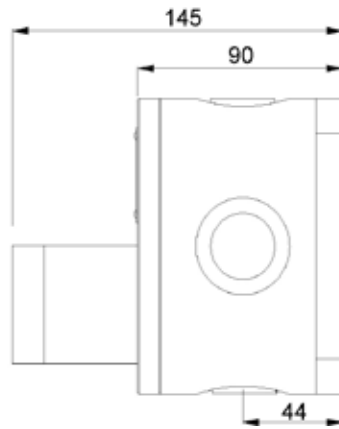
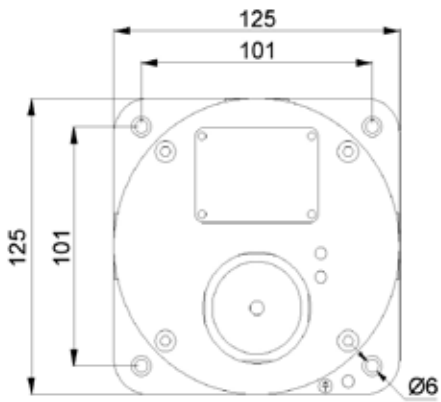



This manual call point “break glass” type is designed for corrosive environments and dedicated for the Oil & Gas, chemical, petrochemical, pharmacy industries, marine and offshore applications.

The product is compatible with PLC, ESD, DCS systems via an output 4-20mA.

The housing moulded in glass-reinforced polyester is dyed in the mass and protected with a UV resistant paint.

Optionally: visualisation functions, line detection, glass protection and hammer.

Accessories to customize the products are available (refer to page 172).

TECHNICAL DATA

Material	ENCLOSURE: Glass-reinforced polyester (GRP)
Colour	RED: RAL 3001 - YELLOW**: RAL1018 - BLUE**: RAL5005 - BLACK**: RAL9005 BLACK WITH YELLOW ZEBRA**
IP rating	IP66/67
Ambient temperature	-40°C ... +70°C
Certificates	NEMKO 13ATEX1568X IECEX NEM 13.0038X
Marking	II 2 GD Ex d IIB+H2 T6 Gb Ex tb IIIC T85°C (Tamb = -40°C ... +70°C)
Ambient humidity*	Until 95% with ice
Rated impulse withstand voltage	1 kV according to IEC 61000-4-5
Contact type	1x C/O or 2 x C/O**
Conventional thermal current (Ith)	AC 125/250V (50/60Hz)=11A*** ; 30V DC= 6A*** ; 125V DC = 0.3A***
Minimum voltage and current	DC 5V 10mA
Shorts circuit protection	10 A gG
Cable entries	2 x M20, M25**, 1/2" NPT**, 3/4" NPT** or other** (Specify)
Terminals	From 22 to 14 AWG - From 0.5mm ² to 2.5mm ²
Net Weight	1.5 kg
Line resistor**	470 Ohm
Signalling LED**	Green U=24V DC I= 10mA ; Red U=24V DC I= 20mA

* = without runoff - ** = optional - *** = resistive load - cable gland and blind plug not provided

Add the codes related to the features required to **CP135**:

Product code configurator							
Switch	Duty label	Tag label	LED Indicator	Features	Cable entry	Entry position	Finish colour
S = Single Switch	Y = Yes	Y = Yes	■ ■ L = Red & Green	F = Lift Flap	A = M20	T = TOP	■ RD = Red
			■ R = Red	R = Resistor	B = M25		■ YW = Yellow
D = Double Switch	N = No	N = No	■ G = Green	D = Diode	C = 1/2" NPT	B = BOTTOM	■ BU = Blue
			N = No LED	N = No features	D = 3/4" NPT		■ BL = Black <input type="checkbox"/> OR = Other on request

Dimensions

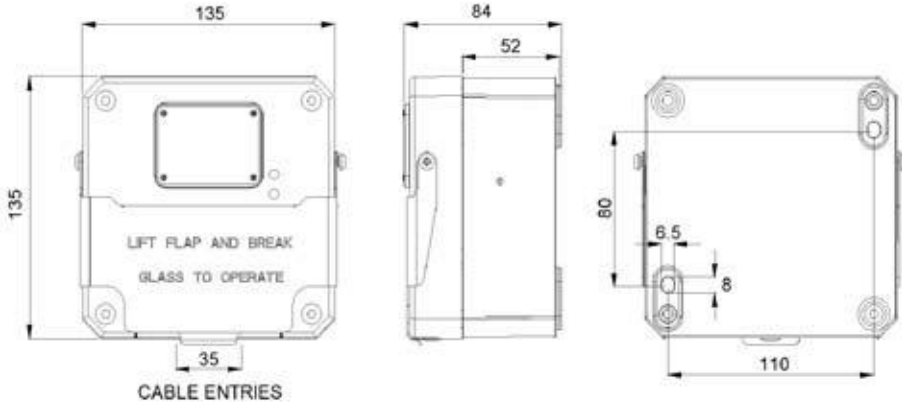



This manual call point “break glass” type is designed for corrosive environments and dedicated for the Oil & Gas, chemical, petrochemical, pharmacy industries, marine and offshore applications.

The product is compatible with PLC, ESD, DCS systems via an output 4-20mA.

The housing moulded in glass-reinforced polyester is dyed in the mass and protected with a UV resistant paint.

Optionally: visualisation functions, line detection, glass protection and hammer.

Accessories to customize the products are available (refer to page 172).

TECHNICAL DATA

Material	ENCLOSURE: Glass-reinforced polyester (GRP)
Colour	RED: RAL 3001 - YELLOW**: RAL1018 - BLUE**: RAL5005 - BLACK**: RAL9005
IP rating	IP66/67
Ambient temperature	-40°C ... +70°C
Certificates	NEMKO 13ATEX1564X IECEX NEM 13.0034X
Marking	II 2 GD Ex d IIC T6 Gb Ex tb IIIC T85°C (Tamb = -40°C ... +70°C)
Ambient humidity*	Until 95% with ice
Rated impulse withstand voltage	1 kV according to IEC 61000-4-5
Contact type	1x C/O or 2 x C/O**
Conventional thermal current (Ith)	AC 125/250V (50/60Hz)=11A*** ; 30V DC= 6A*** ; 125V DC = 0.3A***
Minimum voltage and current	DC 5V 10mA
Shorts circuit protection	10 A gG
Cable entries	4 x M20, M25**, 1/2" NPT**, 3/4" NPT** or other** (Specify)
Terminals	From 22 to 14 AWG - From 0.5mm ² to 2.5mm ²
Net Weight	4.2 kg
Line resistor**	470 Ohm
Signalling LED**	Green U=24V DC I= 10mA ; Red U=24V DC I= 20mA

* = without runoff - ** = optional - *** = resistive load - cable gland and blind plug not provided

Add the codes related to the features required to **CP150**:

Product code configurator							
Switch	Duty label	Tag label		LED Indicator	Features	Cable entry	Finish colour
Single = 1 x C/O	Y = Yes	Y = Yes		■ ■ L = Red & Green	F = Lift Flap	A = M20	■ RD = Red
				■ R = Red	R = Resistor	B = M25	■ YW = Yellow
Double = 2 x C/O	N = No	N = No		■ G = Green	D = Diode	C = 1/2" NPT	■ BU = Blue
				N = No LED	N = No features	D = 3/4" NPT	■ BL = Black <input type="checkbox"/> OR = Other on request

Dimensions

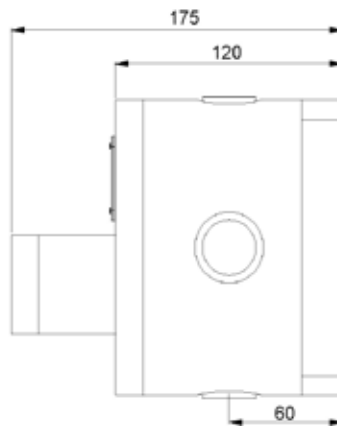
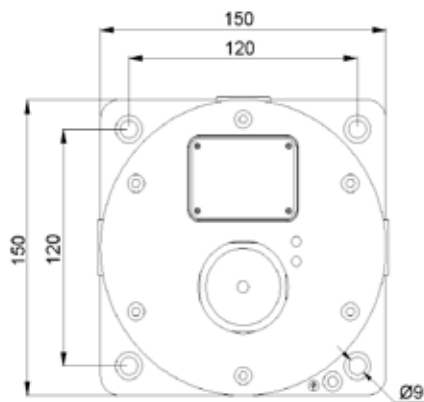



This manual call point “push button” type is designed for corrosive environments and dedicated for the Oil & Gas, chemical, petrochemical, pharmacy industries, marine and offshore applications.

This product is compatible with PLC, ESD, DCS systems via an output 4-20mA.

There are two versions: push button and push button with key to release.

The housing in stainless steel AISI 316L is coated with a UV resistant paint.

Optionally: visualisation functions, line detection and lift flap protection.

Accessories to customize the products are available (refer to page 172).

TECHNICAL DATA

Material	ENCLOSURE: Stainless steel AISI 316L
Colour	RED: RAL 3001 - YELLOW**: RAL1018 - BLUE**: RAL5005 - BLACK**: RAL9005
IP rating	IP66/67
Ambient temperature	-40°C ... +70°C
Certificates	NEMKO 13ATEX1563X IECEX NEM 13.0033X
Marking	II 2 GD Ex d IIC T6 Gb Ex tb IIIC T85°C (Tamb = -40°C ... +70°C)
Ambient humidity*	Until 95%, with ice if flap option
Rated impulse withstand voltage	1 kV according to IEC 61000-4-5
Contact type	1x C/O or 2 x C/O**
Unit type command	Self reset or key to reset
Conventional thermal current (Ith)	AC 125/250V (50/60Hz)=11A*** ; 30V DC= 6A*** ; 125V DC = 0.3A***
Minimum voltage and current	DC 5V 10mA
Shorts circuit protection	10 A gG
Cable entries	4 x M20, M25**, 1/2" NPT**, 3/4" NPT** or other** (Specify)
Terminals	From 22 to 14 AWG - From 0.5mm ² to 2.5mm ²
Net weight	4.9 kg
Line resistor**	470 Ohm
Signalling LED**	Green U=24V DC I= 10mA ; Red U=24V DC I= 20mA

* = without runoff - ** = optional *** = resistive load - cable gland and blind plug not provided

Add the codes related to the features required to **PB125**:

Product code configurator							
Switch	Duty label	Tag label	Reset	LED Indicator	Features	Cable entry	Finish colour
S = Single Switch	Y = Yes	Y = Yes	S = Self Reset	<input type="checkbox"/> <input type="checkbox"/> L = Red & Green	F = Lift Flap	A = M20	<input type="checkbox"/> RD = Red
				<input type="checkbox"/> R = Red	R = Resistor		<input type="checkbox"/> YW = Yellow
D = Double Switch	N = No	N = No	K = Key Reset	<input type="checkbox"/> G = Green	D = Diode	C = 1/2" NPT	<input type="checkbox"/> BU = Blue
				N = No LED	N = No features		<input type="checkbox"/> BL = Black
						D = 3/4" NPT	<input type="checkbox"/> OR = Other on request

Dimensions

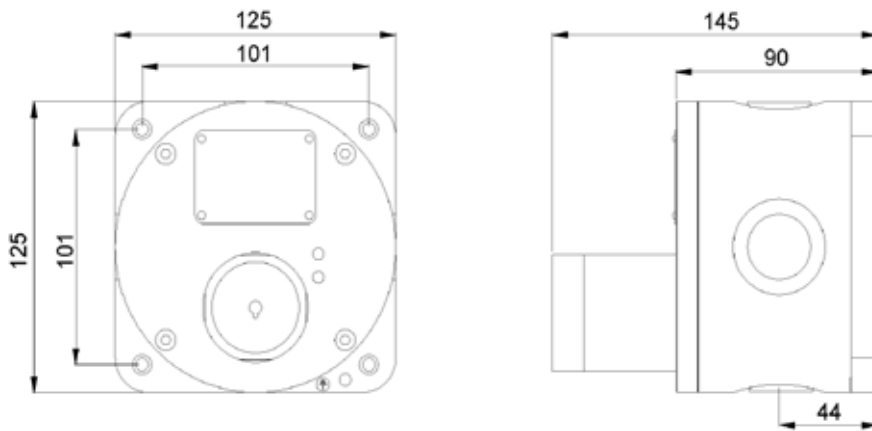

Push buttons

Flameproof - Ex d IIB+H2 - Zones 1 & 2, 21 & 22 Glass-reinforced polyester - PB135 series



This manual call point “push button” type is designed for corrosive environments and dedicated for the Oil & Gas, chemical, petrochemical, pharmacy industries, marine and offshore applications.

This product is compatible with PLC, ESD, DCS systems via an output 4-20mA.

There are two versions: push button and push button with key to release.

The housing moulded in glass-reinforced polyester is dyed in the mass and protected with a UV resistant paint.

Optionally: visualisation functions, line detection and lift flap protection.

Accessories to customize the products are available (refer to page 172).

TECHNICAL DATA

Material	ENCLOSURE: Glass-reinforced polyester (GRP)
Colour	RED: RAL 3001 - YELLOW**: RAL1018 - BLUE**: RAL5005 - BLACK**: RAL9005 BLACK WITH YELLOW ZEBRA**
IP rating	IP66/67
Ambient temperature	-40°C ... +70°C
Certificates	NEMKO 13ATEX1563X IECEX NEM 13.0033X
Marking	II 2 GD Ex d IIB+H2 T6Gb Ex tb IIIC T85°C (Tamb = -40°C ... +70°C)
Ambient humidity*	Until 95%, with ice if flap option
Rated impulse withstand voltage	1kV according to IEC 61000-4-5
Contact type	1x C/O
Unit type command	self reset or key to reset
Conventional thermal current (Ith)	AC 125/250V (50/60Hz)=11A*** ; 30V DC= 6A*** ; 125V DC = 0.3A***
Minimum voltage and current	DC 5V 10mA
Shorts circuit protection	10 A gG
Cable entries	2 x M20, M25**, 1/2" NPT**, 3/4" NPT** or other** (Specify)
Terminals	From 22 to 14 AWG - From 0.5mm ² to 2.5mm ²
Net weight	2.0 kg
Line resistor**	470 Ohm
Signalling LED**	Green U=24V DC I= 10mA ; Red U=24V DC I= 20mA

* = without runoff - ** = optional - *** = resistive load - cable gland and blind plug not provided

Add the codes related to the features required to **PB135** :

Product code configurator								
Switch	Duty label	Tag label	Reset	LED Indicator	Features	Cable entry	Entry position	Finish colour
S = Single Switch	Y = Yes	Y = Yes	S = Self Reset	<input type="checkbox"/> <input type="checkbox"/> L = Red & Green	F = Lift Flap	A = M20	T = TOP	<input type="checkbox"/> RD = Red
				<input type="checkbox"/> R = Red	R = Resistor	B = M25		<input type="checkbox"/> YW = Yellow
	N = No	N = No	K = Key Reset	<input type="checkbox"/> G = Green	D = Diode	C = 1/2" NPT	B = BOTTOM	<input type="checkbox"/> BU = Blue
				N = No LED	N = No features	D = 3/4" NPT		<input type="checkbox"/> BL = Black
								<input type="checkbox"/> OR = Other on request

Dimensions

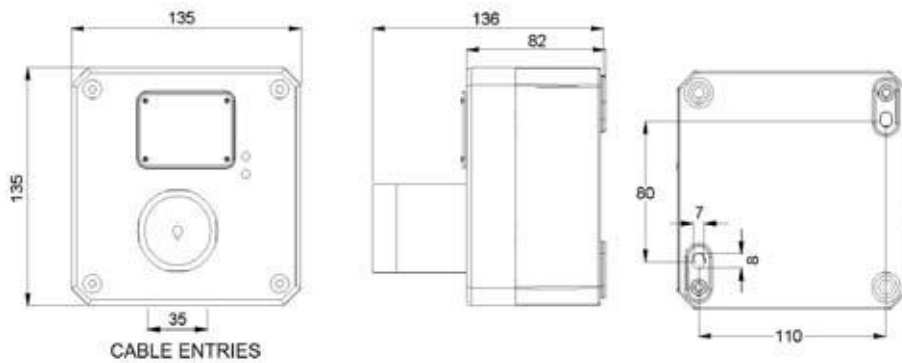



This manual call point “push button” type is designed for corrosive environments and dedicated for the Oil & Gas, chemical, petrochemical, pharmacy industries, marine and offshore applications.

This product is compatible with PLC, ESD, DCS systems via an output 4-20mA.

There are two versions: push button and push button with key to release.

The housing moulded in glass-reinforced polyester is dyed in the mass and protected with a UV resistant paint.

Optionally: visualisation functions, line detection and lift flap protection.

Accessories to customize the products are available (refer to page 172).

TECHNICAL DATA

Material	ENCLOSURE: Glass-reinforced polyester (GRP)
Colour	RED: RAL 3001 - YELLOW**: RAL1018 - BLUE**: RAL5005 - BLACK**: RAL9005
IP rating	IP66/67
Ambient temperature	-40°C to +70°C
Certificates	NEMKO 13ATEX1564X IECEX NEM 13.0034X
Marking	II 2 GD Ex d IIC T6 Gb Ex tb IIIC T85°C (Tamb = -40°C ... +70°C)
Ambient humidity*	Until 95%, with ice if flap option
Rated impulse withstand voltage	1kV according to IEC 61000-4-5
Contact type	1x C/O or 2 x C/O**
Unit type command	self reset or key to reset
Conventional thermal current (Ith)	AC 125/250V (50/60Hz)=11A*** ; 30V DC= 6A*** ; 125V DC = 0.3A***
Minimum voltage and current	DC 5V 10mA
Shorts circuit protection	10 A gG
Cable entries	4 x M20, M25**, 1/2" NPT**, 3/4" NPT** or other** (Specify)
Terminals	From 22 to 14 AWG - From 0.5mm ² to 2.5mm ²
Net weight	4.2 kg
Line resistor**	470 Ohm
Signalling LED**	Green U=24V DC I= 10mA ; Red U=24V DC I= 20mA

* = without runoff - ** = optional- *** = resistive load - cable gland and blind plug not provided

Add the codes related to the features required to **PB150** :

Product code configurator							
Switch	Duty label	Tag label	Reset	LED Indicator	Features	Cable entry	Finish colour
S = Single Switch	Y = Yes	Y = Yes	S = Self Reset	<input type="checkbox"/> <input type="checkbox"/> L = Red & Green	F = Lift Flap	A = M20	<input type="checkbox"/> RD = Red
				<input type="checkbox"/> R = Red	R = Resistor	B = M25	<input type="checkbox"/> YW = Yellow
D = Double Switch	N = No	N = No	K = Key Reset	<input type="checkbox"/> G = Green	D = Diode	C = 1/2" NPT	<input type="checkbox"/> BU = Blue
				N = No LED	N = No features	D = 3/4" NPT	<input type="checkbox"/> BL = Black
							<input type="checkbox"/> OR = Other on request

Dimensions

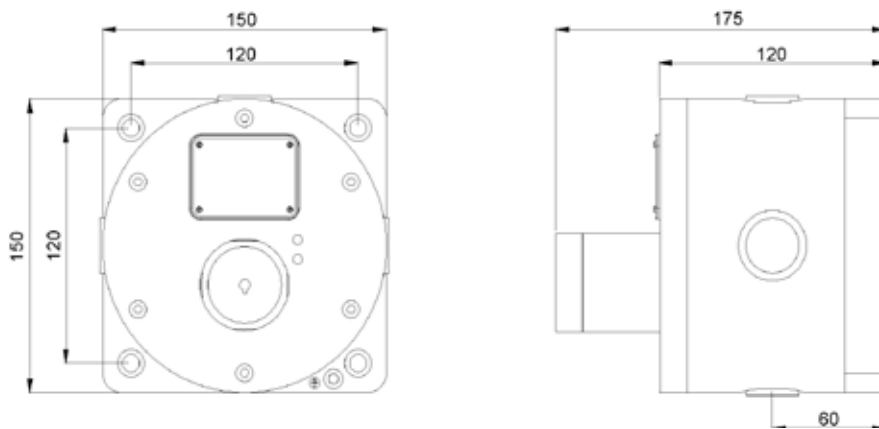



This junction box is designed for corrosive environments and dedicated for the Oil & Gas, chemical, petrochemical, pharmacy industries, marine and offshore applications.

The box is equipped with terminals.

The housing in stainless steel AISI 316L is coated with a UV resistant paint.

Accessories to customize the products are available (refer to page 172).

TECHNICAL DATA

Material	ENCLOSURE: Stainless steel AISI 316L
Colour	RED: RAL 3001 - YELLOW**: RAL1018 - BLUE**: RAL5005 - BLACK**: RAL9005
IP rating	IP66/67
Ambient temperature	-40°C ... +70°C
Certificates	NEMKO 13ATEX1569X IECEX NEM 13.0039X
Marking	II 2 GD Ex d IIC T4 ... T6 Gb Ex tb IIIC T135°C ... T85°C
Ambient humidity*	Until 95%
Cable entries	4 x M20, M25**, 1/2" NPT**, 3/4" NPT** or other** (Specify)
Terminals	8 or 10 terminals for cable from 22 to 14 AWG - from 0.32mm ² to 2.5mm ²
Net weight	4.5 kg
* = without runoff - ** = optional- cable gland and blind plug not provided	

Add the codes related to the features required to **JB125** :

Product code configurator		
Terminal block	Cable entry	Finish colour
00 = Empty	A = M20	<input type="checkbox"/> RD = Red
08 = 8 terminals	B = M25	<input type="checkbox"/> YW = Yellow
10 = 10 terminals	C = 1/2" NPT	<input type="checkbox"/> BU = Blue
	D = 3/4" NPT	<input type="checkbox"/> BL = Black
		<input type="checkbox"/> OR = Other on request

Dimensions

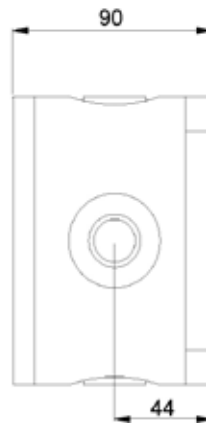
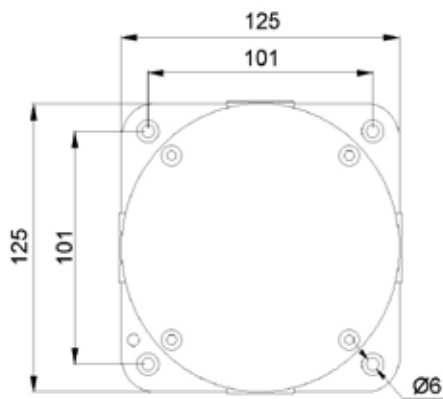



This junction box is designed for corrosive environments and dedicated for the Oil & Gas, chemical, petrochemical, pharmacy industries, marine and offshore applications.

The box is equipped with terminals.

The housing moulded in glass-reinforced polyester is dyed in the mass and protected with a UV resistant paint.

Accessories to customize the products are available (refer to page 172).

TECHNICAL DATA

Material	ENCLOSURE: Glass-reinforced polyester (GRP)
Colour	RED: RAL 3001 - YELLOW**: RAL1018 - BLUE**: RAL5005 - BLACK**: RAL9005
IP rating	IP66/67
Ambient temperature	-40°C ... +70°C
Certificates	NEMKO 13ATEX1569X IECEX NEM 13.0039X
Marking	II 2 GD Ex d IIC T4 ... T6 Gb Ex tb IIIC T135°C ... T85°C,
Ambient humidity*	Until 95%
Cable entries	4 x M20, M25**, 1/2" NPT**, 3/4" NPT** or other** (Specify)
Terminals	8 or 10 terminals for cable from 22 to 14 AWG - from 0.32mm ² to 2.5mm ²
Net weight	2.6 kg
* = without runoff - ** = optional- cable gland and blind plug not provided	







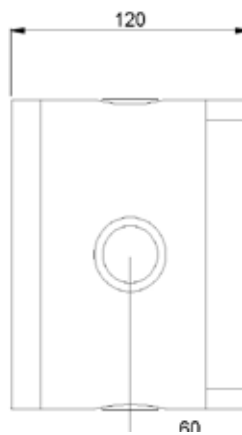
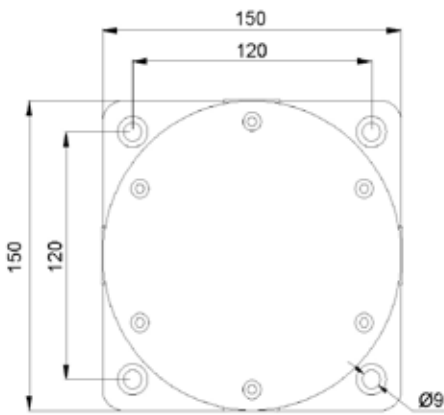

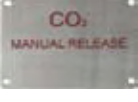

Add the codes related to the features required to **JB150** :

Product code configurator		
Terminal block	Cable entry	Finish colour
00 = Empty	A = M20	<input type="checkbox"/> RD = Red
08 = 8 terminals	B = M25	<input type="checkbox"/> YW = Yellow
10 = 10 terminals	C = 1/2" NPT	<input type="checkbox"/> BU = Blue
	D = 3/4" NPT	<input type="checkbox"/> BL = Black
		<input type="checkbox"/> OR = Other on request

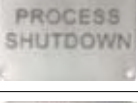











Dimensions

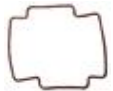

LABELS FOR ALL PRODUCTS - STAINLESS STEEL

Label	Description	Product code
	FIRE	50120110001
	ABANDON PLATFORM	50120110002
	CO2 MANUAL RELEASE	50120110003
	GAS LEAKAGE	50120110004
	MANUAL STATION	5012011005
	PROCESS SHUTDOWN	5012011006
	NORMAL	5012011007
	FIRE / ESD	5012011008
	FIRE HOUSE	5012011009
	TELEPHONE SIGNAL	5012011011
	STAINLESS STEEL TAG LABEL	50080210229

ACCESSORIES AND SPARE PARTS

Picture	Description	Product code	Picture	Description	Product code
	FOR CP125, CP150			FOR PB125, CP125	
	BREAKABLE GLASS (CIRCULAR)	50080270108		HAMMER WITH KEY	50080110205
	FOR CP135			FOR CP135	
	BREAKABLE GLASS (RECTANGULAR)	50080370105		STAINLESS STEEL FLAP	50080310104
	FOR CP135			FOR SD125	
	PLASTIC TEST KEY	50080300230		O RING DIAM 95	50050180237
	FOR SD125			FOR SD150	
	STAINLESS STEEL BRACKET	50050110202-DD		O RING DIAM 115	50050280237
	FOR SD150			FOR CP135	
	STAINLESS STEEL BRACKET	50050250201		HOUSING GASKET	50080380106
	FOR BC125, BC150			FOR PB125, CP125	
	STAINLESS STEEL LENS GUARD FOR BEACON	50060110109		NYLON LIFT FLAP	50080150202
	FOR PB125, CP125			FOR BC125, BC150	
	STAINLESS STEEL CHAIN FOR HAMMER	50080110105		STAINLESS STEEL WALL MOUNTING PLATE 1 SINGLE PRODUCT 2" 2 1/2" 3"	50060110100

